

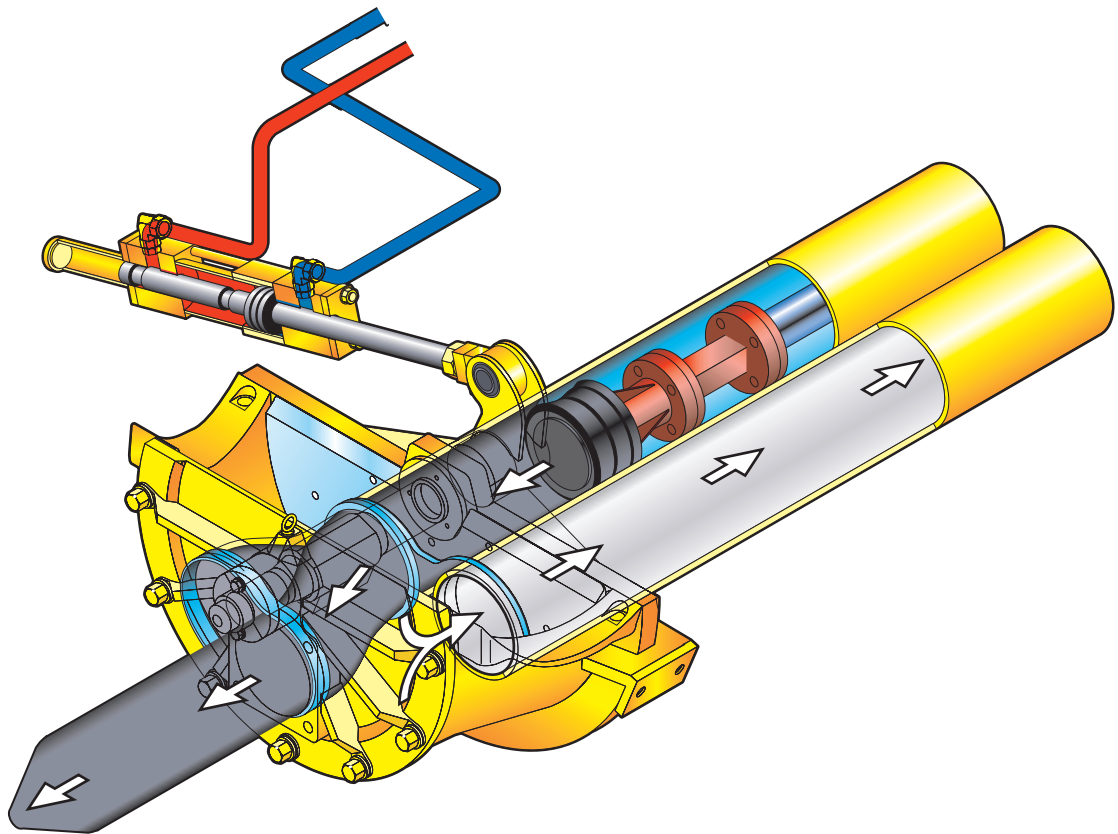

SCHWING
AMERICA INC.

SERVICE REPAIR INSTRUCTIONS FOR
THE "ROCK" VALVE



d

TABLE OF CONTENTS

Safety Instruction	1
Rock Valve Parts Identification - “M” Rock	2
Rock Valve Parts Identification - “E” Rock	3
Rock Valve Parts Identification - “B” Rock	4
Rock Valve Lubrication Points	5
Rotating The Cutting Ring	6
Replacing the Cutting Ring	8
Pressure Spring	10
Tension Nut	10
Determining Wear on Kidney Seal and Kidney Plate	11
Replacing the Kidney Seal	12
Spectacle Plate	16
Replacement of Spectacle Plate	17
Replacement of Outlet Housing Lining (Kidney Plate) Plate	19
Replacement of Outlet Insert (Cover Lining)	21
Rock Valve Body	22
Pivot Shaft	23
Pivot Shaft Bushing	26
Setting Pivot Angles	29
Replacement of Pivot Shaft Bushings	30
Additional Mounting Instructions for E-Rock Assembly	33
Rock Slewing Cylinder	36
Rock Valve with Insert - Conversion	38

TABLE OF CONTENTS

Rock Valve

Safety Instruction

When performing maintenance on Schwing Equipment, the safety regulations must be followed. The observation of these regulations is the responsibility of the maintenance personnel. The following are some supplementary recommendations.



1. **WARNING!** Read and understand the operation manual of the machine before attempting any repairs. If in doubt, call the manufacturer. Incorrectly done repairs endanger operational safety of the machine.
2. **WARNING!** Burning hazard! Never work on a hydraulic system with hot oil.
3. **WARNING!** Falling hazard! If you cannot work at ground level, you must use a suitable work platform.
4. **WARNING!** If maintenance work requires that you use a crane, hoist, fork truck, etc., you must read and understand the safety regulations for that equipment.
5. **WARNING!** If working the machine requires that it be operated, and you are not qualified as an operator, you must get someone who is qualified to assist you.
6. **WARNING!** If you will be working in a hidden area inside the machine, protect yourself by taking the key from the ignition and putting a “DO NOT OPERATE” sign on the controls. In the case of electrically driven units, disconnect the main circuit breaker and lock it in the disconnected position.
7. **WARNING!** Never activate the system hydraulics without checking if another workman is in a hidden position. Always yell “CLEAR”, and allow time for response, before starting the prime mover.
8. **WARNING!** Never use gasoline or diesel fuel as a cleaning solvent. This is critical to remember when cleaning hydraulic oil reservoirs, because gas and diesel fuels are highly explosive, and gasoline or diesel fuel traces left in the oil may ignite when compressed.
9. **WARNING!** Always use the correct tools for the job. Tools should be kept clean, and in good condition.
10. If you see a co-worker engaging in an unsafe practice, explain the dangers. Safety is always in the hands of those on the job.
11. **WARNING!** Never work on a pressurized hydraulic system. Stop the prime mover and relieve the accumulator circuit (if so equipped) before you open the hydraulic system.

Rock Valve Parts Identification - "M" Rock

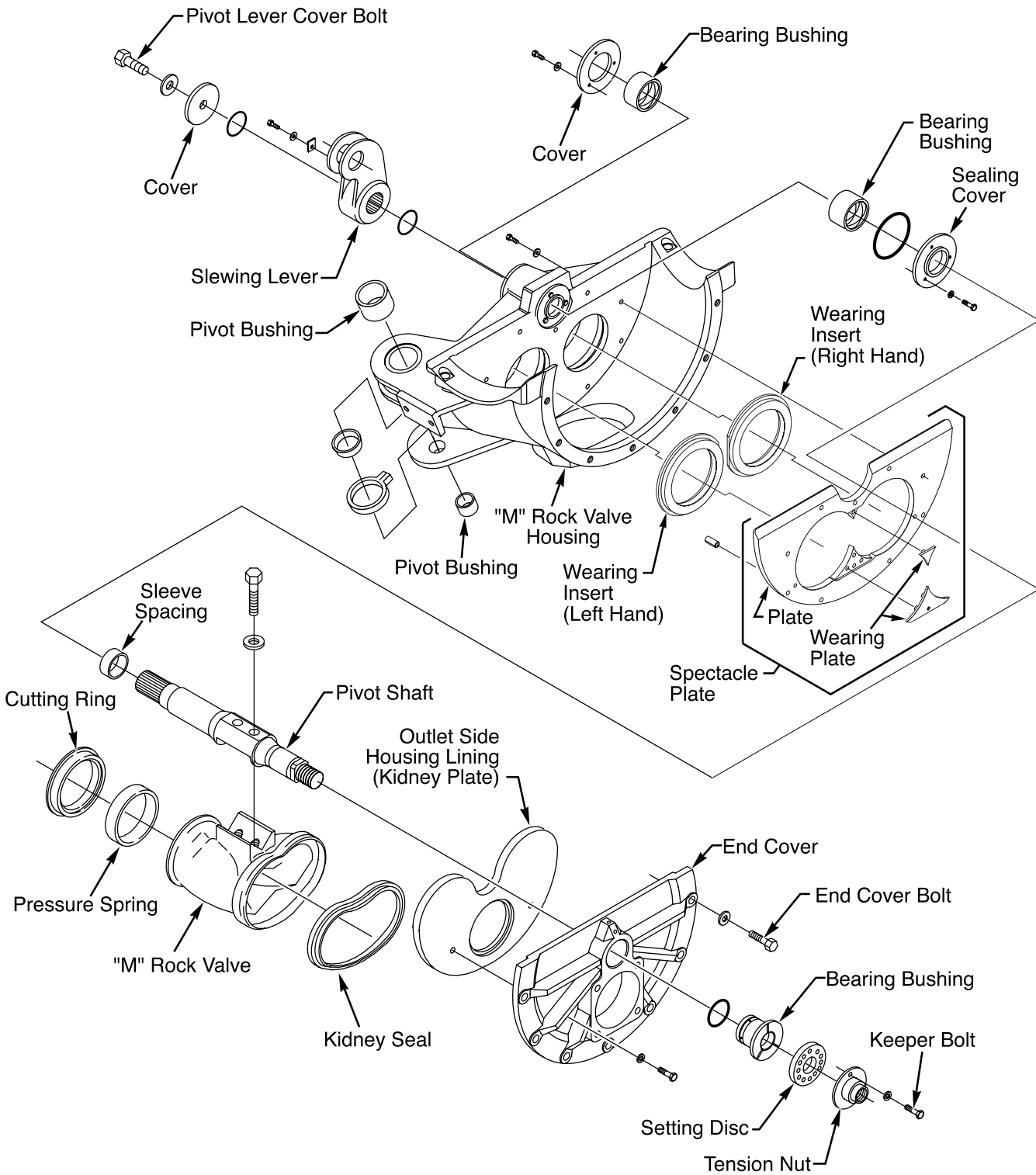

Rock Valve Parts Identification - "E" Rock

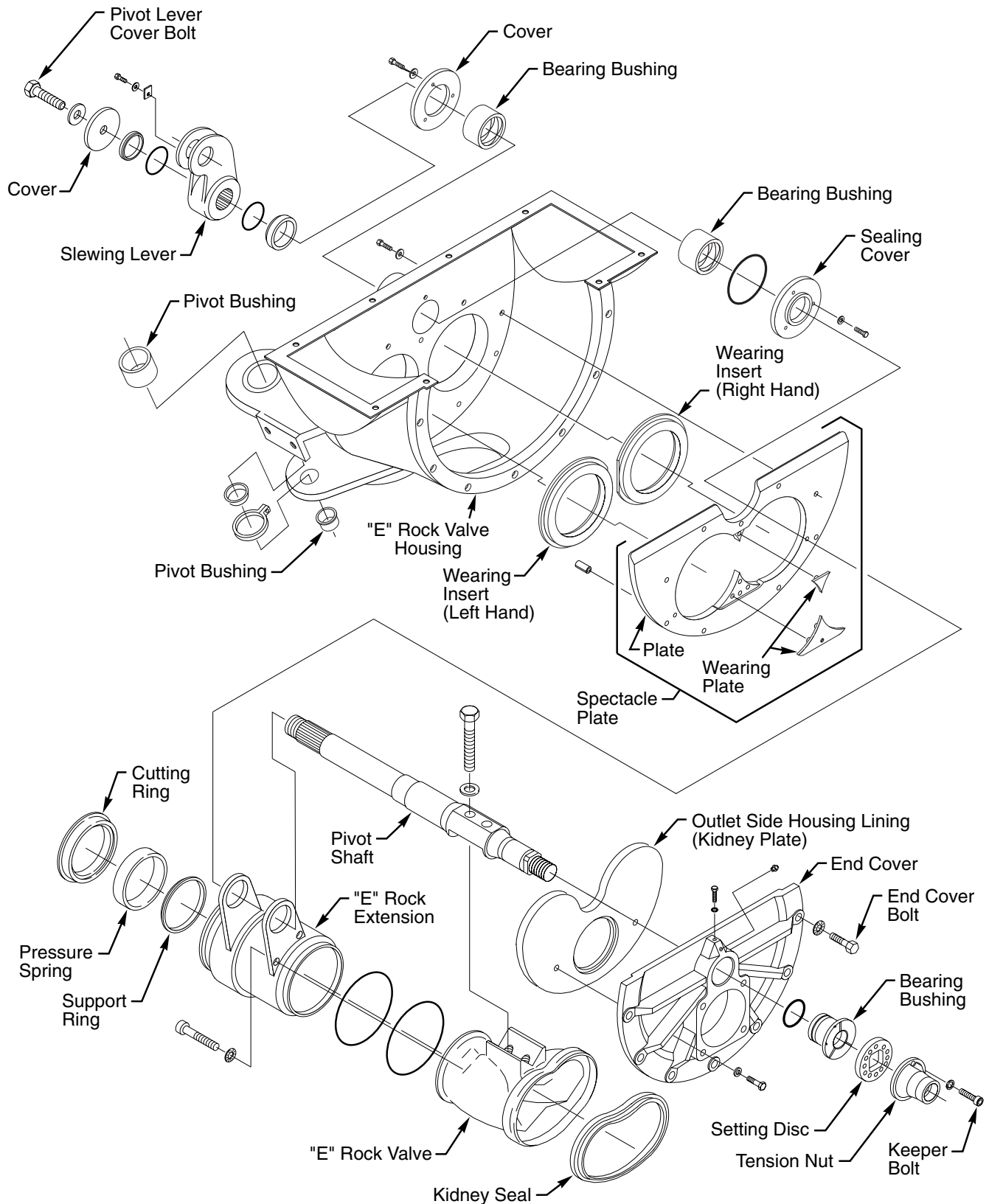

Rock Valve Parts Identification - "B" Rock

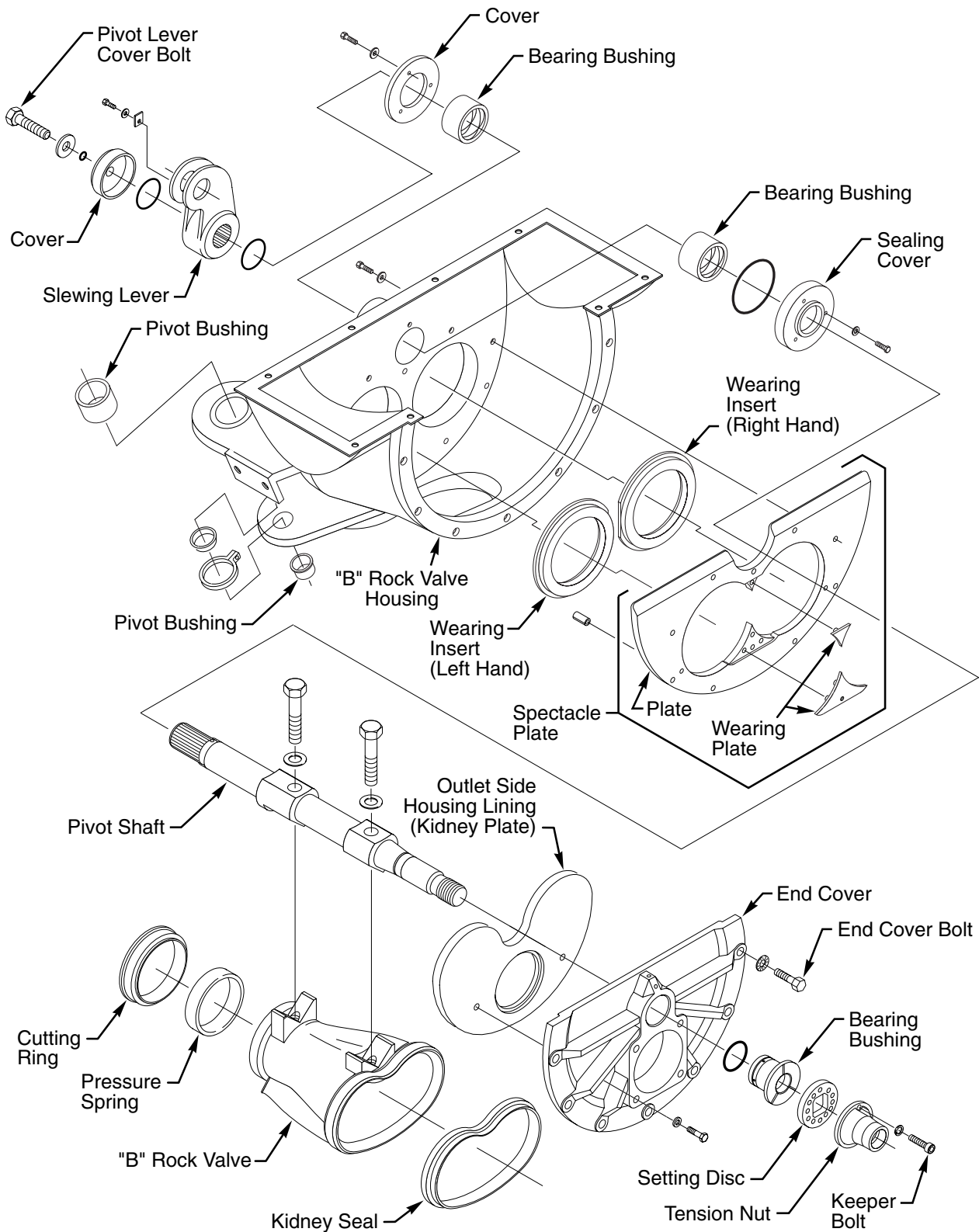

Rock Valve Lubrication Points

If your unit is not equipped with an auto-lube, grease your agitator bearings. There is one zerk on each side of the hopper. Grease every 200 or 300 yards, as the pour allows.

Grease your agitator bearings. There is one zerk on each side of the hopper. Re-grease every two or three hundred yards, as the pour allows.

NOTE! You don't grease agitator bearings like you grease most other bearings. That is, if you normally pump in grease until you see it squirting out somewhere, you will ruin your agitator seals. When you grease the agitator bearings, watch the rubber grease cones that are located inside the hopper. You want the cones to bulge out slightly because they are full of grease, but you don't want to have the grease come out around the shaft, because where the grease comes out concrete will be able to go in. Once concrete makes it inside of the grease cone, you will quickly wear out the bearings. When re-

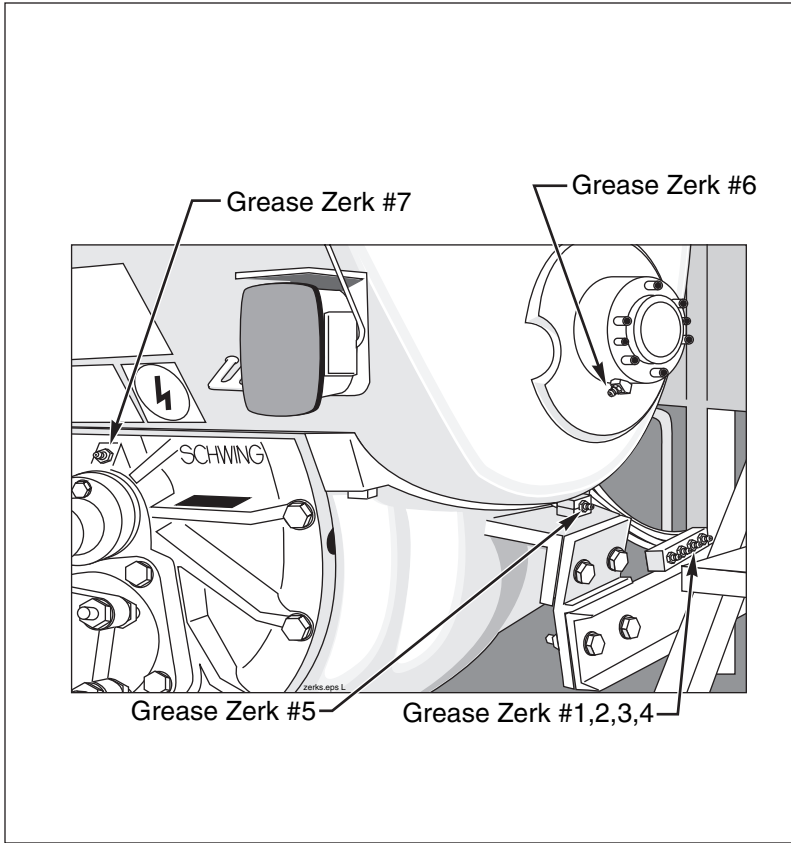

greasing after the hopper is full of concrete and you can no longer see the cones, just give the zerks a couple of squirts. This is one of the few times when it is better to under grease than to over grease.

Grease the rock valve lubrication points before the pour begins. Once you start pumping, grease them every couple of hours. There are six zerks to grease for the rock valve, plus the two for the agitator.

If your unit is equipped with an auto-lube, greasing is accomplished automatically. The grease timers in the cab must be adjusted to assure proper grease flow from each feeder. Check with SAI's Service Department for timer adjustment instructions. The timers are usually mounted on the top of the doghouse between the seats.

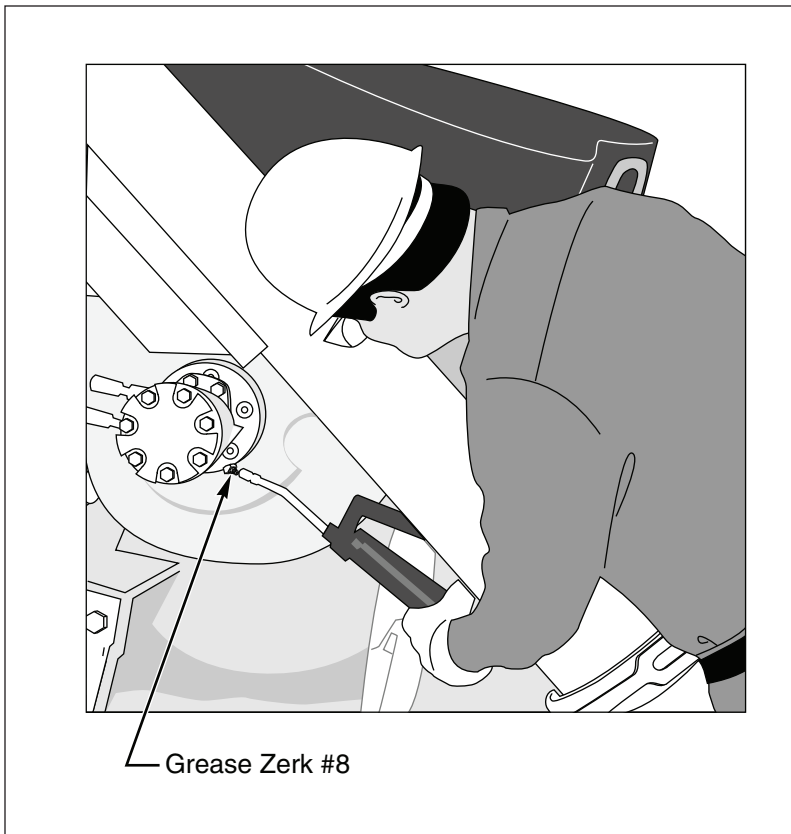

Rock Valve

Rotating The Cutting Ring

1. First, shut off the truck engine and put the key in your pocket.
2. Remove the 6-inch clamp between the tapered bend and the 6-inch elbow.
3. Remove the wedge from the tapered bend, and pull the tapered bend away from the 6-inch clamp.
4. Loosen the tension nut as explained previously.
5. Loosen the seven cover bolts two or three full turns, but do not remove the bolts.
6. Push forward on the end of the rock valve slewing cylinder. Because it has a single pivot point, it will push the rock valve backwards toward the loosened cover. If you meet resistance, do not force it. After you have removed the hopper grate, you can gently pry the rock valve backward from inside the hopper.
7. Remove the hopper grate.

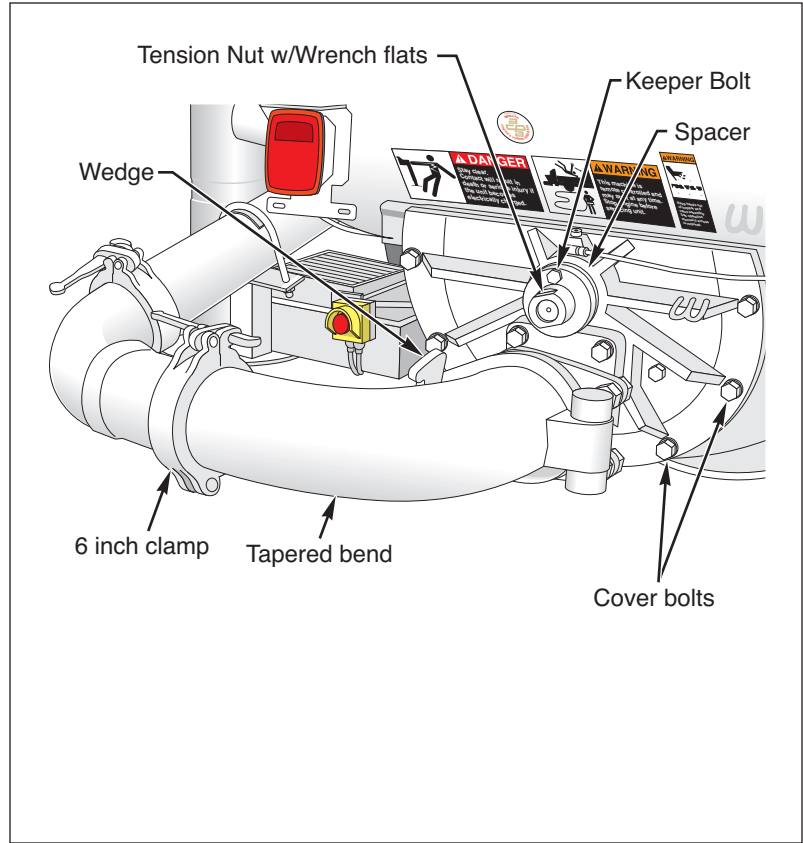

8. From inside the hopper, tap the cutting ring forward, toward the spectacle plate. The ring should pop loose. If it doesn't, loosen the cover bolts a little more, then gently pry the rock valve rearward a little more until it does. Rotate the ring 90° clockwise. (It doesn't really matter which way you rotate, but to keep from forgetting which way you went last time, Schwing recommends going clockwise each time.)
9. Be sure that the ring is centered in the rock valve. Tighten the cover bolts slightly, if needed, to be sure that the ring isn't cocked one way or the other.

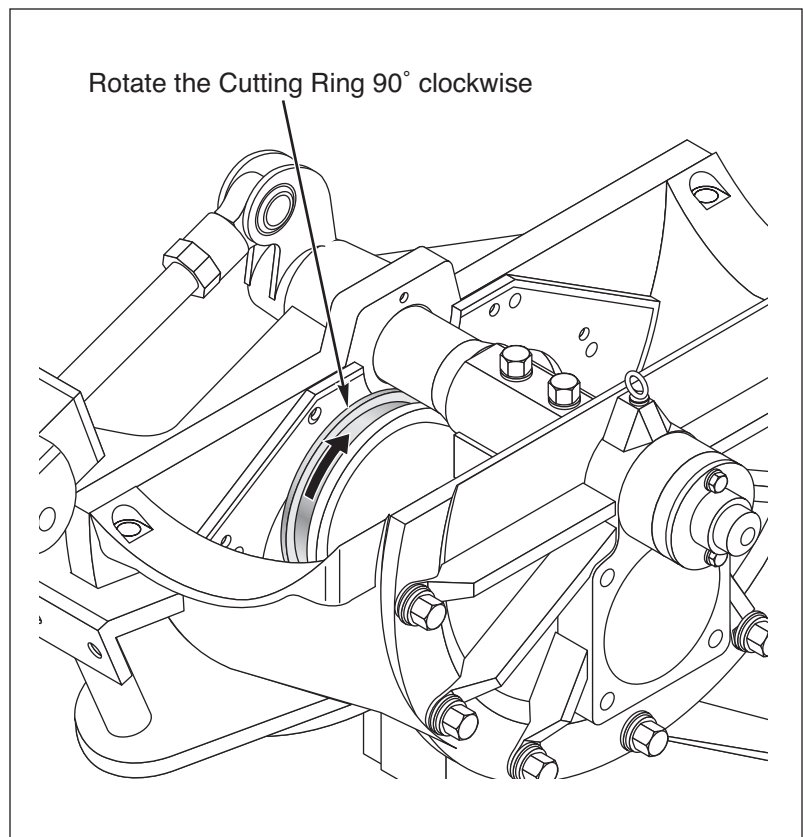

⚠ WARNING

Never rotate the cutting ring without disabling the unit's hydraulic system. Amputation hazard!

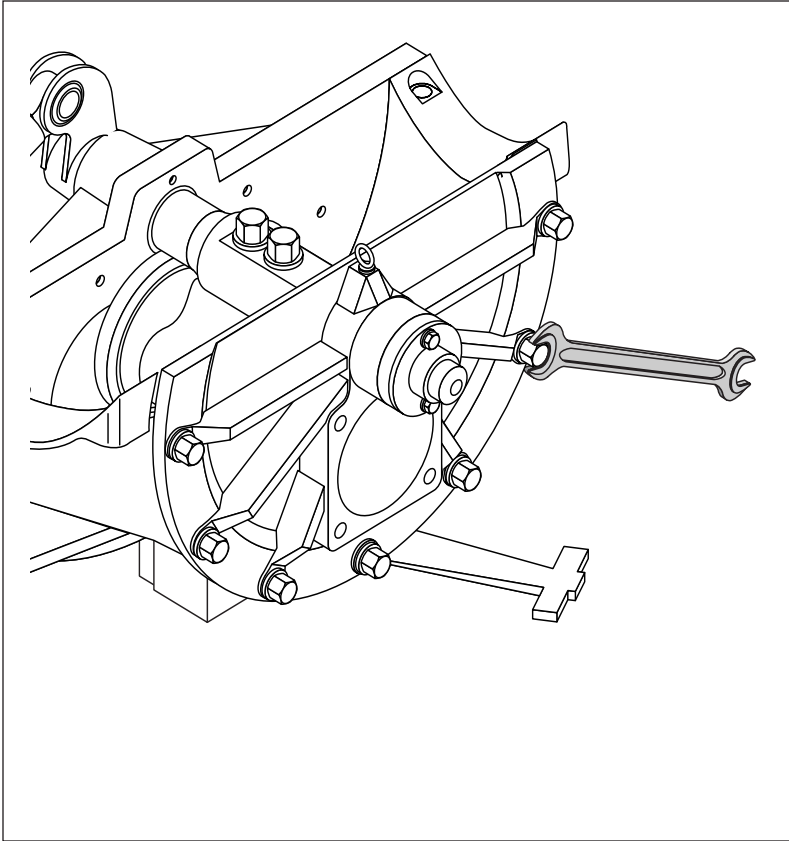

10. Be sure there is no debris between the back cover and the rock valve housing. If there is, clean it out. Tighten the cover bolts just enough to bring the back plate up against the rock housing. Then tighten each bolt equally, using a torque wrench. Alternate which bolts you tighten, as you would when tightening a wheel on a car. The torque specification for these bolts (M24 x 60, 8.8 hardness) is 485 ft./lb. Replace the bolts once per year.

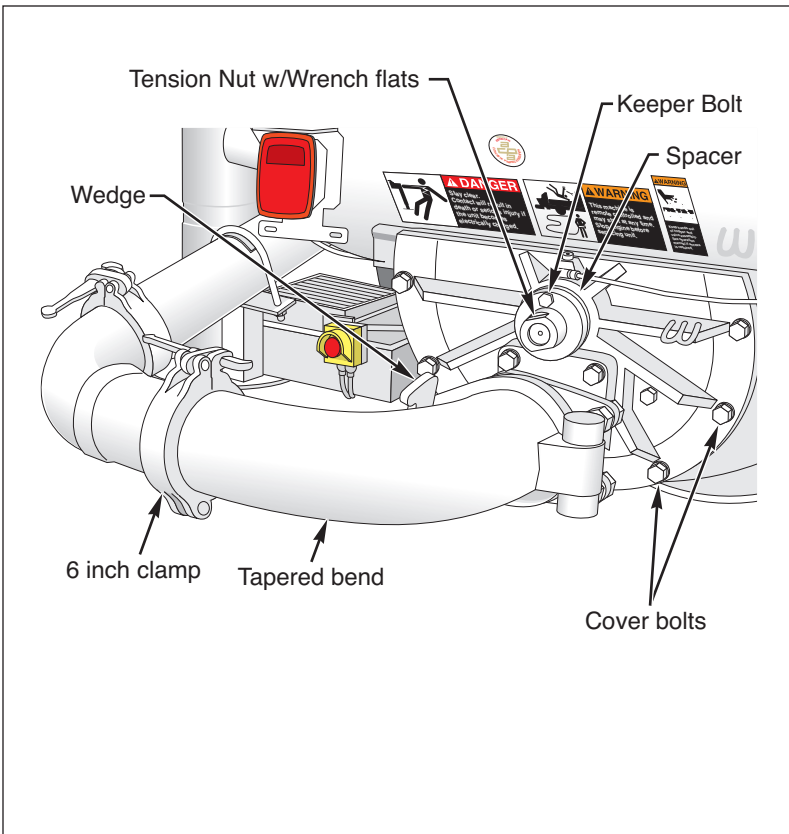

11. Position the hopper grate over the hopper. Bolt it into place.
12. Tighten the tension nut. Tighten the keeper bolt.
13. Push the tapered bend closed and install the wedge. Remember to install the hairpin.
14. Install the 6-inch clamps and the hairpin.

Rock Valve**Replacing the Cutting Ring**

1. Loosen the bolt on the Pivot Lever a few turns with a 30 mm wrench.

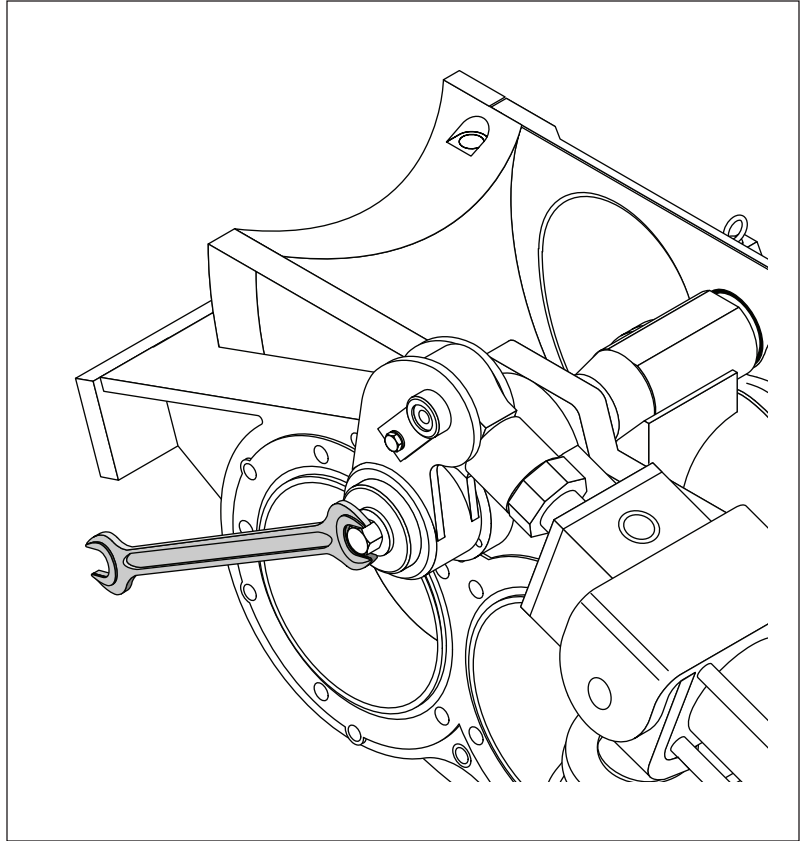

2. Remove the Housing End Cover Bolts with a 36 mm. wrench.

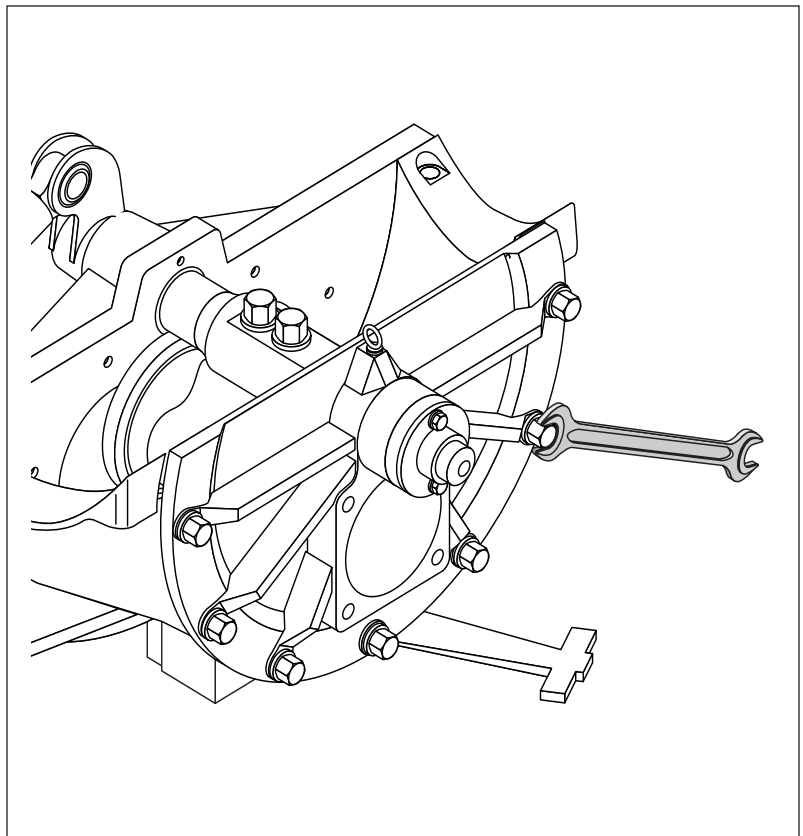

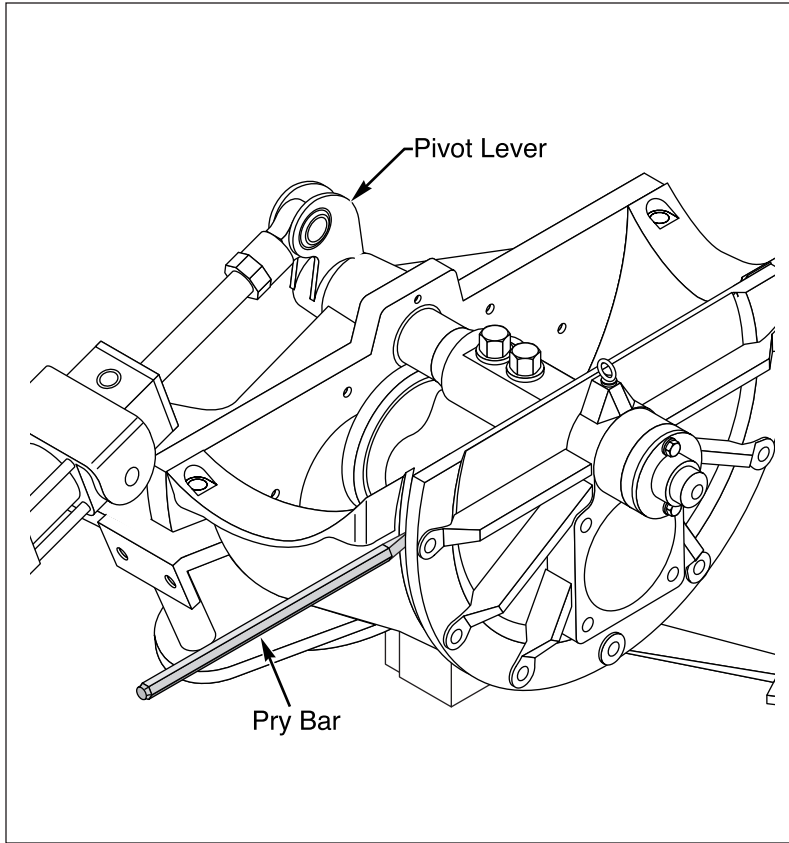

3. Pry the End Cover away from the housing as far as the Pivot Lever will allow.

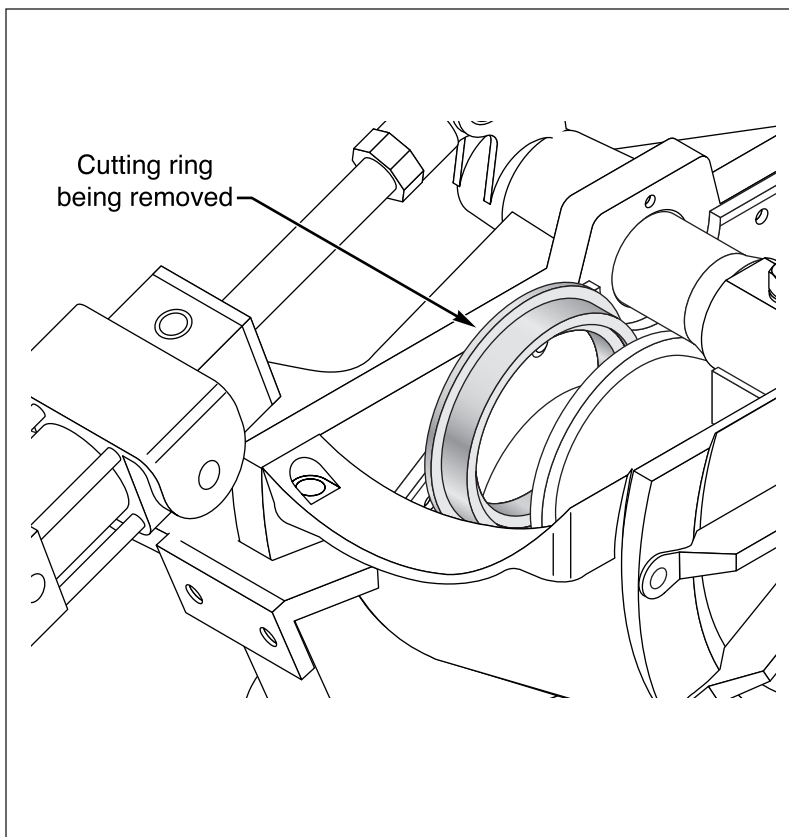

4. Remove the Cutting Ring, and replace it with the new part.
5. When reassembling, make sure that the Cutting Ring fits correctly and that the Pressure Spring is in full contact with the face of the Cutting Ring. Reassembly is opposite to the procedure above.

Rock Valve

Pressure Spring

If the Pressure Spring has to be replaced, dismantle the old spring and clean the vacant area thoroughly to clear it of cement dust, etc. If dust and residue are ignored, the new spring cannot be installed correctly, and the flow of concrete can pull it out of the groove. Furthermore, the high pretension leads to premature wear of the Cutting Ring and Housing Lining.

NOTE: Slightly grease the new Pressure Spring when installing it. The same applies to the Kidney Seal. Do not use too much grease, because grease accumulating in the spring chamber operates as a spacer, and the consequently increased spring pretension can lead to the same damages as described above.

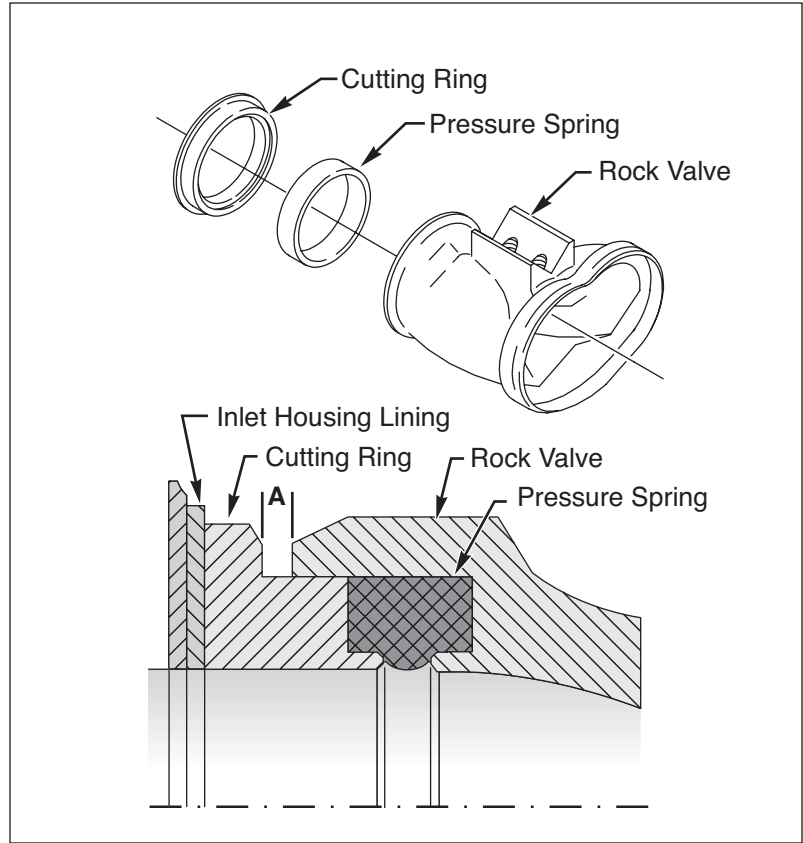

Tension Nut

Do not use the Tension Nut to adjust the position of the Cutting Ring. Excessive wear of the Inlet Housing Lining, Cutting Ring, Pressure Spring, and Kidney Seal would result.

The Tension Nut adjusts the Kidney Seal area of the Rock Valve **ONLY**. To check or adjust, remove the Keeper Bolt will line up with a threaded hole in the Setting Disc. If you are between two holes, loosen the Tension Nut so it lines up with the previous hole. Do not use a wrench to tighten. The flat sides of the Tension Nut are to loosen the nut only. Please call the Schwing Service Department if you have any questions.

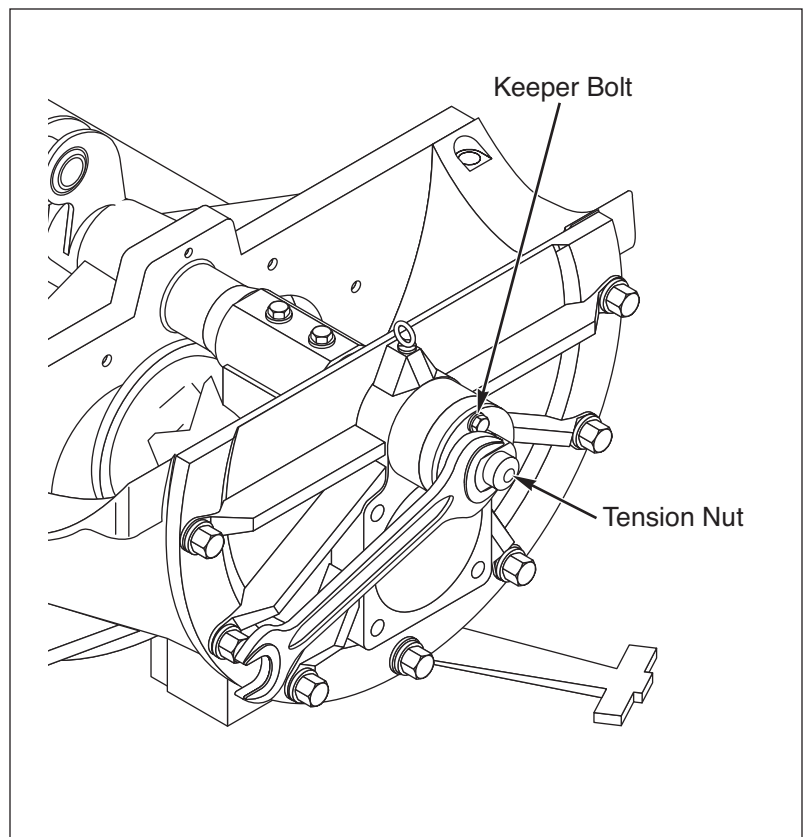

Determining Wear on Kidney Seal and Kidney Plate

Replace the kidney seal if any of the following conditions exist:

- The seal is swollen due to use of aggressive or harsh cleaning agents. (See Service bulletin G-113-84, dated July 18, 1984)
- A considerable formation of cracks are found in the areas marked by arrows. (fig. 1) This problem is very rare.
- Lip (Item 1, fig. 1) is completely worn to the point that the pressure relief grooves (Items 2, fig. 1) are no longer recognizable.
- The distance indicated by “M” of the Kidney Seal (when force is relieved) does not exceed 30mm (1 3/16”).

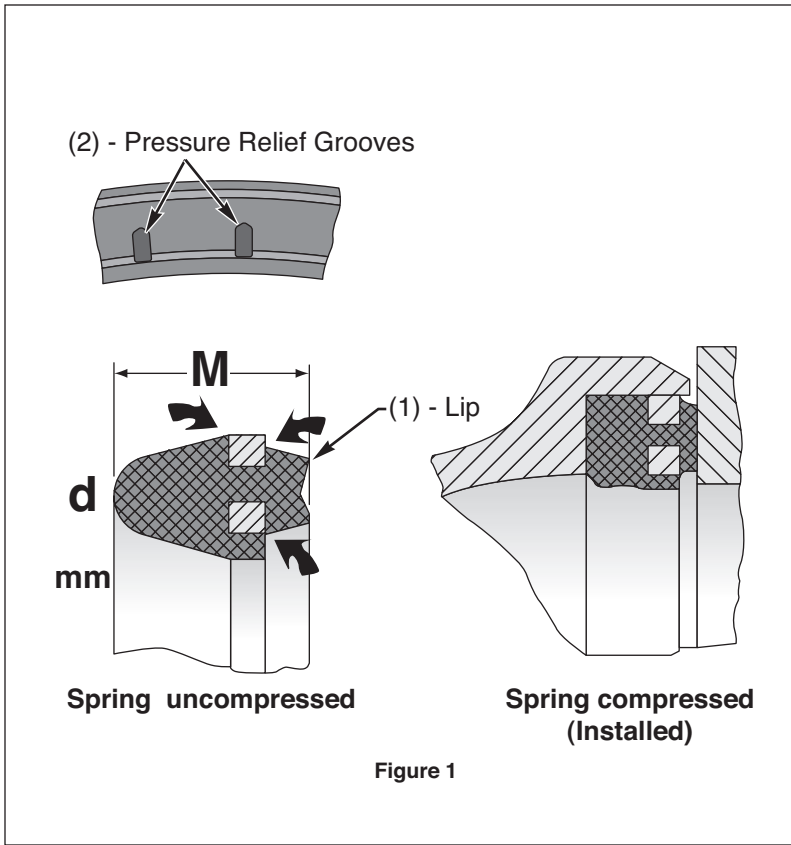

Figure 1

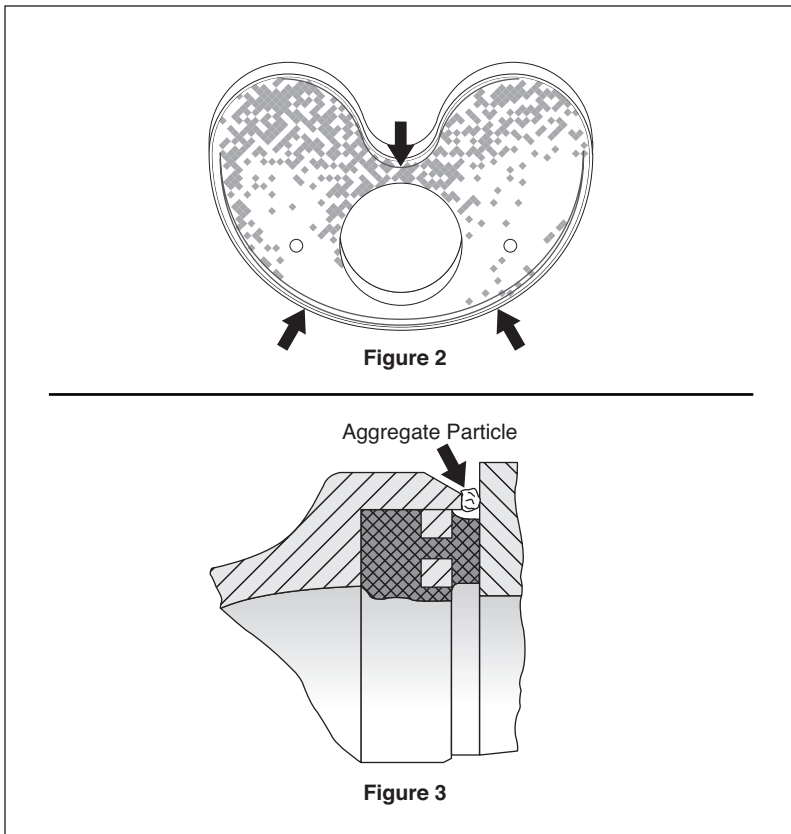

Figure 2

Figure 3

Replace the Housing Lining-Outlet Side (Kidney Plate) only if scores deeper than 2.5mm are found, in the area that contacts the Kidney Seal. You can measure this by placing a steel ruler across the kidney Plate in several places, and using a depth gauge to determine the gap.

NOTE: Outside of the area that contacts the Kidney Seal, you may detect scores that are due to aggregate particles stuck between the Rock Valve and the Kidney Plate. (See fig. 2 and fig. 3) These scores will not affect the operation of the Rock Valve.

Under no circumstances should you allow the Kidney Seal to be run with a dry hopper. This will destroy the Kidney Seal, and is the primary cause of premature wear encountered at the outlet side of the Rock Valve.

If you will be repairing the Rock, or troubleshooting a problem, always fill the hopper with water to the top of the Rock Valve before switching.

Rock Valve

Replacing the Kidney Seal

Kidney Seal

1. Remove the Keeper Bolt from the Tension Nut using a 24 mm wrench.

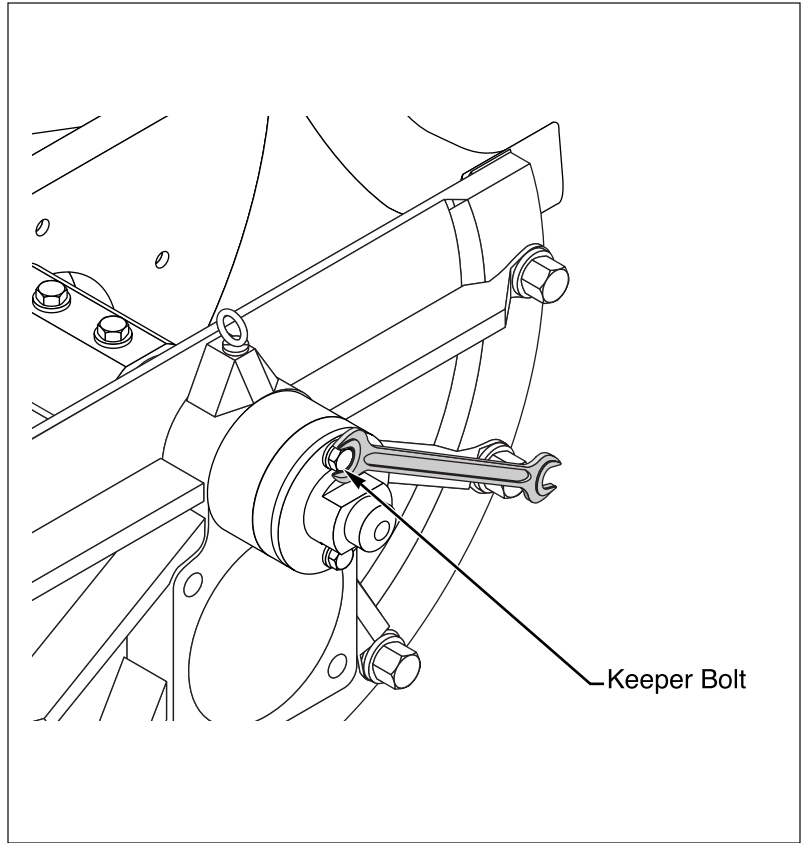

2. Remove the Tension Nut using a 60 mm. wrench.

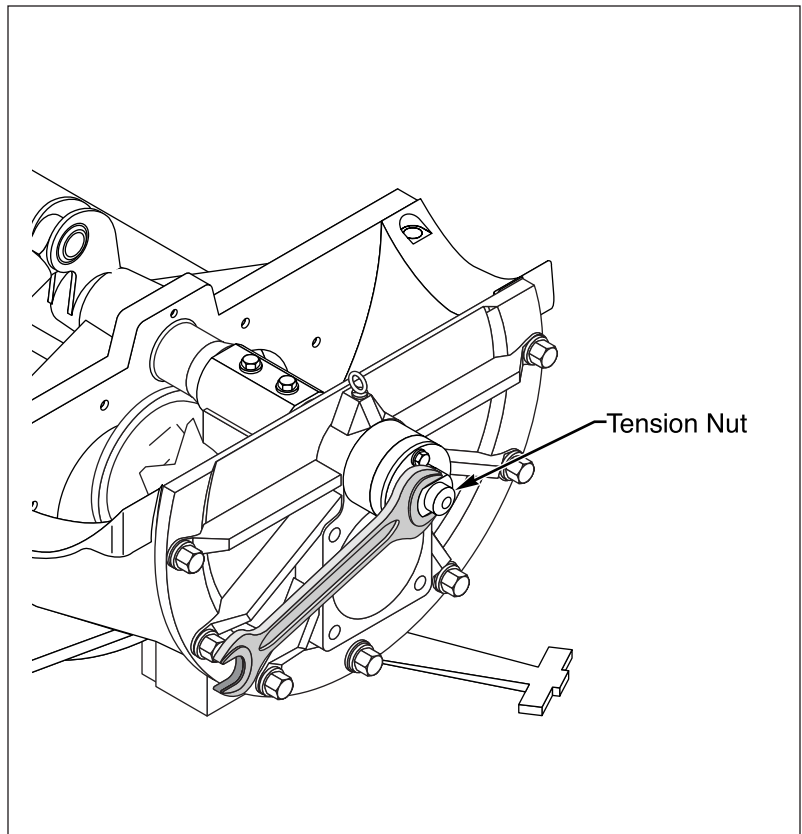

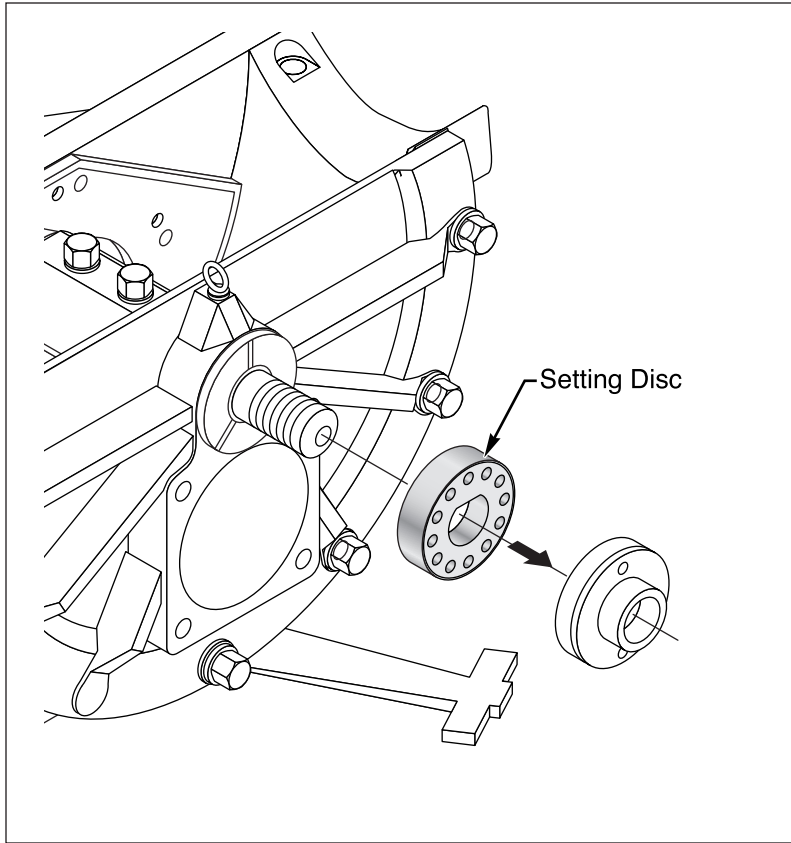

3. Remove the Setting Disc from the Rock pivot shaft.

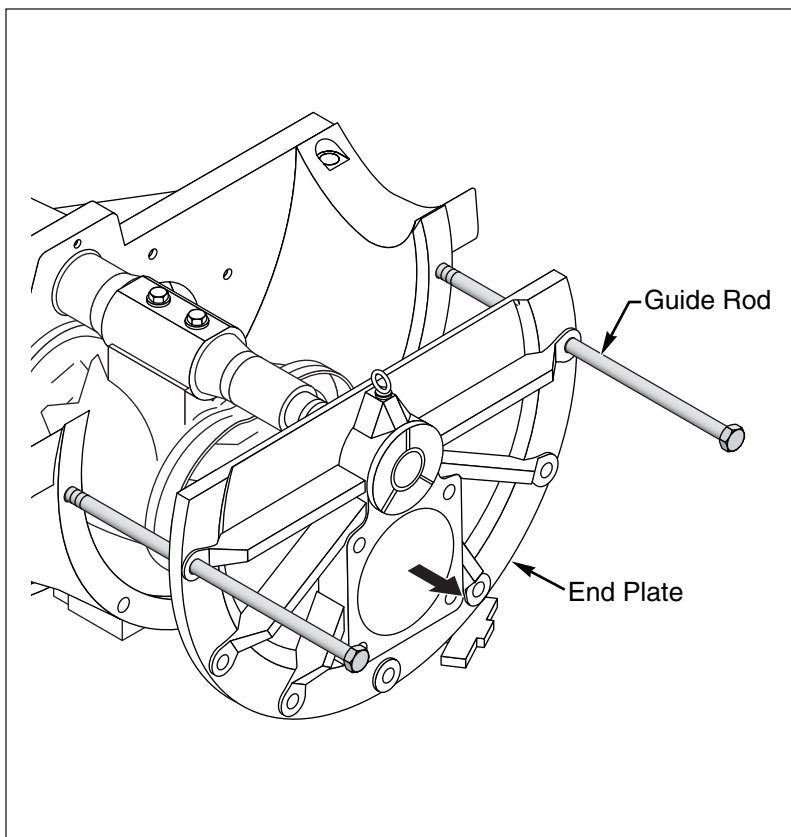

4. Remove the bolts from the End Cover and insert the two Guide/Support Rods into the upper holes using a 36 mm. wrench.

Rock Valve

5. Slide the End Cover along the inserted Guide/Support Rods.
6. Remove the Kidney Seal with a screw driver or similar tool.

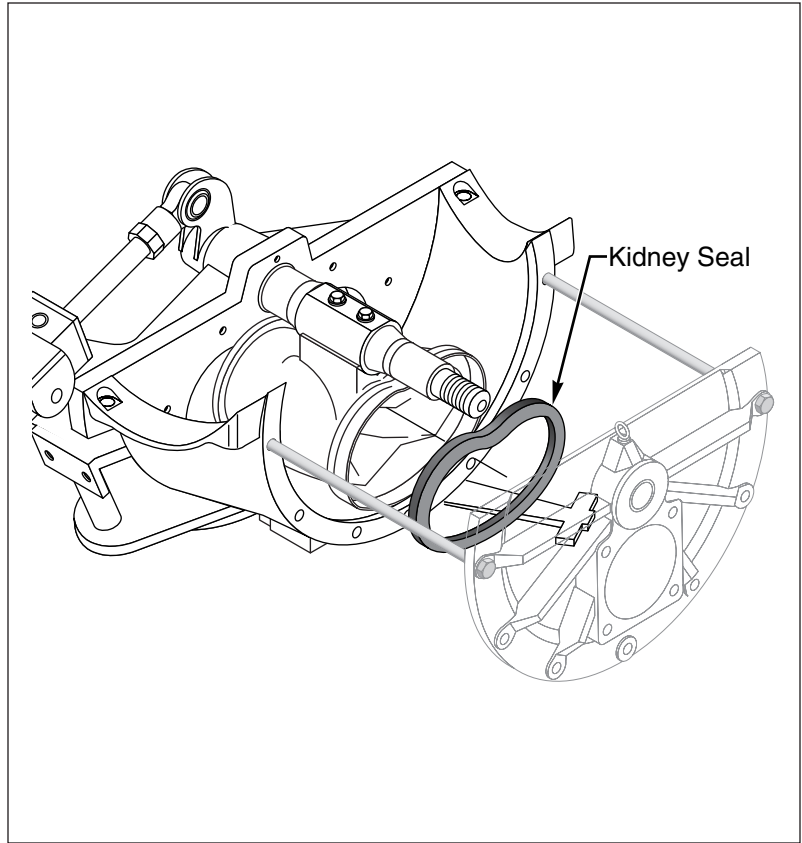

7. Clean the Kidney Seal groove of the Rock Valve thoroughly.
8. Replace the Kidney Seal while making sure that the flat surface is toward the End Cover.
9. Push the End Cover back into place and replace the bolts. Clean away any debris that would prevent the cover from sitting flat.
10. Replace the Setting Disc onto the square portion of the Rock Pivot Shaft.

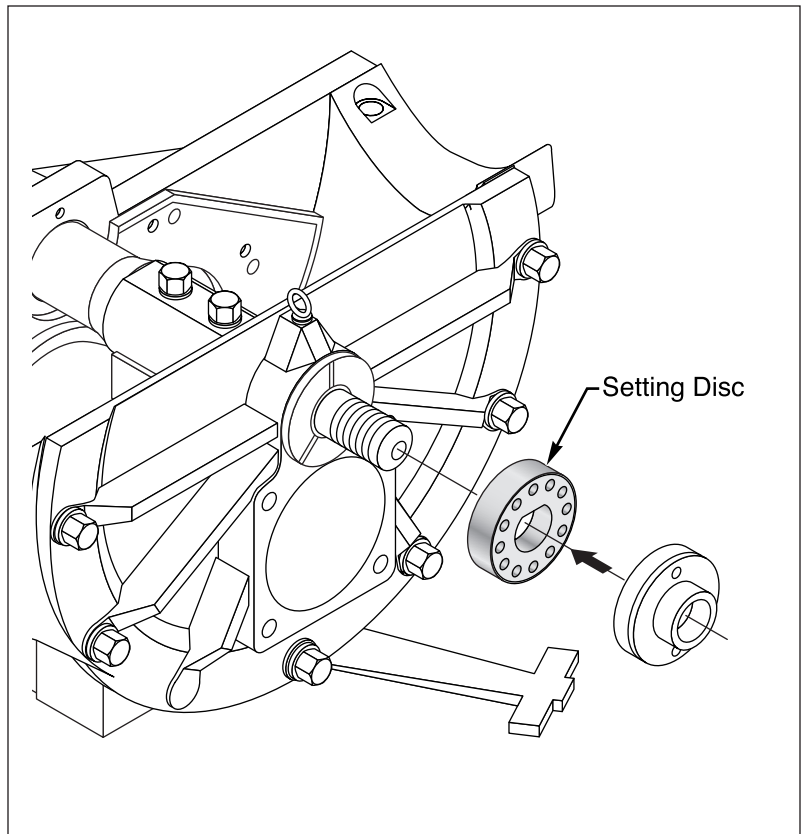

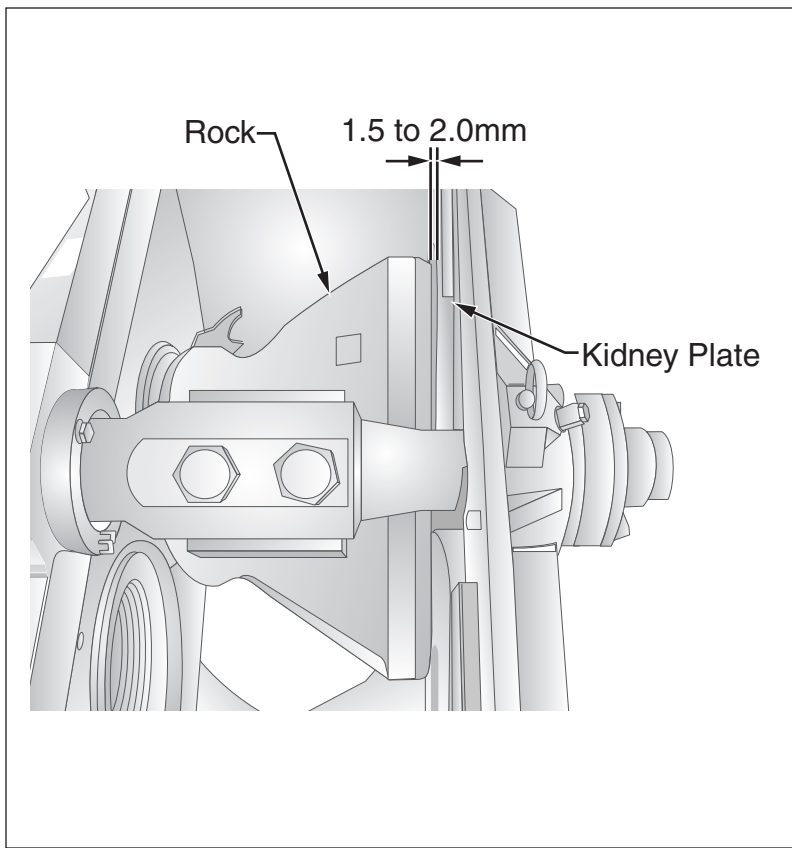

11. Replace the Tension Nut onto the Rock Pivot Shaft, and tighten it by hand. In this position, the clearance between the Rock Valve and the housing should be 1.5 to 2.0 mm.

NOTE: If either the Spectacle Plate or the Cutting Ring are not replaced at the same time as the Kidney Seal, the clearance will be greater and can be adjusted by further tightening of the Tension Nut to the next Setting Disc hole only.

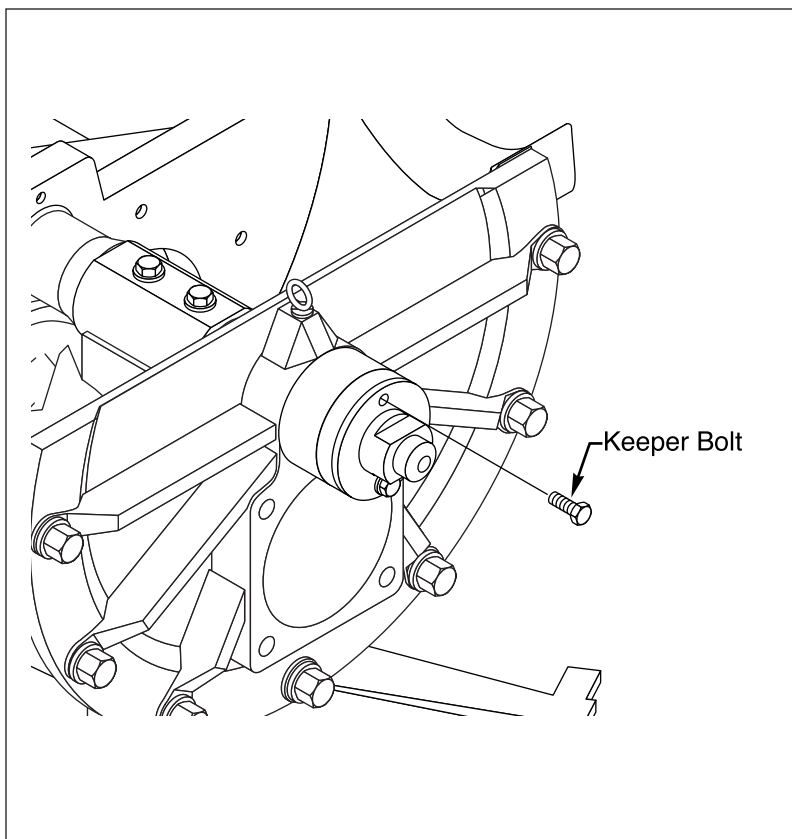

12. Replace the Keeper Bolt.
13. **IMPORTANT!** At no time should the Rock Valve be operated without first lubricating the outlet wear plate. Usually, spraying the plate with water or oil prior to start-up will be adequate. Moving the kidney seal against a dry plate will cause excessive wear to the seal and will lead to premature failure. If switching the Rock Valve is necessary for shop work (adjusting, inspecting, etc.), you must take the necessary precautions and ensure that the plate and seal are properly lubricated.

Spectacle Plate

Lengthening the Service Life

The amount of wear on the Housing Lining and the Cutting Ring will vary, and it will affect the length of time they can safely be used. The condition of each part depends on outside influences that affect them daily, including varying concrete mixes and changing weather conditions. The Cutting Ring and Housing Lining cannot be expected to wear equally and will need to be replaced accordingly.

NOTE: The grooves in the Base Plate (Spectacle Plate) resulting from basic operation are irrelevant as long as the hard facing is in good working condition.

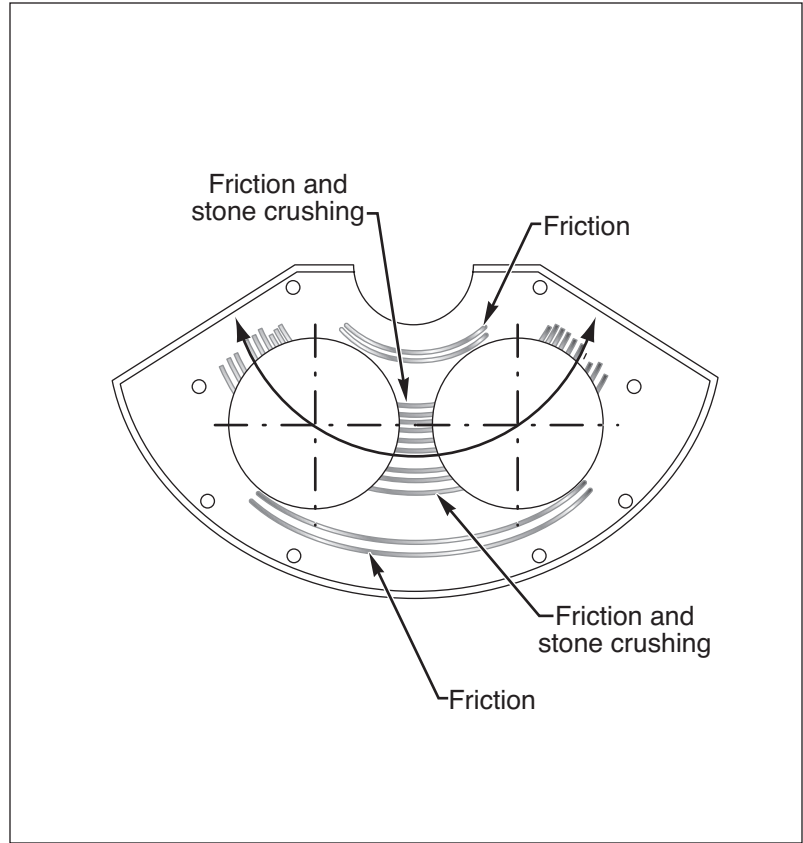

To assist in achieving uniform wear and, thus, considerably longer service lives, we recommend:

1. Moving the Rock Valve to the left and right end positions once a week--after thorough cleaning--and checking the condition of the cutting ring & housing lining.
2. Turning the Cutting Ring 90 degrees if there is a visible space between the Cutting Ring and the Housing Lining that is greater than 1.0-1.5 mm. (.0393"-0.0590"). Check for this gap at several points along the circumference. Instructions for cutting ring can be found on page 6 of this document.

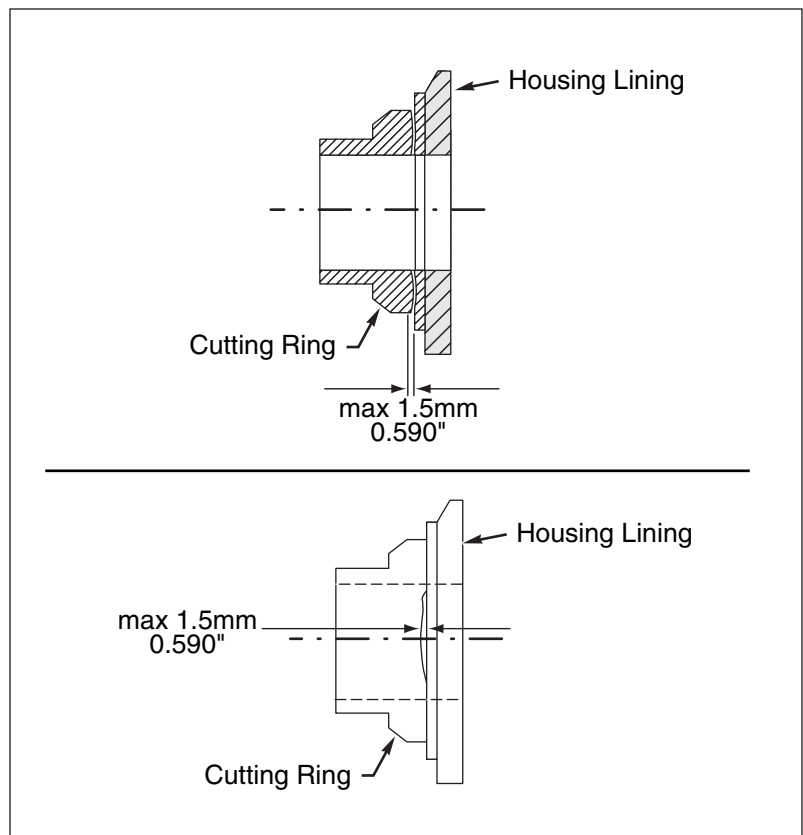

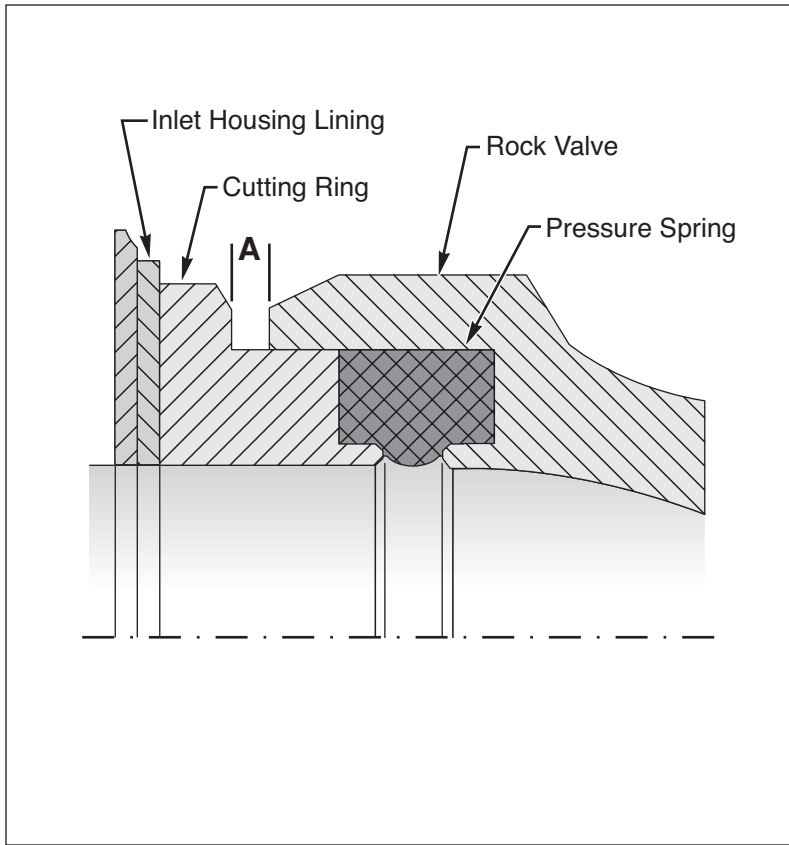

3. Checking the distance between the Cutting Ring and the Rock Valve after each turn of the Cutting Ring. If it exceeds 8 mm. (.31"), the pretension of the Pressure Spring is not enough to correctly press the Cutting Ring to the inlet side of the Housing Lining, and the Cutting Ring should be changed.

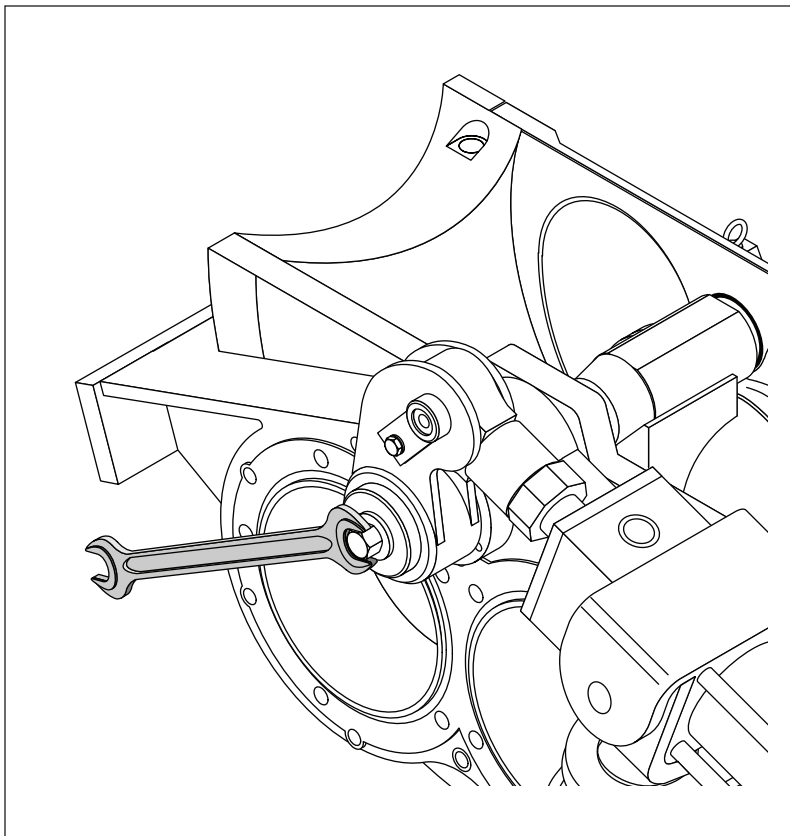

Replacement of Spectacle Plate

Check the plate for wear, and if replacement is necessary, follow these steps:

1. Loosen the bolt on the Pivot Lever a few turns with a 30 mm. wrench.

Rock Valve

2. Remove the Housing End Cover Bolts with a 36 mm. wrench.
3. Pry the End Cover away from the Housing Cover as far as the Pivot Lever will allow.

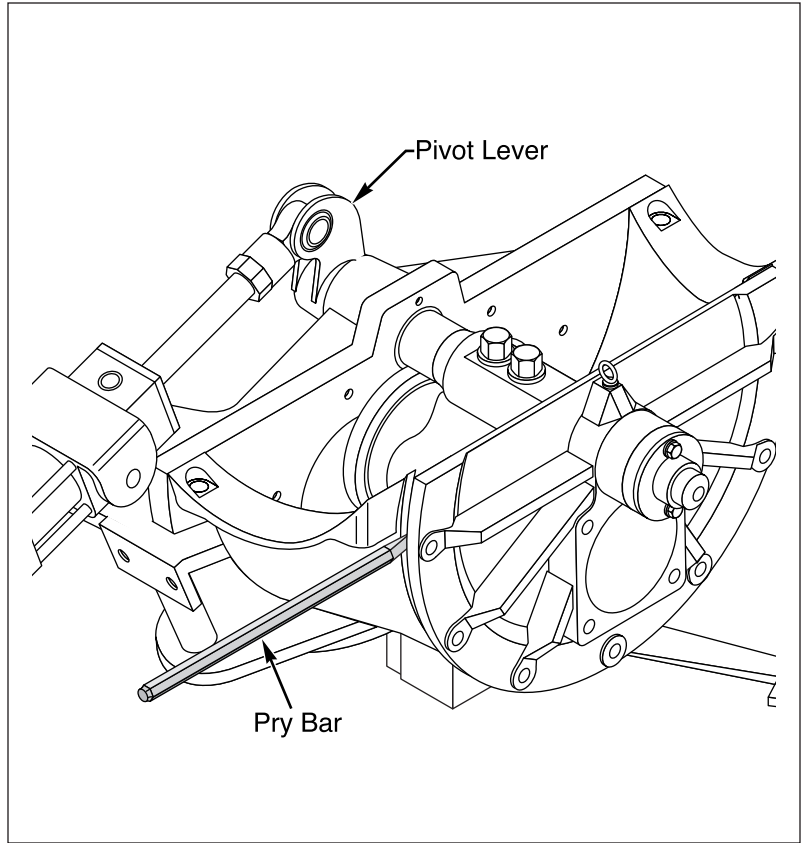

4. Using a 14 mm. allen wrench, remove the socket head bolts that secure the plate.

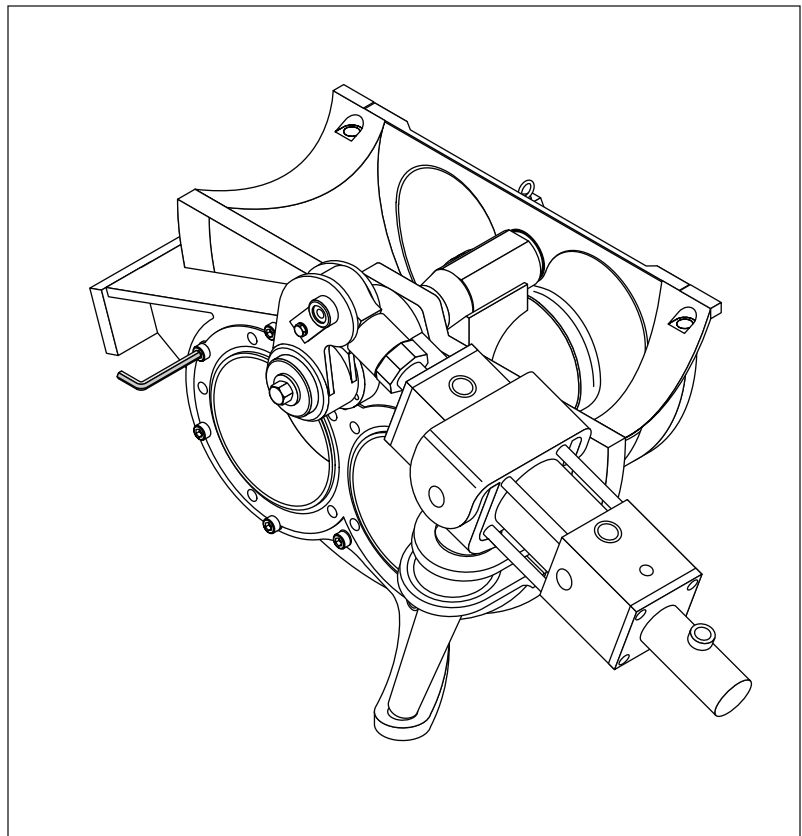

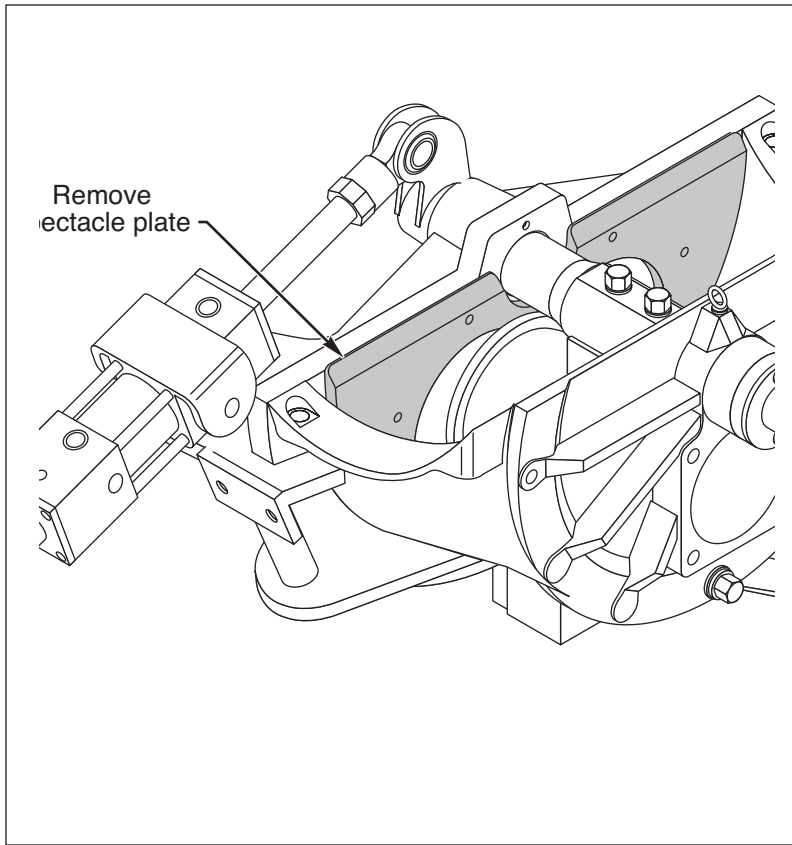

5. Pry the Spectacle Plate (Base Plate) away from the pumping cylinders.

NOTE: In some old models, the transition pieces may come out with the Spectacle Plate. If this becomes a problem, see Service Bulletin G-104/89 for assistance.

6. Thoroughly clean the area where the plate is to be mounted, install the new Spectacle Plate, and secure it. Reassembly requires following the above steps in reverse order.

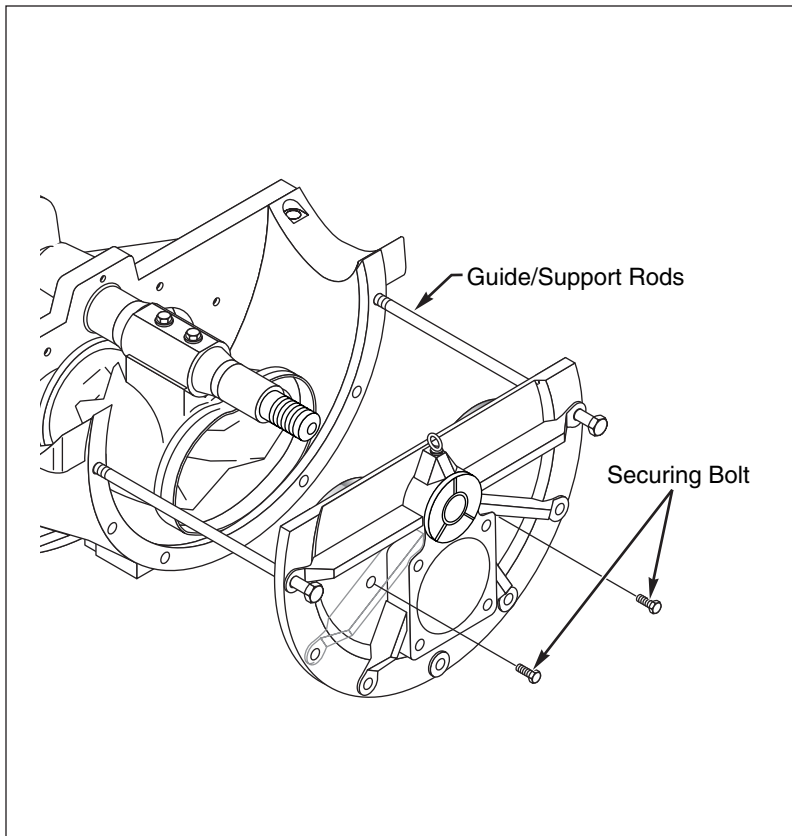

Replacement of Outlet Housing Lining (Kidney Plate) Plate

Check the plate for wear, and if replacement is necessary, follow these steps:

1. Remove the Keeper Bolt from the tension nut using a 24 mm. wrench.
2. Remove the Tension Nut using a 60 mm. wrench.
3. Remove the Setting Disc from the Rock Pivot Shaft.
4. Remove the bolts from the End Cover and insert the two Guide/Support rods into the upper holes using a 36 mm wrench.
5. Slide the end cover along the inserted Guide Rods.
6. To replace the lining, remove both Securing Bolts in the End Cover using a 24 mm wrench.

Rock Valve

- Free the lining from the End Cover, and remove it. It is heavy...get help if needed

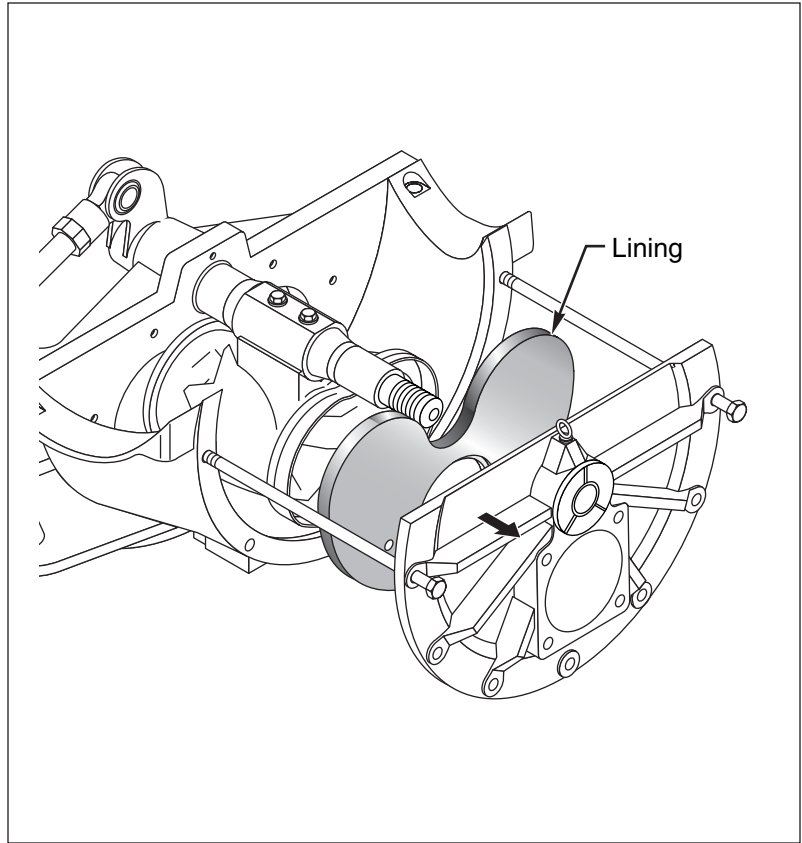

- Thoroughly clean the entire area that the Outlet Housing Lining touches.
- Fit a new O-ring into the replacement lining, and reassemble by following steps 1-7 in reverse order.

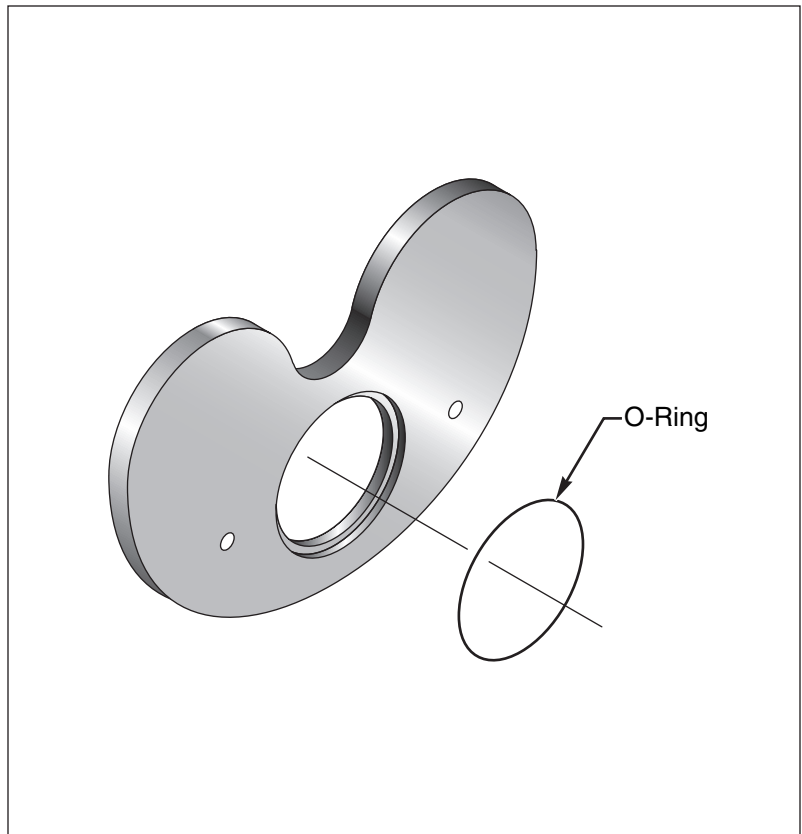

Replacement of Outlet Insert (Cover Lining)

(To be replaced at the same time as the Kidney Seal and/or Outlet Housing Lining.)

1. Remove the Tapered-Bend (Reducing Elbow) from the Pipe Bend (Connection Piece).

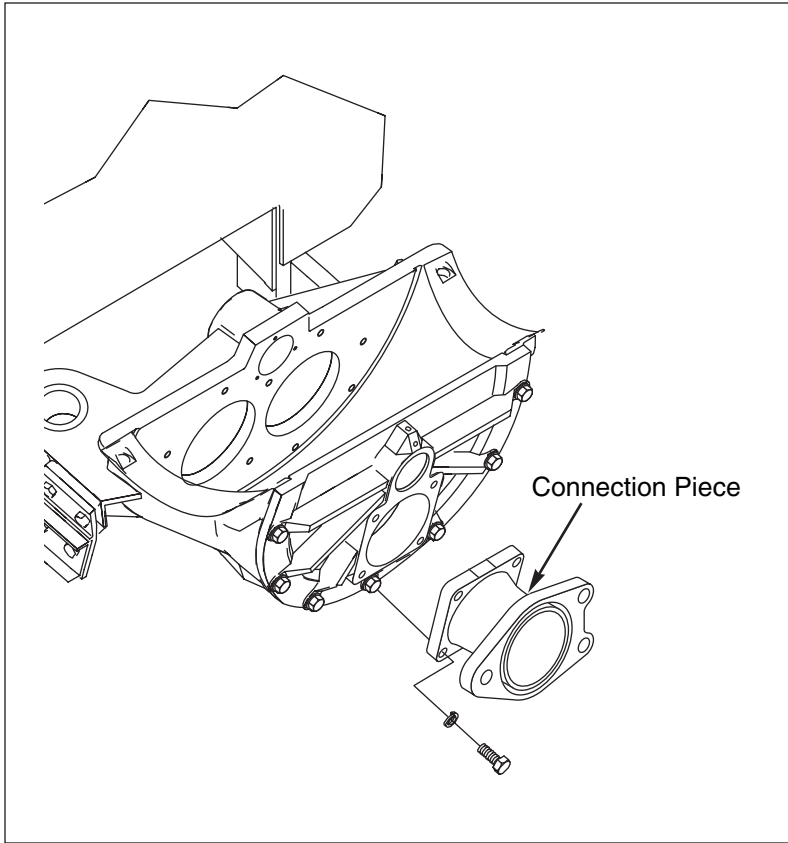

2. Remove the Outlet Housing Lining (Kidney Plate) as described in the **Replacement of Outlet Housing Lining** section.
3. Remove the Pipe Bend from the End Cover.
4. Press out the Cover Lining.

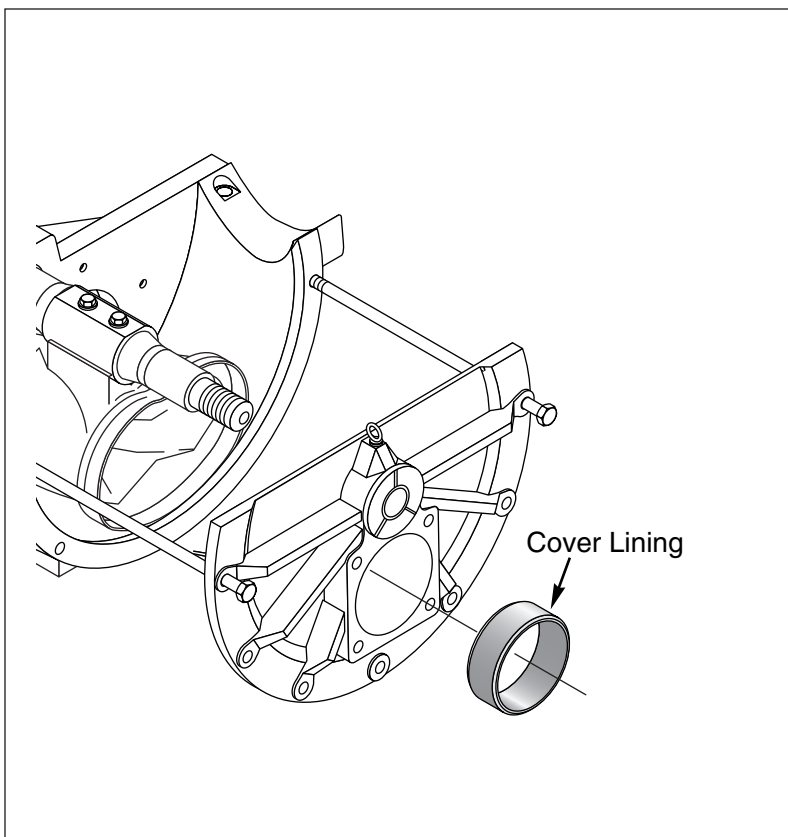

Rock Valve

5. Grease the outer surface of the Cover Lining before reinstalling it into the End Cover.
6. Clean all of the contacted areas, replace the O-ring, replace the Pipe Bend, and reassemble by following the above directions in reverse order.

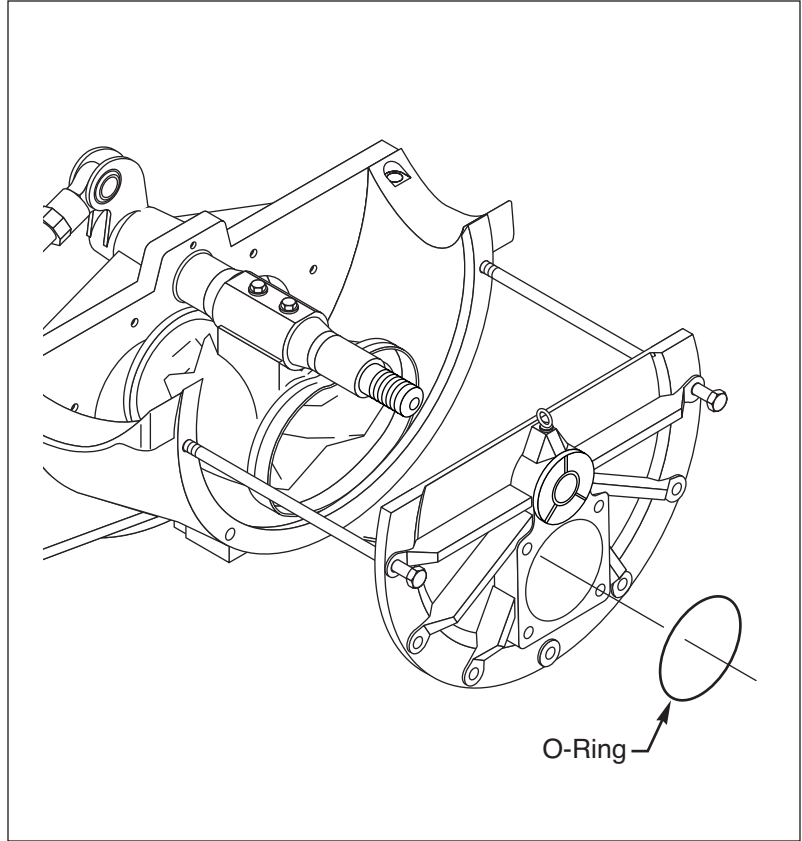

Rock Valve Body

Because this is a major procedure, we recommend close inspection of the Spectacle Plate (Base Plate), Outlet Housing Lining (End Cover Lining), and all other parts that require periodic replacement, so you can replace all necessary parts at the same time.

1. Remove the agitator motor along with the hydraulic lines that are connected to it.
2. Remove any and all electric wires from the hopper. Mark the wires to aid in reassembly.
3. Completely remove the hopper.
4. Remove the End Cover as explained in the Kidney Seal or Outlet Housing Lining replacement section.
5. Remove the bolts from the Rock Valve while making sure to support it from underneath.

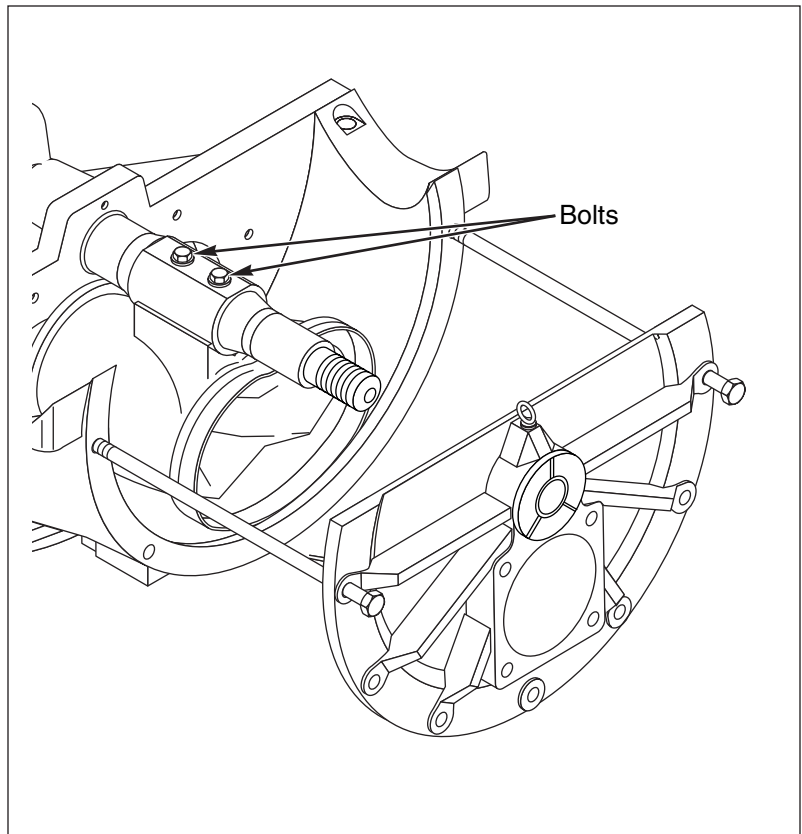

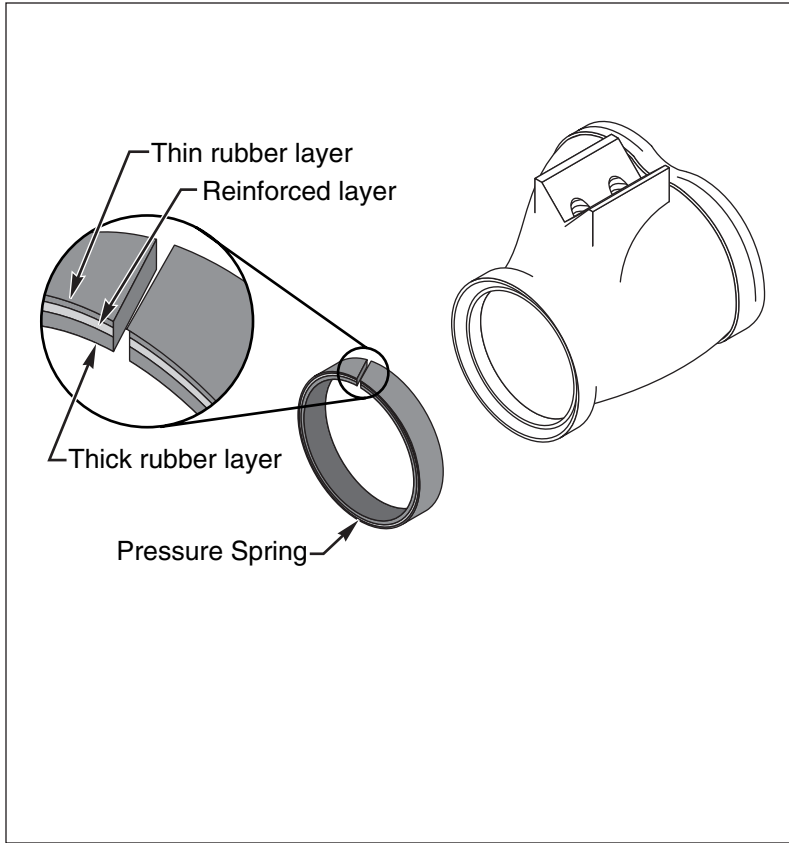

6. Remove the Rock Valve body.

7. Install new rubber seals.

IMPORTANT: Be sure that the Pressure Spring is properly inserted into the housing (most easily done by hand).

The thick rubber goes on the inside towards the concrete.

8. Check the condition of the Rock Pivot Shaft Bushings, as well as the condition of the parts mentioned in the note above, to see if anything else needs to be replaced while you've got the unit disassembled.

9. Reassemble the Rock Valve in reverse order.

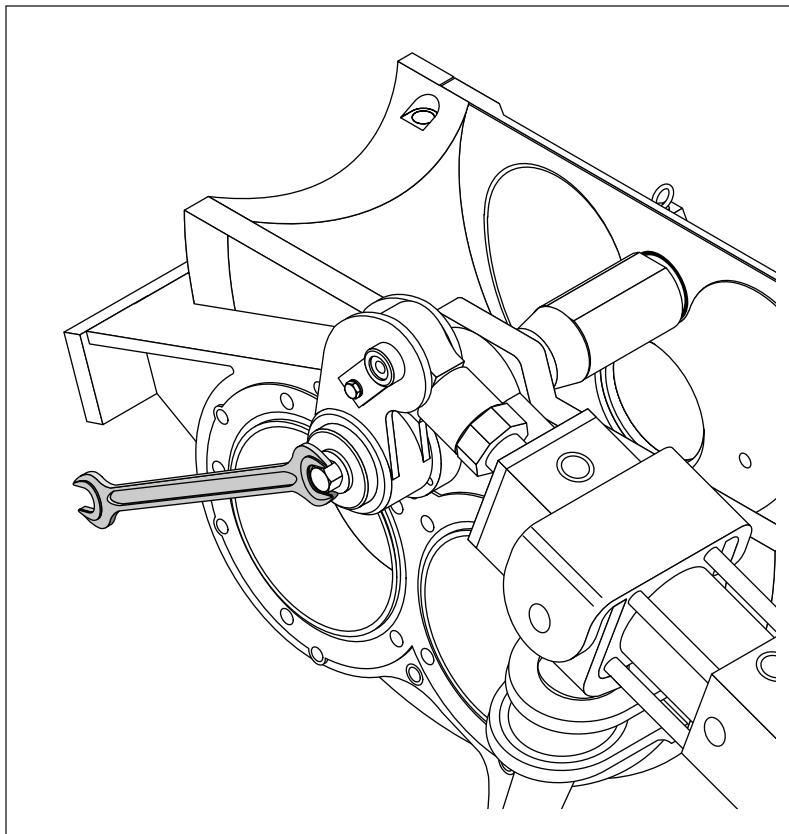

Pivot Shaft

1. Remove the Rock Valve as described in the previous section.

2. Remove the Pivot Level Bolt and Cover Plate.

Rock Valve

- 3. Remove the Pivot Cylinder Pin Retainer Bolt and Keeper Bar.

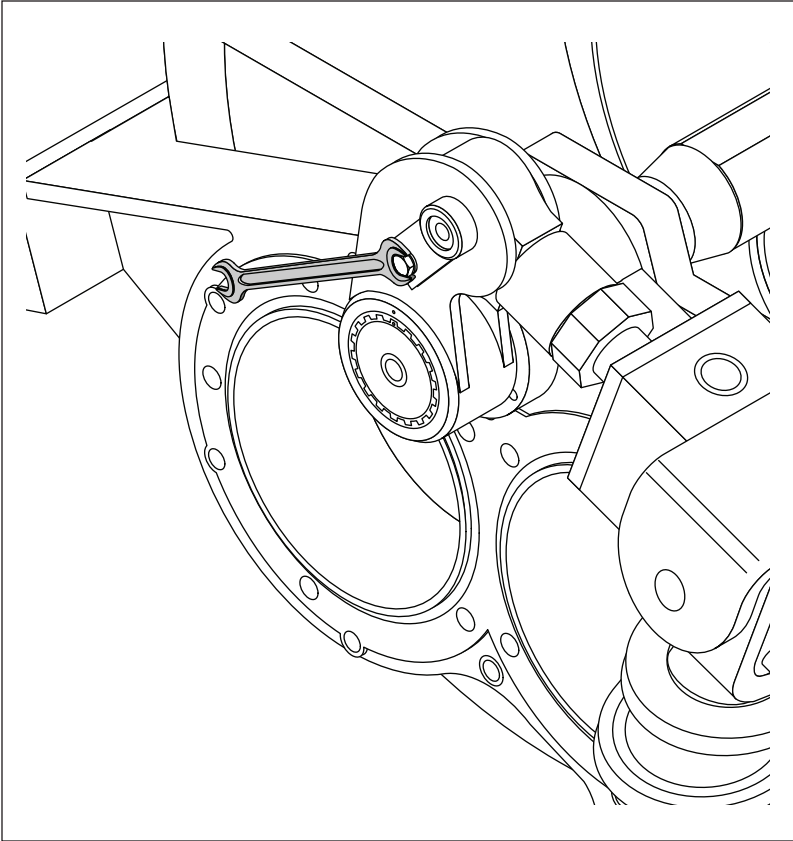

- 4. Remove the Pivot Cylinder Pin from the slewing lever.

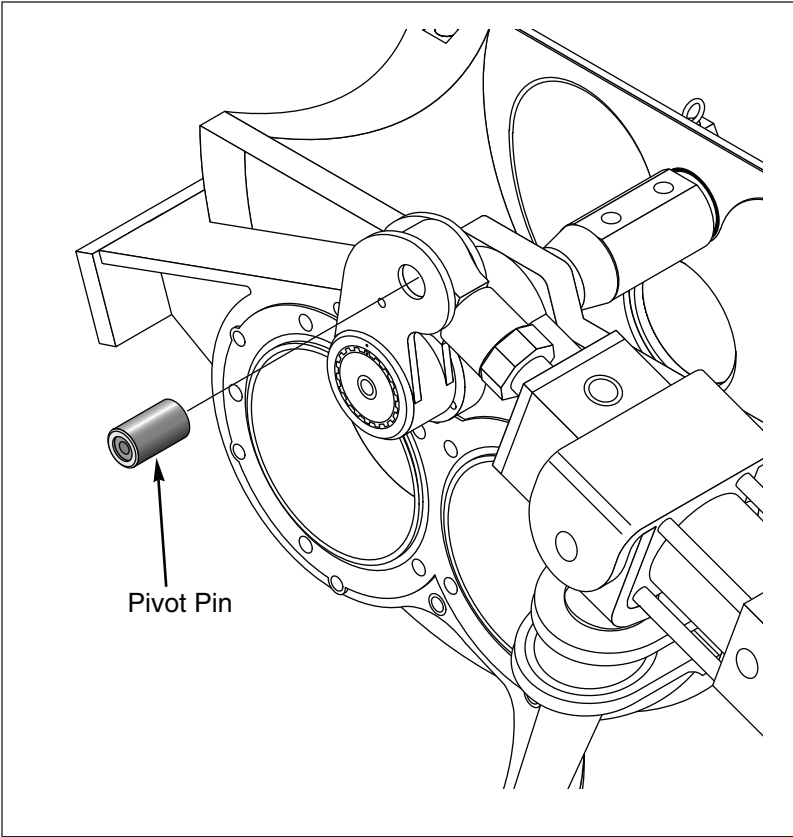

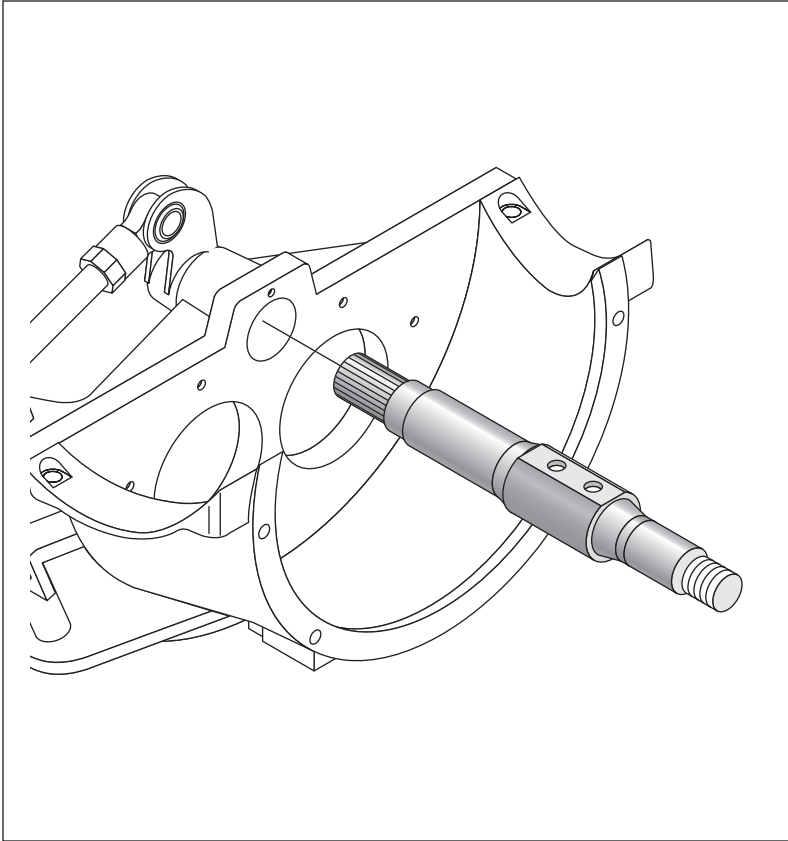

5. Move the Pivot Lever away from the Cylinder Rod, and remove it from the shaft.
6. Remove the Pivot Shaft from the Bearing Housings.
7. Examine and, if necessary, replace the bearing bushings as described later.

NOTE: The pivot shaft seals should always be replaced when replacing the Pivot Shaft.

8. Install the Pivot Shaft with the alignment marking on the top.

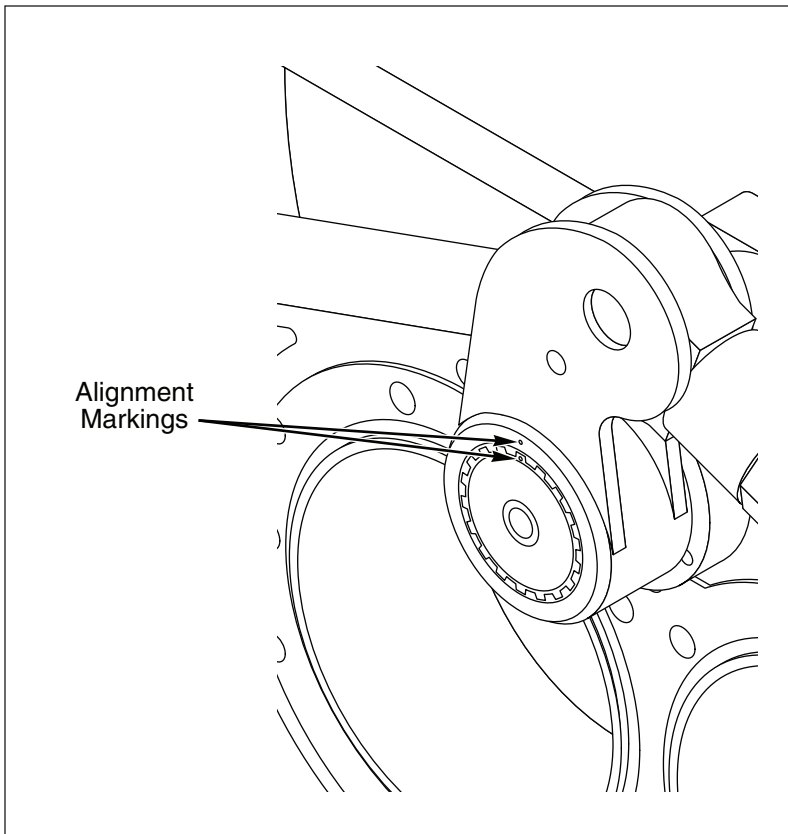

9. Assemble the Pivot Lever onto the Pivot Shaft, making sure the markings are in alignment.

IMPORTANT: If the markings are not correctly aligned, the Cutting Ring will not cover the ports in the Spectacle Plate.

Rock Valve

Pivot Shaft Bushing

1. Remove the Pivot Shaft as described in the Pivot Shaft replacement section of this manual.
2. To replace the bushings, remove the Seal Cover and Bolts.

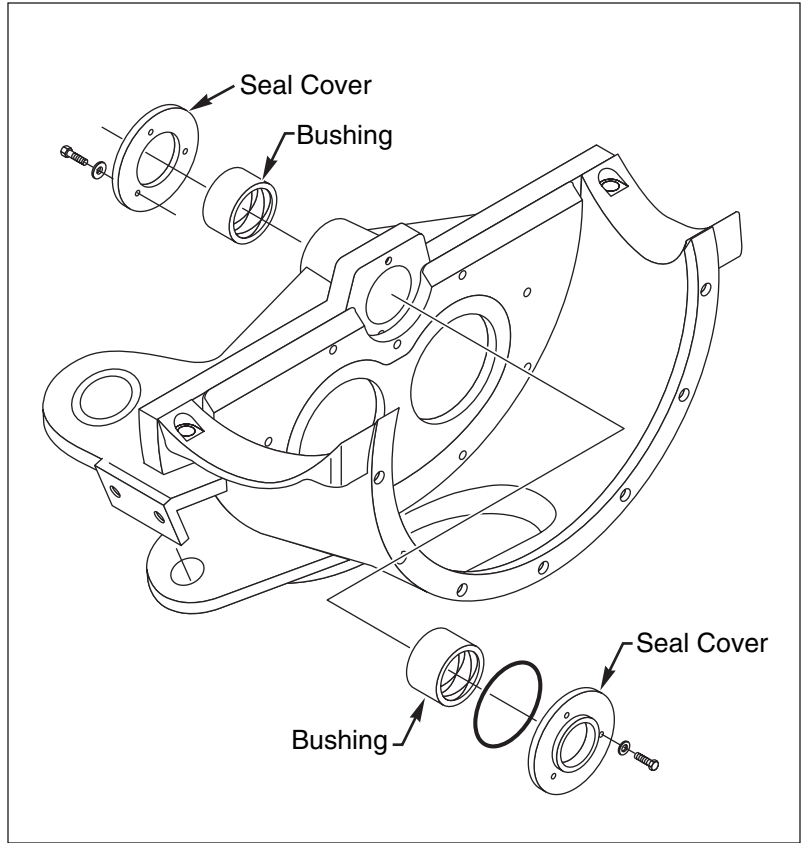

3. Remove the bushings from the housing.

4. Clean the housing bores.

NOTE: To replace the bushings, use the installation tool. (Part# 10013417)

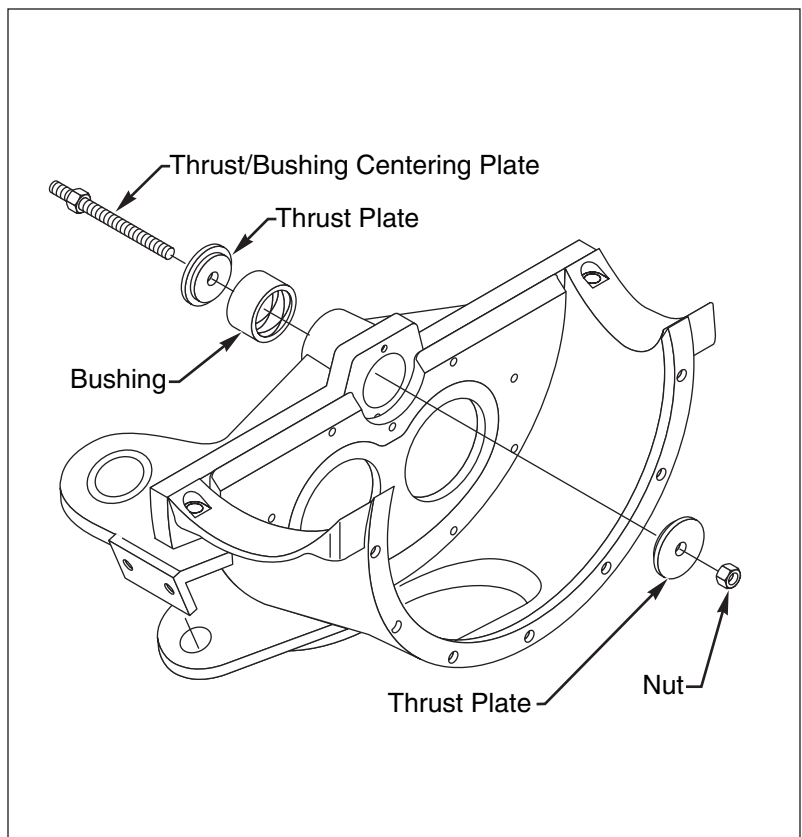
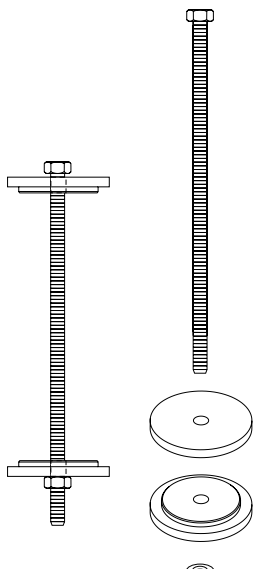

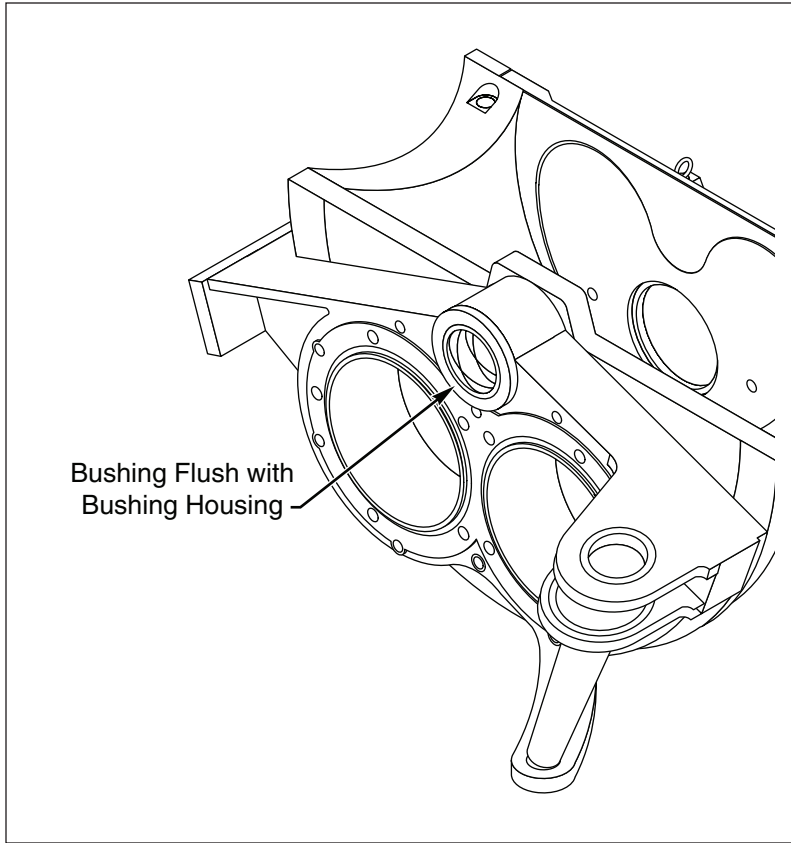

5. Fit the rear bushing (pivot lever side) first with a 46 mm wrench.
6. Insert the bushing so that it is flush with the end of the bushing housing.

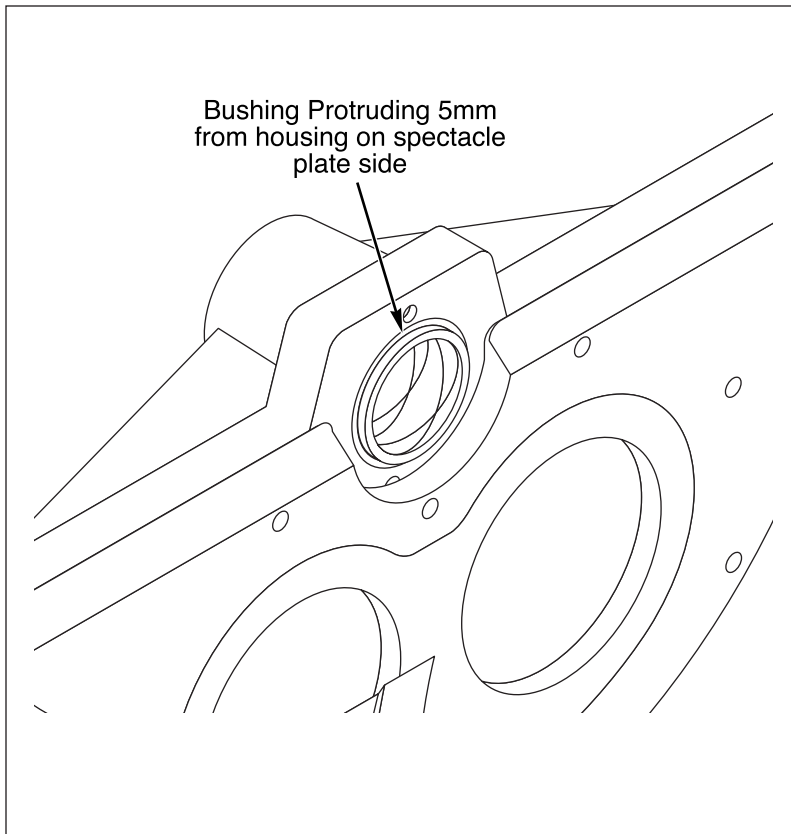

7. Now replace the front bushing (Spectacle Plate Side) with the installation tool, tightening the nut from the opposite end.

NOTE: When the bushing is correctly installed, it will protrude 5 mm from the housing on the Spectacle Plate side.

Rock Valve

8. Install a new O-ring into the Seal Cover, and secure the Seal Cover onto the 5 mm of protruding bushing.

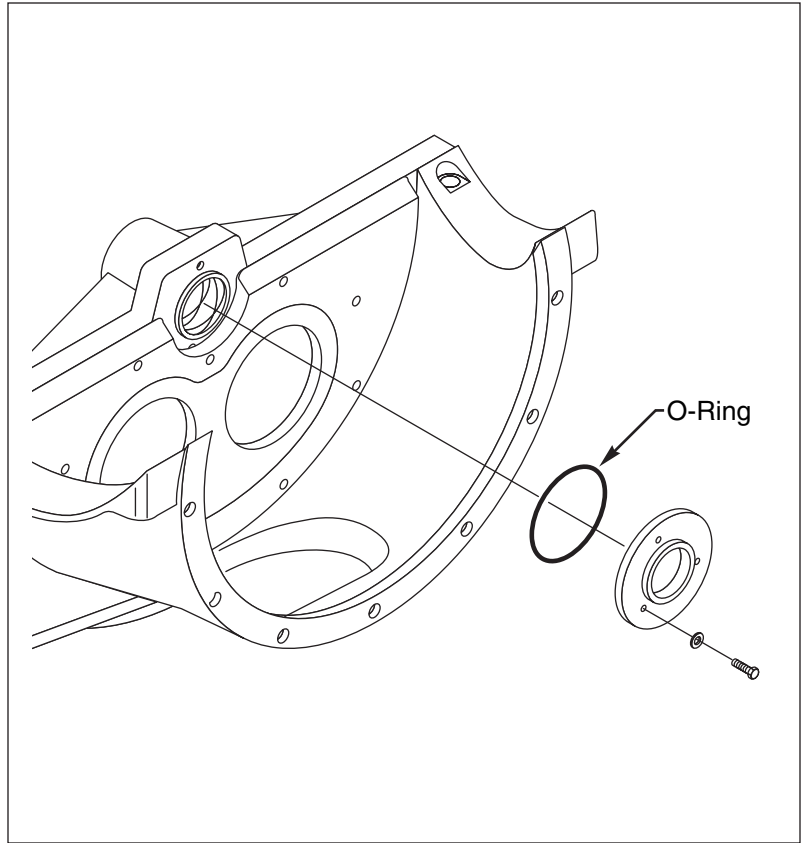

9. Remove the Bushing from the End Cover using a hydraulic press or similar tool.
10. Thoroughly clean the Bushing housing bore.
11. Install the new Bushing using the installation tool, and ensure that it is fully in place.
12. Install a new O-ring into the seat.
13. Install the Pivot Shaft as described in the Pivot Shaft replacement section of this manual.
14. Finally, inject grease through the grease zerks provided.

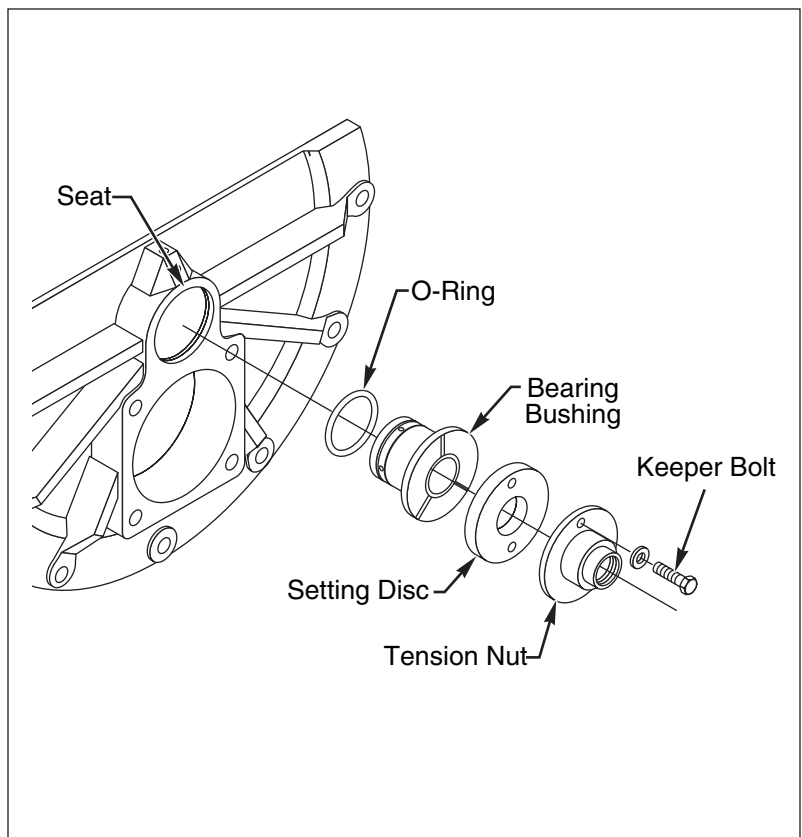

Setting Pivot Angles

After any repairs or dismantling, the pivot angles must be checked and reset, if necessary.

1. The distance between the Pivot Pin and the Cylinder Body must be approximately 185 mm (7 9/32") with the cylinder fully retracted.

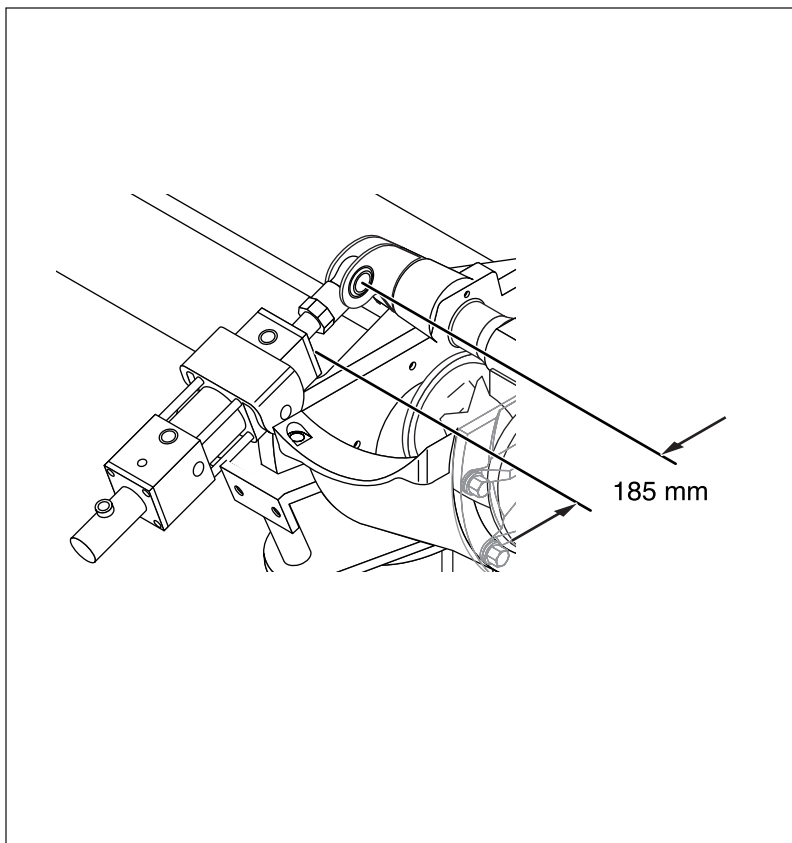

2. To adjust the correct setting, loosen the Piston Rod Locknut and adjust as required.

NOTE: After approximately setting the Piston Rod, check that the Rock Valve travels across the Spectacle Plate, and ensure that the Cutting Ring is centered over each port. When stopped in the end position equally on both sides.

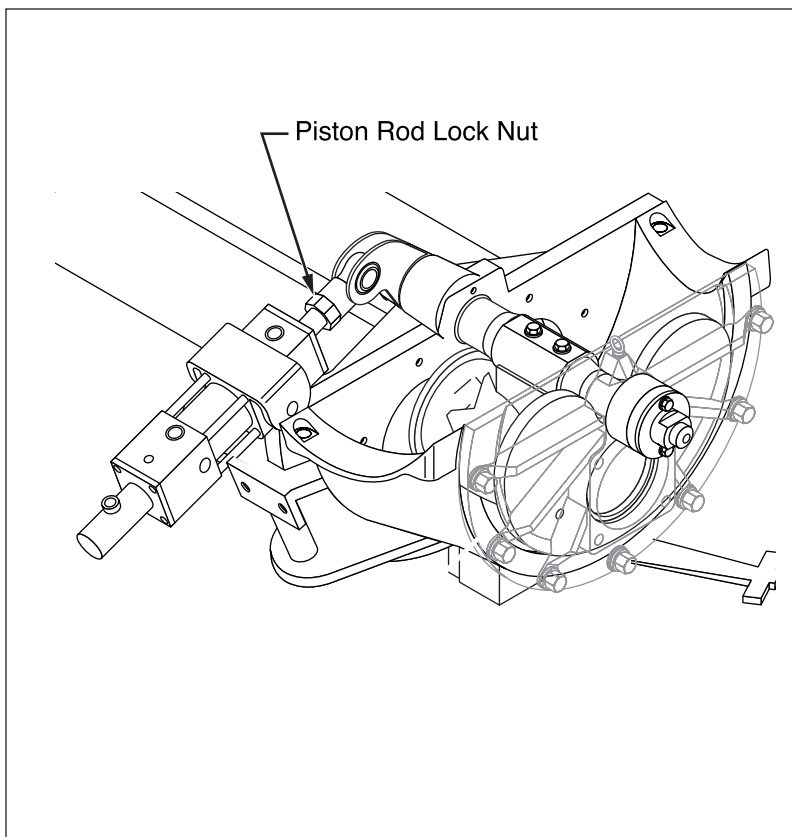

3. To check the setting, fully unscrew the pressure reducing valve and close the ball cock. Then, move the pivot cylinder to the end of its stroke.
4. In this position, check that the ports are completely covered by the cutting ring by looking through the pipe bend (connection piece). If they are not, make adjustments using the Piston Rod.
5. After the setting is checked, tighten the locknut onto the Piston Rod.

Rock Valve**Replacement of Pivot Shaft Bushings**

When changing the pivot on a Rock Valve Slewing Cylinder, please be sure that you install new bushings in the pivot eyelets. These bushings are not automatically shipped with a pivot, so please order them with the pivot if you don't have them in stock. The part number for this bushing is: 10006726.

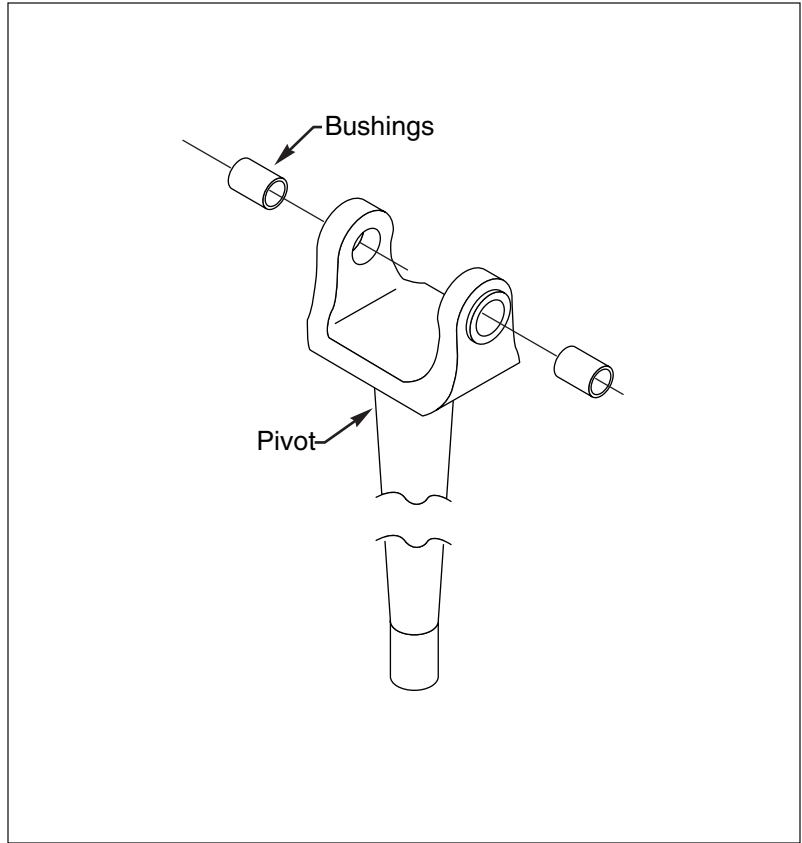

Also, when you change the pivot, we recommend that you change the Pivot Bushings, if your unit has the thin, teflon coated bushings. The part number on these thin bushings is: 10016324. If your unit has the thick, steel bushing, you need not change it out. To tell if your unit has a thin or thick bushing, you must remove the rock cylinder from the rock housing. The thick bushing is one piece, about 1/4" thick. The thin bushings are in two pieces. If you don't want to pull your slewing cylinder just to find out, we would recommend ordering the thin bushings. If you don't need them, return them to us for credit.

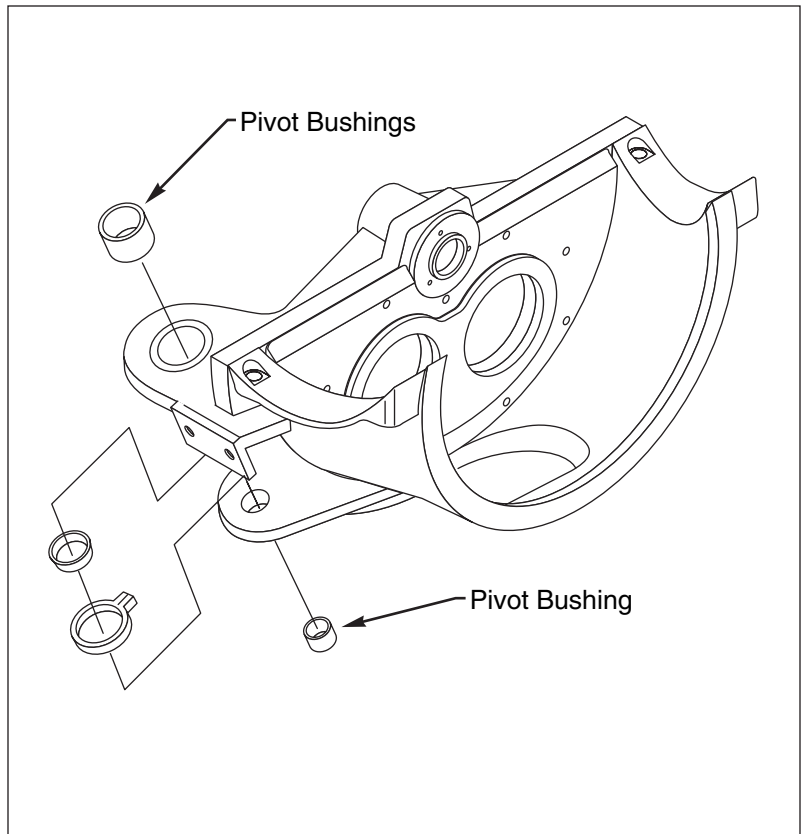

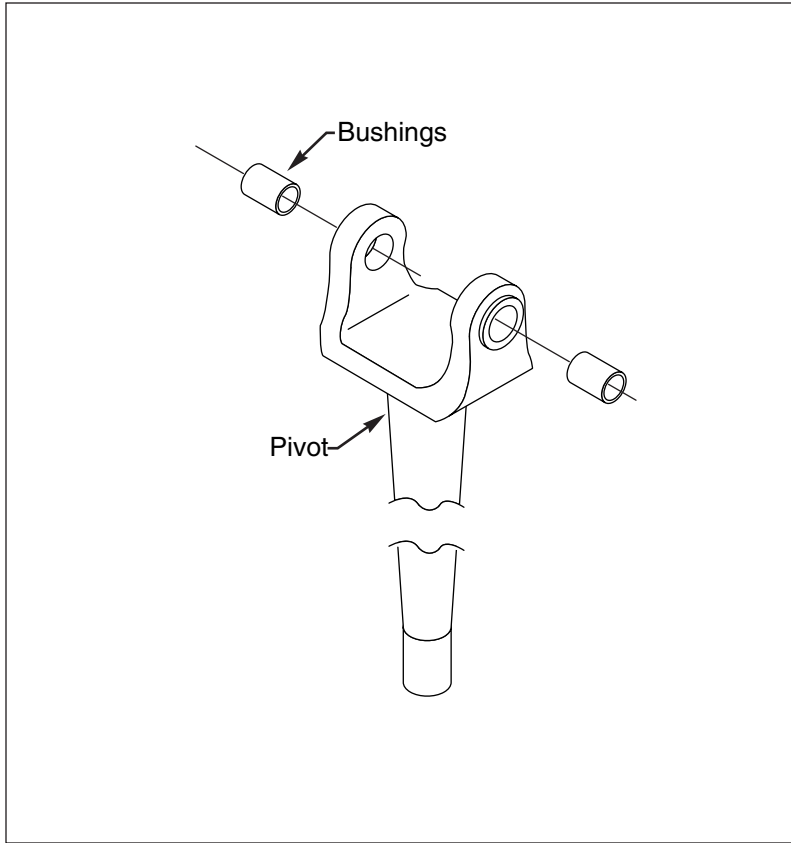

If any "clearance" is detected in the bushing of the Rock Slewing Pivot, the bushing should be checked immediately in order to prevent further damage.

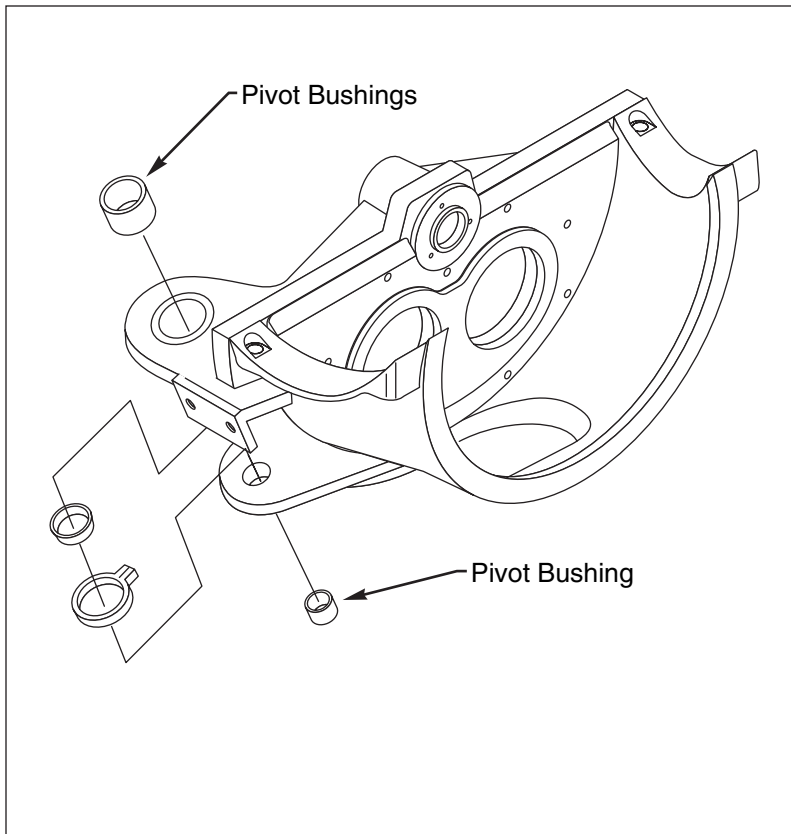

To check the bushing bore, drive out the thin, Teflon Coated Bushings or the Single Style Bushing.

Rock Valve

If the thin, teflon coated bushings are used, they can be replaced with new ones providing that the bore diameter is 80mm to a maximum of 80.20mm. A diameter over 80.20mm must be re-worked on a boring machine and bored to 90mm and the new style solid steel bushing* pressed in.

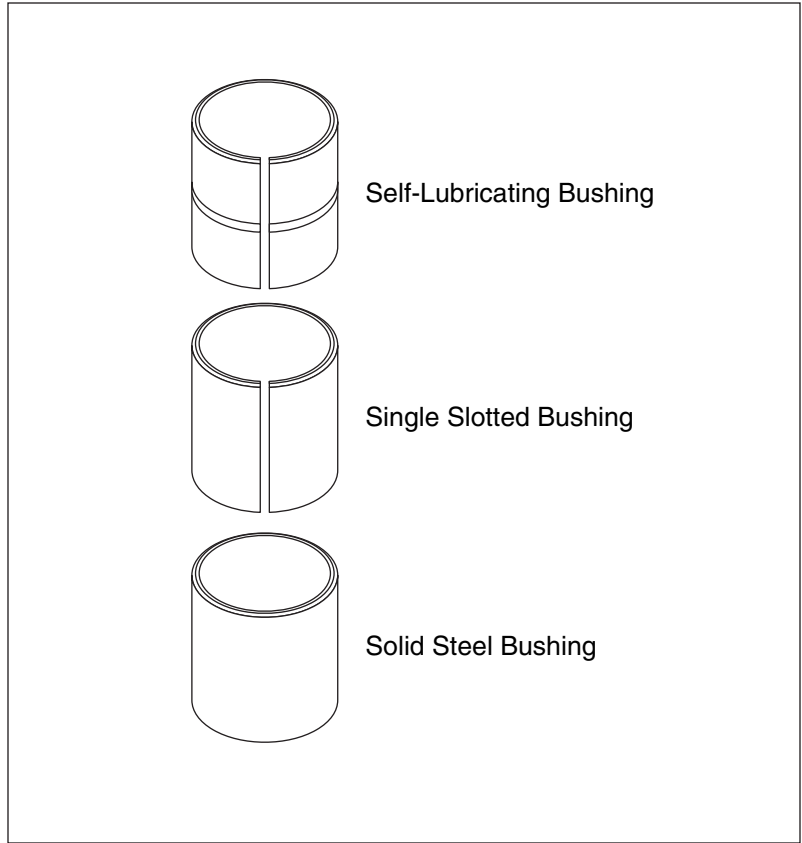

If the single slotted bushing* is used, the bore diameter is 90mm to a maximum of 90.20mm. A diameter of over 90.20mm can be repaired by the use of a repair kit (Part no. 10063611).

NOTE: The single slotted bushing is no longer available, but it has been replaced with a solid steel bushing with the same part number.

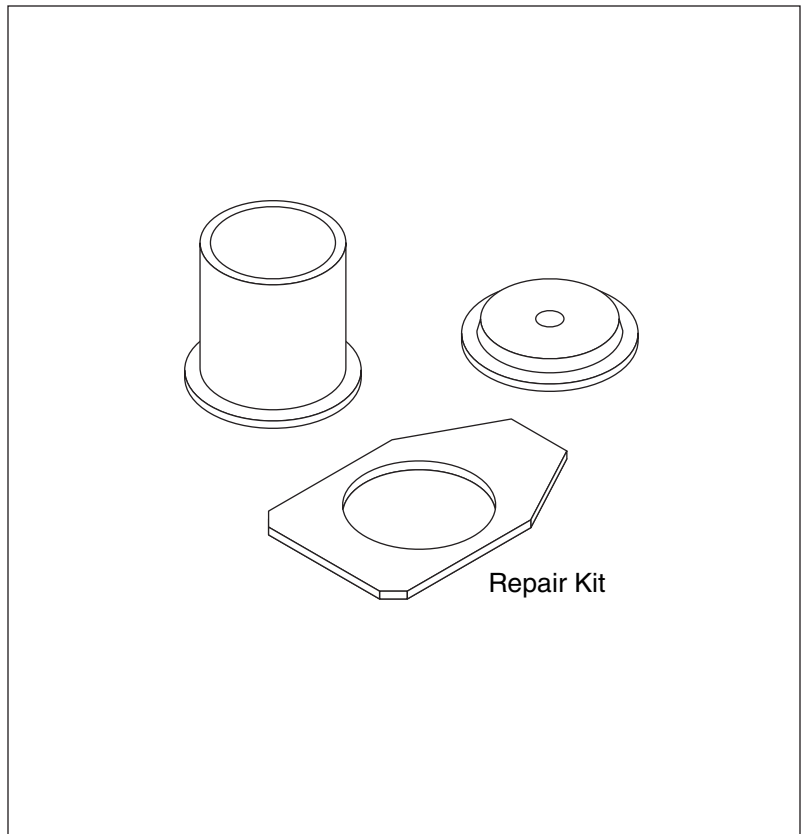

E-Rock

Additional Mounting Instructions for E-Rock Assembly

The E-rock is generally assembled by the same procedure as any other standard M-Rock. Only the Rock-Extension and a Counter Nut have been added. The Back-up ring will act as an axial bearing if the Counter-Nut is in place and has been directly adjusted.

Rock-Extension pre assembly:

1. Place the pivot shaft onto the rock and push it against the “stop” before tightening the screws.
2. Push the Rock-Extension supplied with O-rings over the pivot shaft and into the Rock.
3. Extension and Rock are held together by two screws.
4. Protection-Ring is placed inside the Extension and spot welded at four places around the circumference.

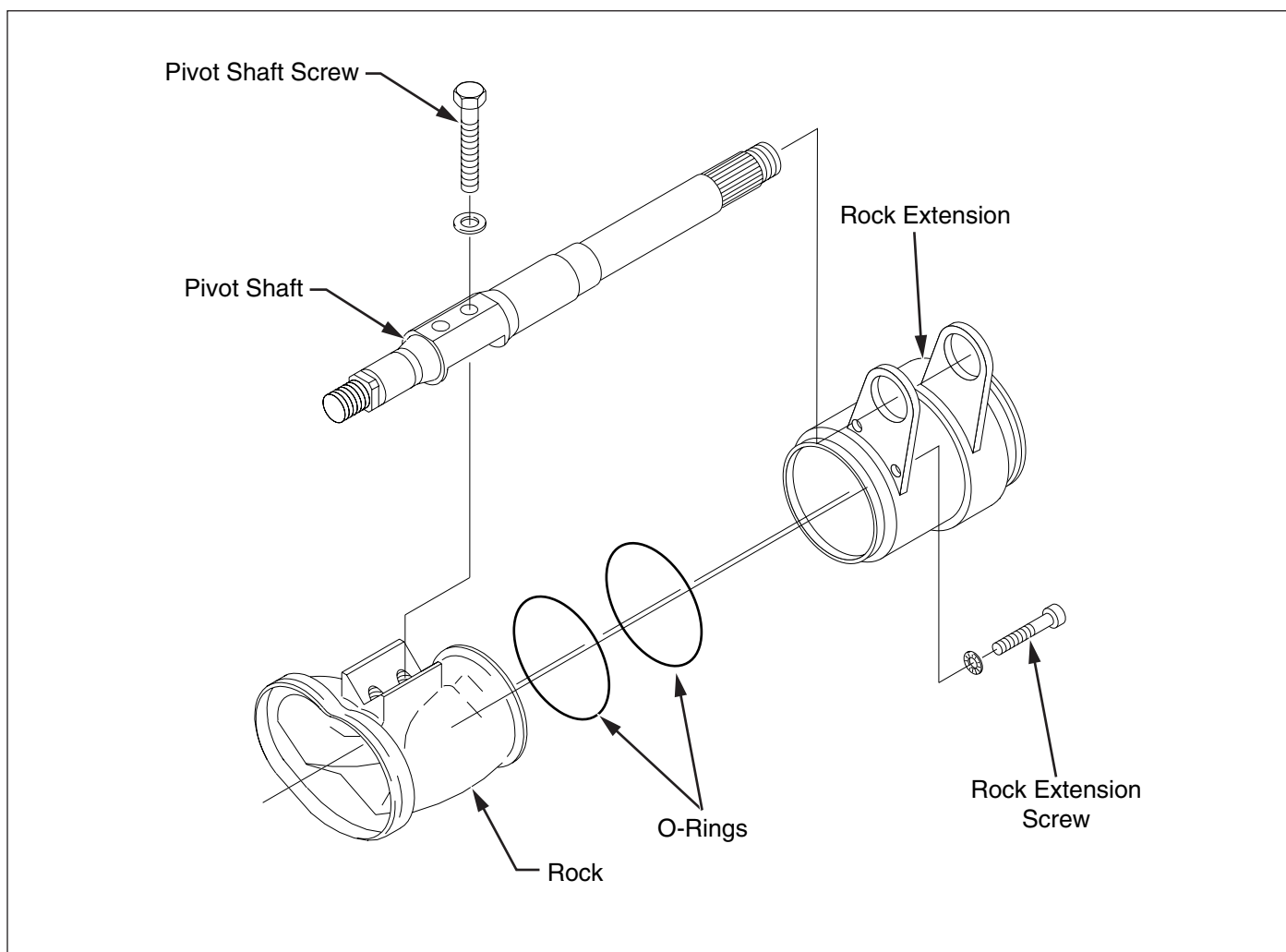

Rock Valve

Mounting of E-Rock-Valve and Cover

The pre assembled E-Rock-Valve (supplied with kidney seal and cutting ring assembly) is pushed into the Housing till the cutting rings hit the wear insert (spectacle plate). The end-cover will then compress the E-Rock-Valve assembly and the swivel shaft will be ready to be fixed by the Adjusting nut and Locking-Ring by the following procedure:

1. Place the Locking-Ring onto the square section at the shaft end.
2. Screw on the Adjusting-Nut till it hits the Locking-Ring and make up **HAND TIGHT**.
3. Turn the Adjusting-Nut clockwise only till the next possible hole of the Locking-Ring is reached to place the Locking Screw for securing the Adjustment-Nut.

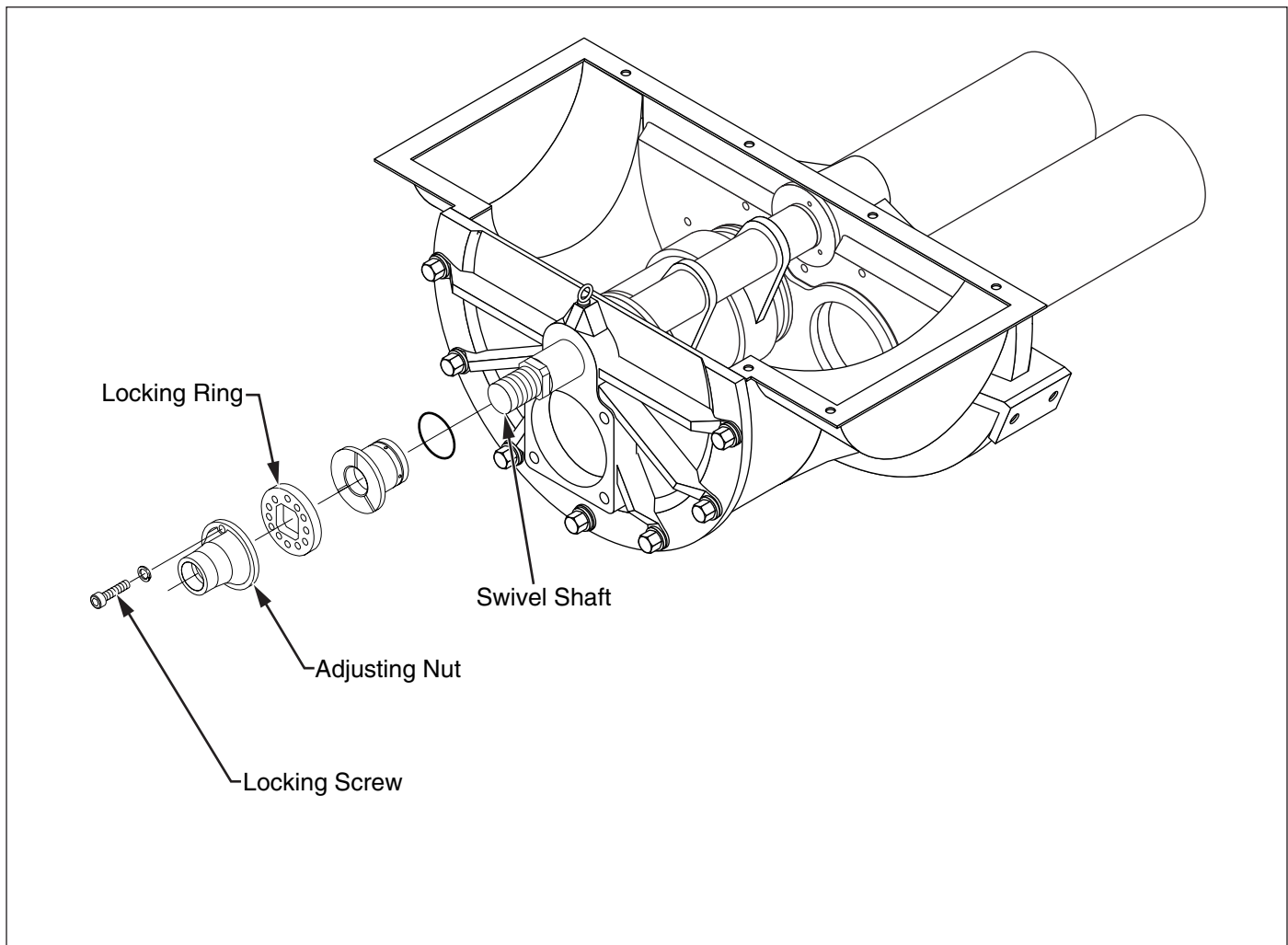

Placing the Counter-Nut at the lever side:

Only the E-Rock Valve requires an additional Counter-Nut to compensate for internal thrust forces when the system is in operation. The Counter-Nut can only be adjusted after the swivel drive is completely assembled. The Counter-Nut has a pitch of 2 mm.

1. Place the Ring and Lever supplied with the O-rings onto the Swivel Shaft. The parts are in the right position if the marked points (at the face) are matching.
2. Insert Ring into the Lever and watch out for the O-ring.
3. Screw on the Counter-Nut till it hits the Ring and make it hand tight.
4. Screw back the Counter-Nut by 1/4 turn and measure the gap. (approx. 0.5mm).
5. Secure the Counter-Nut by it's 3 worm screws.
6. Place the Cover over the Counter-Nut and secure with Bolt. Don't forget the O-Ring.

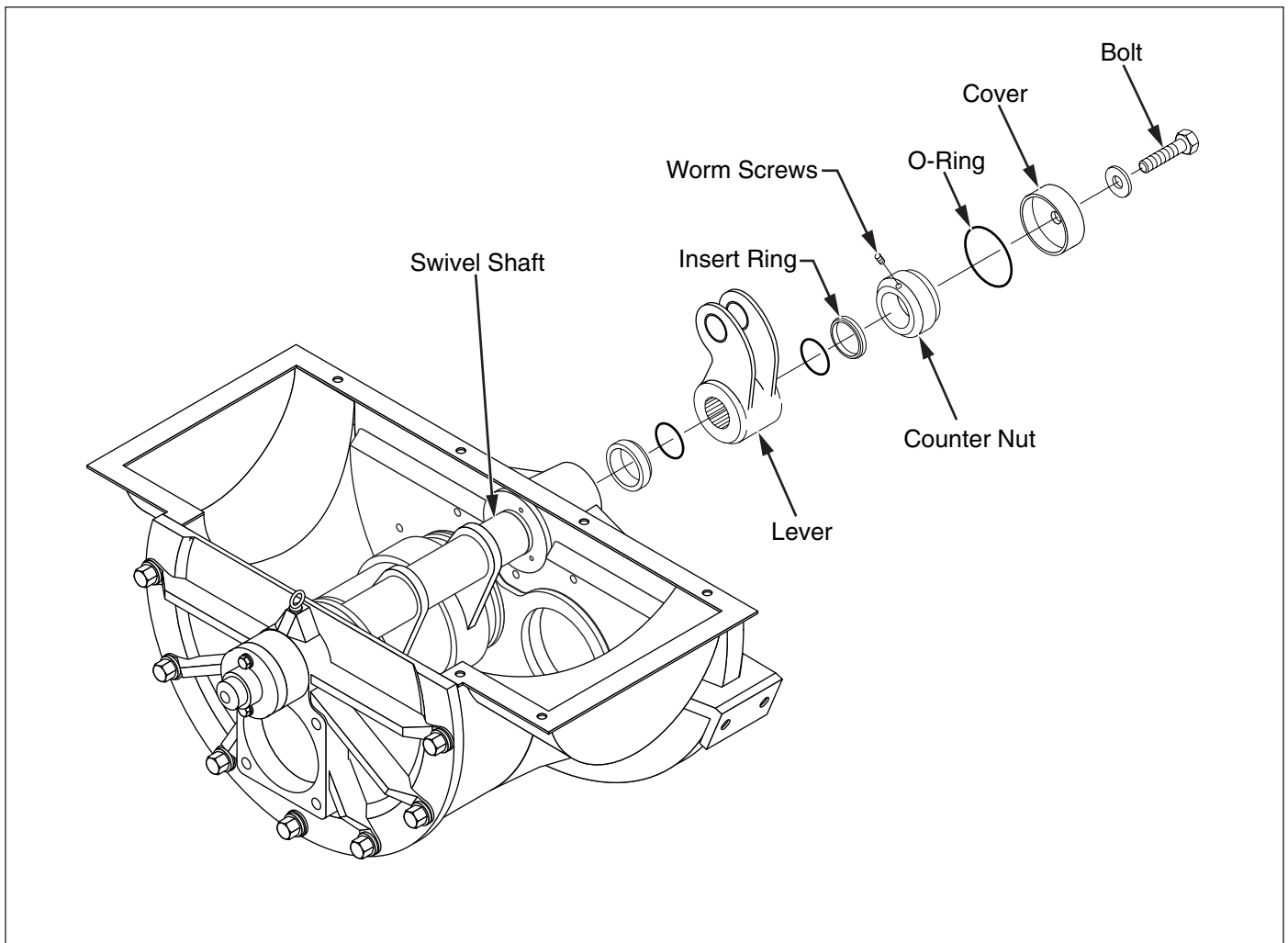

Rock Valve

Rock Slewing Cylinder

Pos	Qty.	Description	Part No.
1	1	SCREW DIN 908 R 3/8", 5.8	10001767
2	1	SEALING RING DIN 7603 A 17 X 21 CU	10003956
3	8	NUT DIN 6915 M 20, 10	10001232
4	8	DISC DIN 6916 M 21 C.45	10001509
5	1	PIPE PROTECTION	10017554
6	1	O-RING 56 X 4	10000749
7	1	CYLINDER HEAD	10017555
8	2	BALL STEEL	10006002
9	2	SPRING BOLT EV 105-0199	10017561
10	2	SPRING PRESSURE	10013054
11	2	SEALING RING DIN 7603 A 21 X 26 CU	10004056
12	2	VALVE PLUG EV 105-006C	10017562
13	2	O-RING 72 X 4	10000933
14	2	BACK-RING PTFE 80/73.6 X 1.5	10016238
15	1	CYLINDER PIPE	10017557
16	1	SLEWING PIVOT	10118218
17	2	BUSHING MB 3530	10006726

Pos	Qty.	Description	Part No.
18	2	BOLT	10058467
19	2	GREASE NIPPLE DIN 71412 CM 10 X 1, 5.8	10007884
20	2	SCREW DIN 933 M 10 X 20, 8.8	10001855
21	1	CYLINDER BEARING	10058466
22	2	RING SAFETY 68 X 2.5 DIN 472	10016233
23	1	ROD EYE	10017560
24	1	BEARING ARTICULATED GE 45 DO-2 RS	10019455
25	1	NUT HEX DIN 934 M 42 X 3 8	10017021
26	1	SCRAPER 45 X 44 X 7 P 6-45	10006804
27	1	RING TENSION	10017559
28	1	ROD SEALING R 32510055 45 X 60 X 11	10016236
29	1	CYLINDER HEAD	10094649
30	1	PISTON ROD	10017556
31	4	ANCHOR SCREW 20 X 570 M20 X 40 10.9	10016797
32	2	GUIDE BAND 9287 - 076.519	10016234
33	1	PISTON SEALING OMK - 5 - 80	10016235
34	1	SEAL KIT FOR SLEWING CYLINDER	10064756

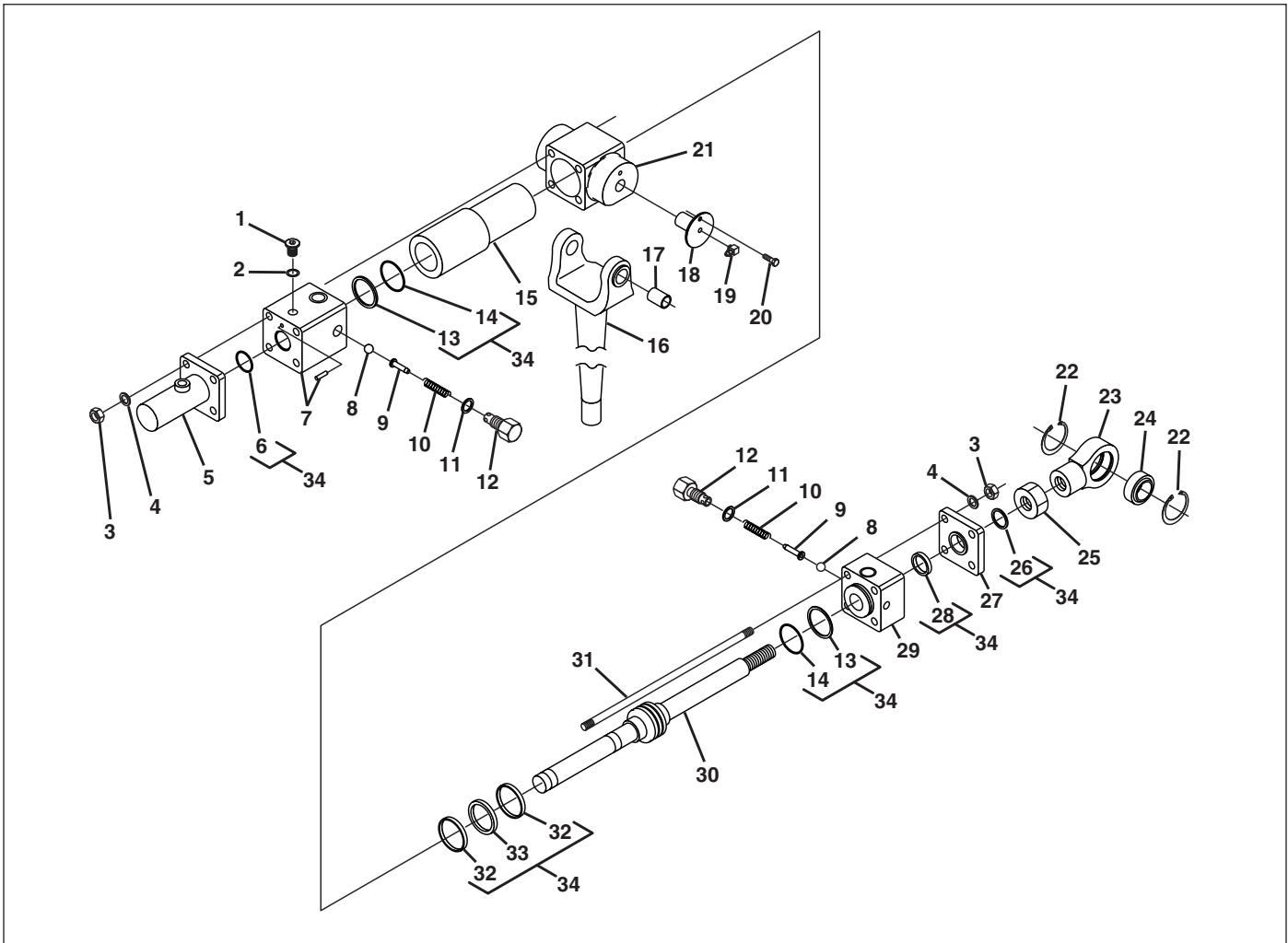

Welding Procedures-SAIE 5312

	<p>SAIE STANDARD</p>	No. : SAIE - 5312
		Date : 12-10-92 Rev :
Subject: WELDING PROCEDURES - ROCK VALVE HOUSING		By : TA
		Sheet : 1 of 1

For general welding on the rock valve housing, Schwing Germany recommends a UTPO68HH DIN 1736, S-NiCr 19 Nb, material number 2.4648. An equivalent American electrode must have the following physical and chemical properties:

<u>Alloy by % Weight</u>	<u>Permissible Additives</u>
Ni - at least 67	C - 0.1%
Cr - 18.0 to 22.0	S - 0.015%
Mn - 2.0 to 6.0	Co - 0.1%
Nb - 1.5 to 3.0	Si - 1.0%
	Cu - 0.5%
	Ti - 0.5%
	Fe - 4.0%
	Mo - 2.0%
	other elements total - 0.5%

Melting range - approx. 1400° C (2550° F).
 Nb is Niobium and it can be replaced by Ta (Tantalum)

Preheat the electrodes for 2 to 3 hours at 250 to 300° C (480 to 570° F)

The electrode must be high Ni and Cr content and high elongation. For example, Huntington INCONEL #82 wire, (AWS-ERNICRS) and Huntington INCO weld A, for 1/8" (Schwing Part#30352281) or 3/32"(Schwing Part#30352282) electrode AWS-ENICRFE2 or equivalent.

The parts to be welded must be very clean. Preheat the area to be welded to 250 to 300° C (480 to 570° F). Incline the electrode slightly and weld with short arcing. To prevent final crater cracks, fill up the crater as well as possible and lift-off the arcing at the side. To prevent cracking, we recommend placement of the casting into a preheated oven and letting it cool from 600° F to room temperature over 12 hours. If an oven is not available in your city, you can try to let the weld cool slowly under an asbestos blanket, an aluminum cover, or sand.

Rock Valve

Rock Valve with Insert - Conversion

Procedure for converting older Rock Valves to accept removable pressure spring insert.

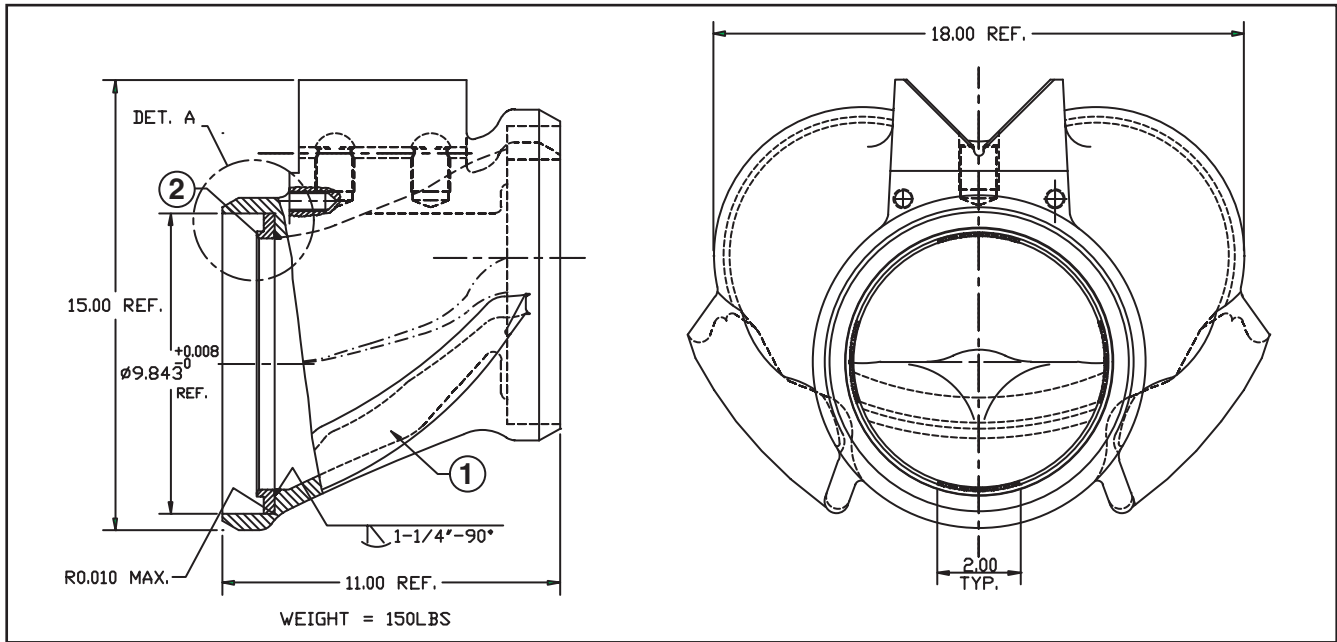

1. Weld per SAIE 5125 using E7108 and preheat to 200°F complete 360° of weld circle.
2. Addition of the insert requires a depth of 2.047. So if the Rock Valve has the standard depth 1.732 then it must be machined to 2.047 at the same 9.843 Dia.

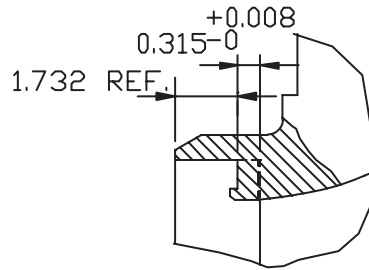

DETAIL A

3. To machine Rock Valve for insert use P/N 30348121 (Machine 0.315 deeper as shown in detail A).