

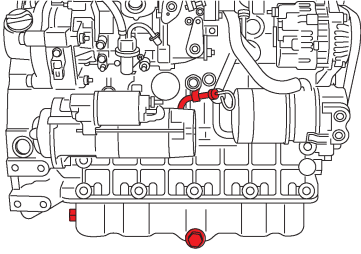
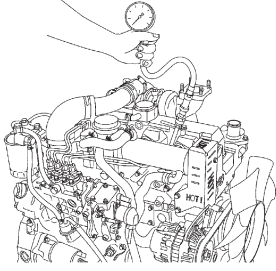
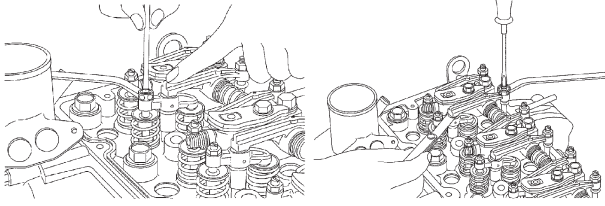
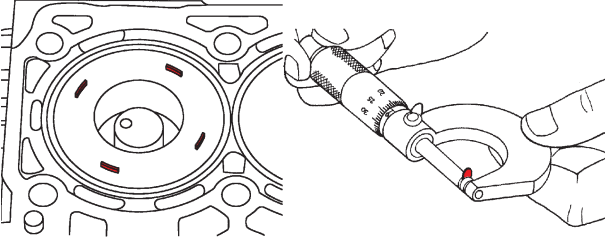
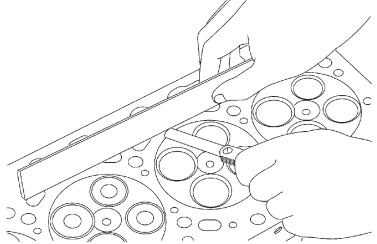
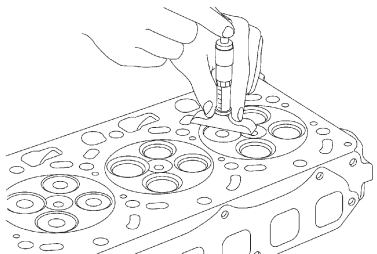
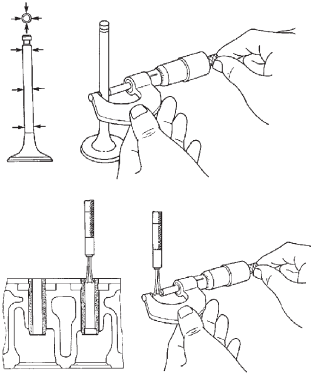
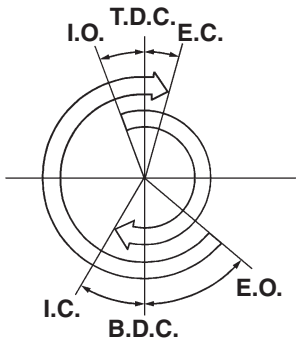

SERVICING SPECIFICATIONS

(1) ENGINE BODY

Item		Factory Specification	Allowable Limit
Lubricating oil capacity 	V2607-DI-E3B V2607-DI-T-E3B	10.2 L 2.69 U.S.gals.	—
	V3007-DI-T-E3B V3307-DI-T-E3B	11.2 L 2.96 U.S.gals.	—
Compression pressure 	V2607-DI-T-E3B	3.20 MPa / 250 min ⁻¹ (rpm) 32.6 kgf/cm ² / 250 min ⁻¹ (rpm) 464 psi / 250 min ⁻¹ (rpm)	2.20 MPa / 250 min ⁻¹ (rpm) 22.4 kgf/cm ² / 250 min ⁻¹ (rpm) 319 psi / 250 min ⁻¹ (rpm)
	V2607-DI-E3B V3007-DI-T-E3B V3307-DI-T-E3B	3.92 MPa / 250 min ⁻¹ (rpm) 40.0 kgf/cm ² / 250 min ⁻¹ (rpm) 569 psi / 250 min ⁻¹ (rpm)	2.90 MPa / 250 min ⁻¹ (rpm) 29.6 kgf/cm ² / 250 min ⁻¹ (rpm) 421 psi / 250 min ⁻¹ (rpm)
Valve clearance (When cold) 	All models	0.13 to 0.17 mm 0.0052 to 0.0068 in.	—
Top clearance 	All models	0.60 to 0.80 mm 0.024 to 0.031 in.	—
Cylinder head surface 	Flatness	All models	0.05 mm 0.002 in.

Item			Factory Specification	Allowable Limit
Valve recessing 	Valve recessing (Intake and exhaust)	All models	0.65 to 0.85 mm (Recessing) 0.026 to 0.033 in. (Recessing)	1.20 mm (Recessing) 0.0472 in. (Recessing)
Valve stem to valve guide 	Clearance (Intake)	V2607-DI-E3B V2607-DI-T-E3B V3007-DI-T-E3B V3307-DI-T-E3B	0.030 to 0.057 mm 0.0012 to 0.0022 in. 0.055 to 0.085 mm 0.0022 to 0.0033 in.	0.10 mm 0.0039 in.
	Valve stem O.D. (Intake)	V2607-DI-E3B V2607-DI-T-E3B V3007-DI-T-E3B V3307-DI-T-E3B	5.968 to 5.980 mm 0.2350 to 0.2354 in. 6.960 to 6.975 mm 0.2741 to 0.2746 in.	—
	Valve guide I.D. (Intake)	V2607-DI-E3B V2607-DI-T-E3B V3007-DI-T-E3B V3307-DI-T-E3B	6.010 to 6.025 mm 0.2367 to 0.2372 in. 7.030 to 7.045 mm 0.2768 to 0.2773 in.	—
	Clearance (Exhaust)	V2607-DI-E3B V2607-DI-T-E3B V3007-DI-T-E3B V3307-DI-T-E3B	0.045 to 0.072 mm 0.0018 to 0.0028 in. 0.055 to 0.085 mm 0.0022 to 0.0033 in.	0.10 mm 0.0039 in.
	Valve stem O.D. (Exhaust)	V2607-DI-E3B V2607-DI-T-E3B V3007-DI-T-E3B V3307-DI-T-E3B	5.953 to 5.965 mm 0.2344 to 0.2348 in. 6.960 to 6.975 mm 0.2741 to 0.2746 in.	—
	Valve guide I.D. (Exhaust)	V2607-DI-E3B V2607-DI-T-E3B V3007-DI-T-E3B V3307-DI-T-E3B	6.010 to 6.025 mm 0.2367 to 0.2372 in. 7.030 to 7.045 mm 0.2768 to 0.2773 in.	—
Valve timing 	Open (Intake valve)	V2607-DI-T-E3B V2607-DI-E3B V3007-DI-T-E3B V3307-DI-T-E3B	0.21 rad before T.D.C. 12° before T.D.C. 0.24 rad before T.D.C. 14° before T.D.C.	—
	Close (Intake valve)	V2607-DI-T-E3B V2607-DI-E3B V3007-DI-T-E3B V3307-DI-T-E3B	0.77 rad after B.D.C. 44° after B.D.C. 0.70 rad after B.D.C. 40° after B.D.C.	—
	Open (Exhaust valve)	V2607-DI-T-E3B V2607-DI-E3B V3007-DI-T-E3B V3307-DI-T-E3B	0.86 rad before B.D.C. 49° before B.D.C. 0.87 rad before B.D.C. 50° before B.D.C.	—
	Close (Exhaust valve)	V2607-DI-T-E3B V2607-DI-E3B V3007-DI-T-E3B V3307-DI-T-E3B	0.30 rad after T.D.C. 17° after T.D.C. 0.24 rad after T.D.C. 14° after T.D.C.	—

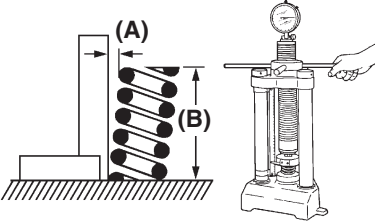
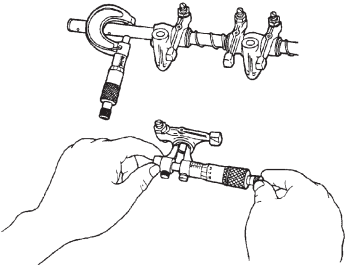
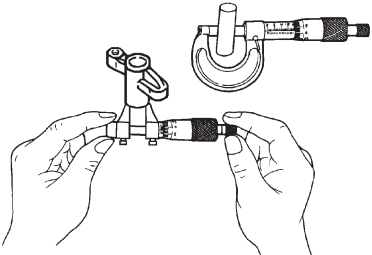
Item		Factory Specification	Allowable Limit	
Valve & valve seat 	Face angle (A) (Intake and exhaust)	All models 0.79 rad 45°	—	
	Seat angle (B) (Intake and exhaust)	All models 0.79 rad 45°	—	
	Seat width (C) (Intake and exhaust)	All models 3.3 to 3.6 mm 0.13 to 0.14 in.	—	
Valve spring 	Tilt (A) (Intake and exhaust)	All models —	1.0 mm 0.039 in.	
	Free length (B) (Intake and exhaust)	V2607-DI-E3B V2607-DI-T-E3B	35.4 to 35.9 mm 1.40 to 1.41 in.	34.9 mm 1.37 in.
		V3007-DI-T-E3B V3307-DI-T-E3B	35.1 to 35.6 mm 1.39 to 1.40 in.	34.6 mm 1.36 in.
	Setting load / Setting length (Intake and exhaust)	V2607-DI-E3B V2607-DI-T-E3B	60.8 N / 29.7 mm 6.20 kgf / 29.7 mm 13.7 lbf / 1.17 in.	45.9 N / 29.7 mm 4.68 kgf / 29.7mm 10.3 lbf / 1.17 in.
V3007-DI-T-E3B V3307-DI-T-E3B		63.5 N / 31.5 mm 6.48 kgf / 31.5 mm 14.3 lbf / 1.24 in.	45.9 N / 31.5 mm 4.68 kgf / 31.5 mm 10.3 lbf / 1.24 in.	
Rocker arm shaft to rocker arm 	Oil clearance	All models 0.016 to 0.045 mm 0.00063 to 0.0017 in.	0.15 mm 0.0059 in.	
	Rocker arm shaft O.D.	V2607-DI-E3B V2607-DI-T-E3B	13.973 to 13.984 mm 0.55012 to 0.55055 in.	—
		V3007-DI-T-E3B V3307-DI-T-E3B	14.973 to 14.984 mm 0.58949 to 0.58992 in.	—
	Rocker arm I.D.	V2607-DI-E3B V2607-DI-T-E3B	14.000 to 14.018 mm 0.55119 to 0.55188 in.	—
		V3007-DI-T-E3B V3307-DI-T-E3B	15.000 to 15.018 mm 0.59056 to 0.59125 in.	—
Valve bridge shaft to valve bridge arm 	Oil clearance	V2607-DI-E3B V2607-DI-T-E3B	0.018 to 0.057 mm 0.00071 to 0.0022 in.	0.15 mm 0.0059 in.
		V3007-DI-T-E3B V3307-DI-T-E3B	0.018 to 0.042 mm 0.00071 to 0.0016 in.	0.15 mm 0.0059 in.
	Valve bridge shaft O.D.	V2607-DI-E3B V2607-DI-T-E3B	8.023 to 8.032 mm 0.3159 to 0.3162 in.	—
		V3007-DI-T-E3B V3307-DI-T-E3B	9.023 to 9.032 mm 0.3553 to 0.3555 in.	—
	Valve bridge arm I.D.	V2607-DI-E3B V2607-DI-T-E3B	8.050 to 8.080 mm 0.3170 to 0.3181 in.	—
		V3007-DI-T-E3B V3307-DI-T-E3B	9.050 to 9.065 mm 0.3563 to 0.3568 in.	—

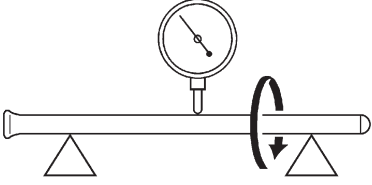
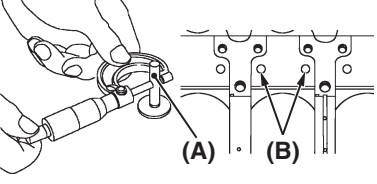
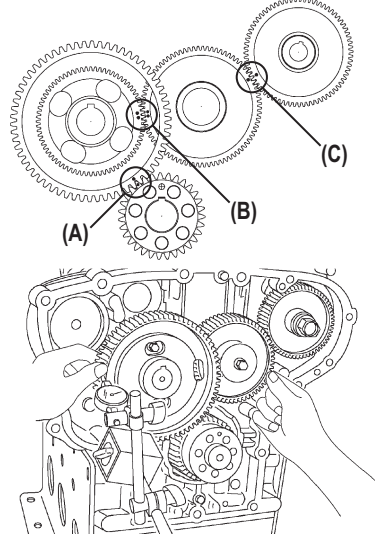
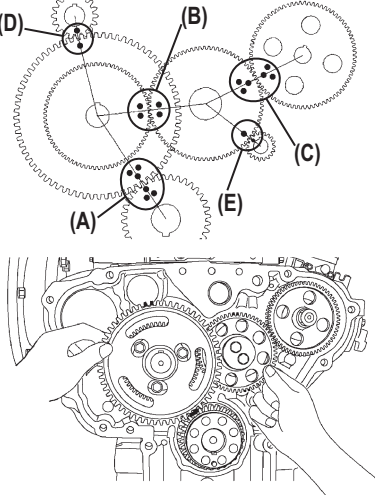
Item			Factory Specification	Allowable Limit
Push rod 	Alignment	All models	—	0.25 mm 0.0098 in.
Tappet to tappet bore 	Oil clearance	All models	0.020 to 0.050 mm 0.00079 to 0.0019 in.	0.07 mm 0.003 in.
	Tappet O.D. (A)	All models	9.965 to 9.980 mm 0.3924 to 0.3929 in.	—
	Tappet bore I.D. (B)	All models	10.000 to 10.015 mm 0.39370 to 0.39429 in.	—
Timing gear [V2607-DI-E3B / V2607-DI-T-E3B] 	Backlash (Crank gear to cam gear) (A)	V2607-DI-E3B V2607-DI-T-E3B	0.0400 to 0.137 mm 0.00158 to 0.00539 in.	0.22 mm 0.0087 in.
		V3007-DI-T-E3B V3307-DI-T-E3B	0.0410 to 0.139 mm 0.00162 to 0.00547 in.	0.22 mm 0.0087 in.
	Backlash (Cam gear to idle gear) (B)	V2607-DI-E3B V2607-DI-T-E3B	0.0460 to 0.136 mm 0.00182 to 0.00535 in.	0.22 mm 0.0087 in.
		V3007-DI-T-E3B V3307-DI-T-E3B	0.0410 to 0.134 mm 0.00162 to 0.00527 in.	0.22 mm 0.0087 in.
[V3007-DI-T-E3B / V3307-DI-T-E3B] 	Backlash (Idle gear to injection pump gear) (C)	V2607-DI-E3B V2607-DI-T-E3B	0.0460 to 0.136 mm 0.00182 to 0.00535 in.	0.22 mm 0.0087 in.
		V3007-DI-T-E3B V3307-DI-T-E3B	0.0410 to 0.134 mm 0.00162 to 0.00527 in.	0.22 mm 0.0087 in.
	Backlash (Cam gear to balancer 1 gear) (D)	V3007-DI-T-E3B V3307-DI-T-E3B Balancer model only	0.0410 to 0.134 mm 0.00162 to 0.00527 in.	0.22 mm 0.0087 in.
	Backlash (Idle gear to balancer 2 gear) (E)	V3007-DI-T-E3B V3307-DI-T-E3B Balancer model only	0.0410 to 0.129 mm 0.00162 to 0.00507 in.	0.22 mm 0.0087 in.

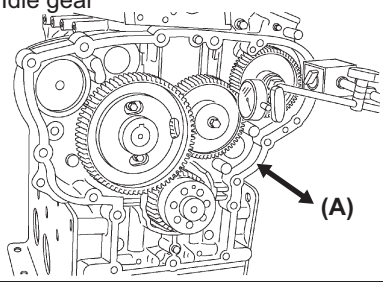
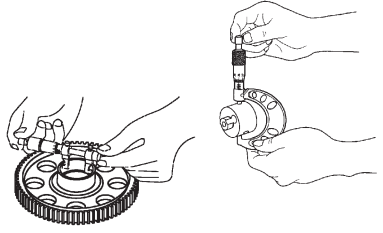
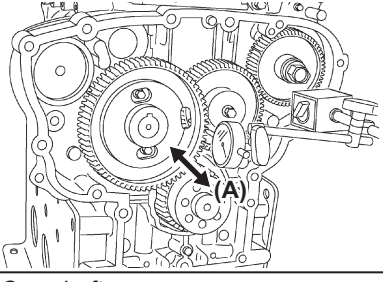
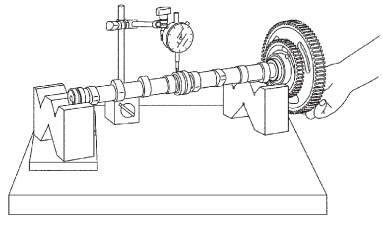
Item		Factory Specification	Allowable Limit	
Idle gear 	Side clearance (A)	V2607-DI-E3B V2607-DI-T-E3B	0.050 to 0.20 mm 0.0020 to 0.0078 in.	0.90 mm 0.035 in.
		V3007-DI-T-E3B V3307-DI-T-E3B	0.15 to 0.25 mm 0.0059 to 0.0098 in.	0.90 mm 0.035 in.
Idle gear shaft to idle gear bushing 	Oil clearance	V2607-DI-E3B V2607-DI-T-E3B	0.025 to 0.096 mm 0.00099 to 0.0037 in.	0.10 mm 0.0039 in.
		V3007-DI-T-E3B V3307-DI-T-E3B	0.050 to 0.091 mm 0.0020 to 0.0035 in.	0.10 mm 0.0039 in.
	Idle gear shaft O.D.	V2607-DI-E3B V2607-DI-T-E3B	34.959 to 34.975 mm 1.3764 to 1.3769 in.	—
		V3007-DI-T-E3B V3307-DI-T-E3B	34.959 to 34.975 mm 1.3764 to 1.3769 in.	—
	Idle gear bushing I.D.	V2607-DI-E3B V2607-DI-T-E3B	35.000 to 35.055 mm 1.3780 to 1.3801 in.	—
		V3007-DI-T-E3B V3307-DI-T-E3B	35.025 to 35.050 mm 1.3790 to 1.3799 in.	—
Camshaft 	Side clearance (A)	All models	—	0.10 mm 0.0039 in.
	Camshaft 	Alignment	All models	—

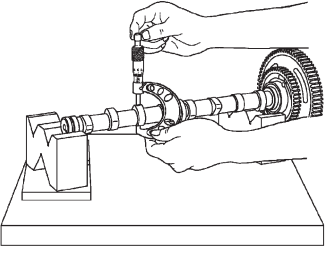
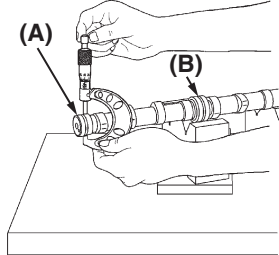
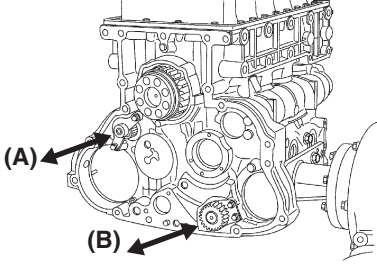
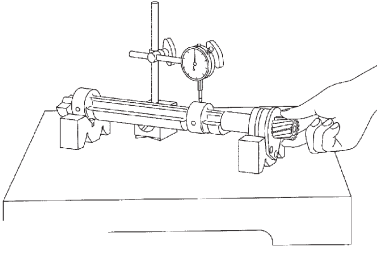
Item		Factory Specification	Allowable Limit	
Cam 	Height (Intake)	V2607-DI-E3B	32.70 mm 1.287 in.	32.20 mm 1.268 in.
		V2607-DI-T-E3B	32.60 mm 1.283 in.	32.10 mm 1.264 in.
		V3007-DI-T-E3B V3307-DI-T-E3B	37.50 mm 1.476 in.	37.00 mm 1.457 in.
	Height (Exhaust)	V2607-DI-E3B	33.20mm 1.307 in.	32.70 mm 1.287 in.
		V2607-DI-T-E3B	33.00 mm 1.299 in.	32.50 mm 1.280 in.
		V3007-DI-T-E3B V3307-DI-T-E3B	37.90 mm 1.492 in.	37.40 mm 1.472 in.
Camshaft journal to cylinder block bore 	Oil clearance	All models	0.050 to 0.091 mm 0.0020 to 0.0035 in.	0.15 mm 0.0059 in.
	Camshaft journal 1 O.D. (A)	All models	34.934 to 34.950 mm 1.3754 to 1.3759 in.	—
	Camshaft journal 2 O.D. (B)	V2607-DI-E3B V2607-DI-T-E3B	41.934 to 41.950 mm 1.6510 to 1.6515 in.	—
		V3007-DI-T-E3B V3307-DI-T-E3B	43.934 to 43.950 mm 1.7297 to 1.7303 in.	—
	Cylinder block bore 1 I.D.	All models	35.000 to 35.025 mm 1.3780 to 1.3789 in.	—
	Cylinder block bore 2 I.D.	V2607-DI-E3B V2607-DI-T-E3B	42.000 to 42.025 mm 1.6536 to 1.6545 in.	—
V3007-DI-T-E3B V3307-DI-T-E3B		44.000 to 44.025 mm 1.7323 to 1.7332 in.	—	
Balancer shaft 	Side clearance (Balancer shaft 1 (B))	V3007-DI-T-E3B V3307-DI-T-E3B Balancer model only	0.070 to 0.22 mm 0.0028 to 0.0086 in.	0.30 mm 0.012 in.
	Side clearance (Balancer shaft 2 (A))	V3007-DI-T-E3B V3307-DI-T-E3B Balancer model only	0.070 to 0.32 mm 0.0028 to 0.012 in.	0.34 mm 0.013 in.
Balancer shaft 	Alignment (Balancer shaft 1 and balancer shaft 2)	V3007-DI-T-E3B V3307-DI-T-E3B Balancer model only	—	0.02 mm 0.0008 in.

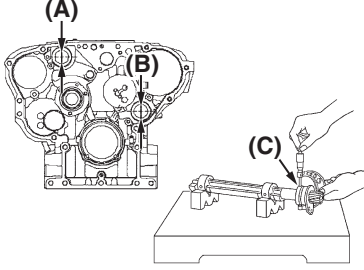
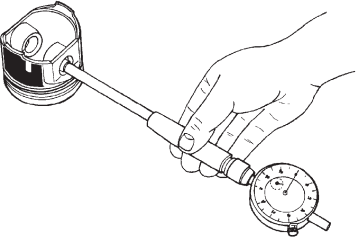
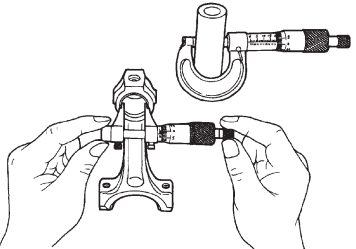
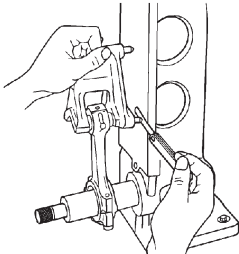
Item		Factory Specification	Allowable Limit	
<p>Balancer shaft journal to balancer shaft bearing</p> 	Oil clearance (Balancer shaft 1)	V3007-DI-T-E3B V3307-DI-T-E3B Balancer model only	0.0600 to 0.146 mm 0.0237 to 0.00574 in.	0.20 mm 0.0079 in.
	Oil clearance (Balancer shaft 2)	V3007-DI-T-E3B V3307-DI-T-E3B Balancer model only	0.0500 to 0.136 mm 0.00197 to 0.00535 in.	0.20 mm 0.0079 in.
	Balancer shaft journal O.D. (Balancer shaft 1 (C))	V3007-DI-T-E3B V3307-DI-T-E3B Balancer model only	48.934 to 48.950 mm 1.9266 to 1.9271 in.	—
	Balancer shaft journal O.D. (Balancer shaft 2 (C))	V3007-DI-T-E3B V3307-DI-T-E3B Balancer model only	48.934 to 48.950 mm 1.9266 to 1.9271 in.	—
	Balancer shaft bearing I.D. (Balancer shaft 1 (A))	V3007-DI-T-E3B V3307-DI-T-E3B Balancer model only	49.010 to 49.080 mm 1.9296 to 1.9322 in.	—
	Balancer shaft bearing I.D. (Balancer shaft 2 (B))	V3007-DI-T-E3B V3307-DI-T-E3B Balancer model only	49.000 to 49.070 mm 1.9292 to 1.9318 in.	—
<p>Piston pin bore</p> 	Piston pin bore I.D.	V2607-DI-E3B V2607-DI-T-E3B	26.000 to 26.013 mm 1.0237 to 1.0241 in.	26.05 mm 1.026 in.
		V3007-DI-T-E3B V3307-DI-T-E3B	28.000 to 28.013 mm 1.1024 to 1.1028 in.	28.05 mm 1.104 in.
<p>Piston pin to small end bushing</p> 	Oil clearance	V2607-DI-E3B V2607-DI-T-E3B	0.014 to 0.034 mm 0.00056 to 0.0013 in.	0.15 mm 0.0059 in.
		V3007-DI-T-E3B V3307-DI-T-E3B	0.020 to 0.040 mm 0.00079 to 0.0015 in.	0.15 mm 0.0059 in.
	Piston pin O.D.	V2607-DI-E3B V2607-DI-T-E3B	26.006 to 26.011 mm 1.0239 to 1.0240 in.	—
		V3007-DI-T-E3B V3307-DI-T-E3B	28.006 to 28.011 mm 1.1026 to 1.1027 in.	—
	Small end bushing I.D.	V2607-DI-E3B V2607-DI-T-E3B	26.025 to 26.040 mm 1.0246 to 1.0252 in.	—
		V3007-DI-T-E3B V3307-DI-T-E3B	28.031 to 28.046 mm 1.1036 to 1.1041 in.	—
<p>Connecting rod</p> 	Alignment	All models	—	0.05 mm 0.002 in.

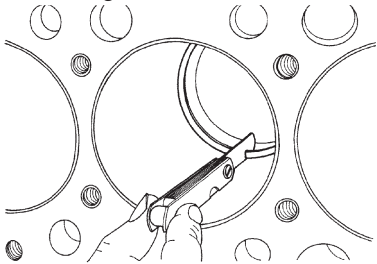
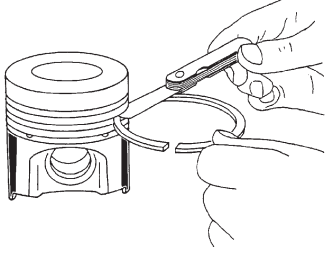
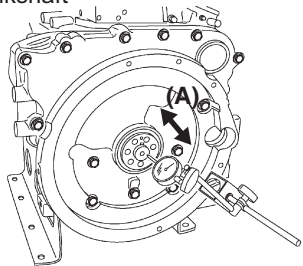
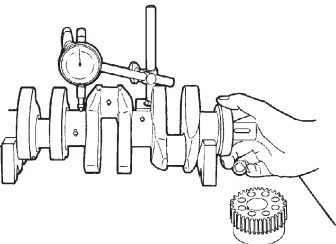
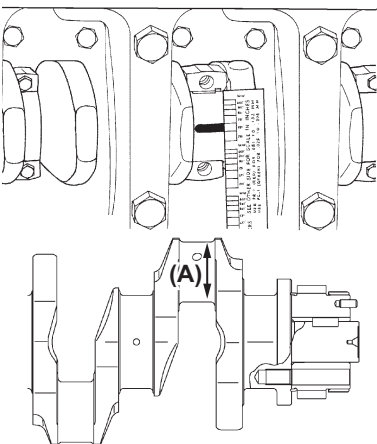
Item		Factory Specification	Allowable Limit	
	Ring gap (Top ring)	V2607-DI-E3B V2607-DI-T-E3B	0.20 to 0.35 mm 0.0079 to 0.013 in.	1.25 mm 0.0492 in.
		V3007-DI-T-E3B V3307-DI-T-E3B	0.25 to 0.40 mm 0.0099 to 0.015 in.	1.25 mm 0.0492 in.
	Ring gap (Second ring)	All models	0.30 to 0.45 mm 0.012 to 0.017 in.	1.25 mm 0.0492 in.
	Ring gap (Oil ring)	All models	0.25 to 0.45 mm 0.0099 to 0.017 in.	1.25 mm 0.0492 in.
	Clearance (Top ring)	All models	0.050 to 0.090 mm 0.0020 to 0.0035 in.	0.15 mm 0.0059 in.
	Clearance (Second ring)	All models	0.090 to 0.12 mm 0.0035 to 0.0047 in.	0.20 mm 0.0079 in.
	Clearance (Oil ring)	All models	0.020 to 0.060 mm 0.00079 to 0.0023 in.	0.15 mm 0.0059 in.
	Side clearance (A)	All models	0.15 to 0.35 mm 0.0059 to 0.013 in.	0.50 mm 0.020 in.
	Alignment	All models	—	0.02 mm 0.0008 in.
	Oil clearance	V2607-DI-E3B V2607-DI-T-E3B	0.011 to 0.058 mm 0.00044 to 0.0022 in.	0.20 mm 0.0079 in.
		V3007-DI-T-E3B V3307-DI-T-E3B	0.017 to 0.048 mm 0.00067 to 0.0018 in.	0.20 mm 0.0079 in.
	Crankpin O.D. (A)	V2607-DI-E3B V2607-DI-T-E3B	46.980 to 46.991 mm 1.8496 to 1.8500 in.	—
		V3007-DI-T-E3B V3307-DI-T-E3B	49.980 to 49.991 mm 1.9678 to 1.9681 in.	—

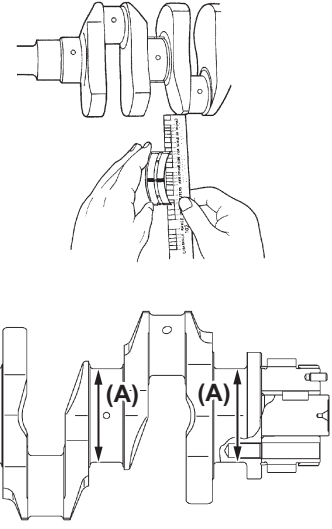
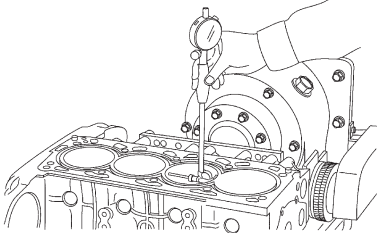
Item			Factory Specification	Allowable Limit
<p>Crankshaft journal to crankshaft bearing</p> 	Oil clearance	V2607-DI-E3B V2607-DI-T-E3B	0.030 to 0.051 mm 0.0012 to 0.0020 in.	0.20 mm 0.0079 in.
		V3007-DI-T-E3B V3307-DI-T-E3B	0.030 to 0.073 mm 0.0012 to 0.0028 in.	0.20 mm 0.0079 in.
	Crankshaft journal O.D. (A)	V2607-DI-E3B V2607-DI-T-E3B	72.977 to 72.990 mm 2.8732 to 2.8736 in.	—
		V3007-DI-T-E3B V3307-DI-T-E3B	79.977 to 79.990 mm 3.1487 to 3.1492 in.	—
<p>Cylinder</p> 	Bore I.D. (Standard size)	V2607-DI-E3B V2607-DI-T-E3B	87.000 to 87.022 mm 3.4252 to 3.4260 in.	87.15 mm 3.431 in.
		V3007-DI-T-E3B V3307-DI-T-E3B	94.000 to 94.022 mm 3.7008 to 3.7016 in.	94.15 mm 3.707 in.
	Bore I.D. (Oversize)	V2607-DI-E3B V2607-DI-T-E3B	87.250 to 87.272 mm 3.4350 to 3.4359 in.	87.40 mm 3.441 in.
		V3007-DI-T-E3B V3307-DI-T-E3B	94.500 to 94.522 mm 3.7205 to 3.7213 in.	94.65 mm 3.726 in.

(2) LUBRICATING SYSTEM

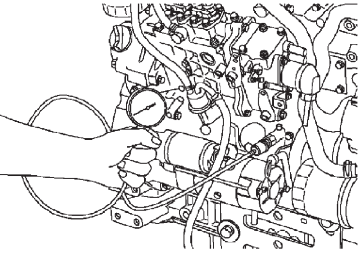
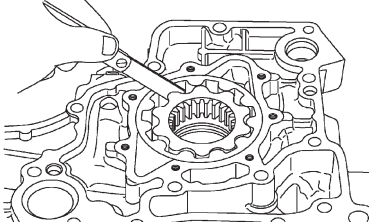
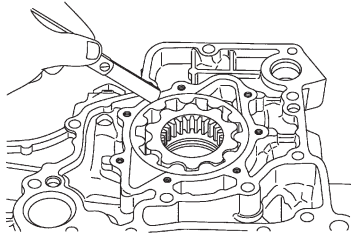
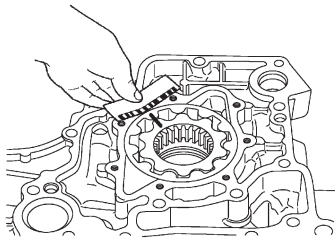
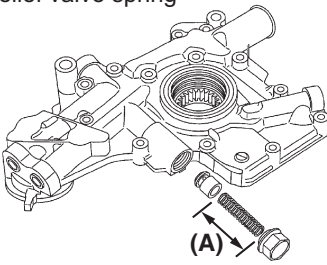
Item		Factory Specification	Allowable Limit
Engine oil pressure 	Engine oil pressure (At idle speed)	All models —	49 kPa 0.50 kgf/cm ² 7.1 psi
	Engine oil pressure (At rated speed)	All models 197 to 392 kPa 2.00 to 4.00 kgf/cm ² 28.5 to 56.8 psi	147 kPa 1.50 kgf/cm ² 21.3 psi
Inner rotor to outer rotor (Oil pump) 	Clearance	All models 0.030 to 0.090 mm 0.0012 to 0.0035 in.	0.30 mm 0.012 in.
Outer rotor to pump body (Oil pump) 	Clearance	All models 0.100 to 0.184 mm 0.00394 to 0.00724 in.	0.30 mm 0.012 in.
Inner rotor to cover (Oil pump) 	Clearance	All models 0.025 to 0.075 mm 0.00099 to 0.0029 in.	0.225 mm 0.00886 in.
Relief valve spring 	Free length (A)	All models 60.0 to 60.5 mm 2.37 to 2.38 in.	55.0 mm 2.17 in.

(3) COOLING SYSTEM

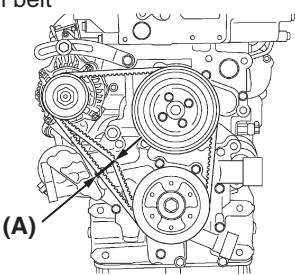
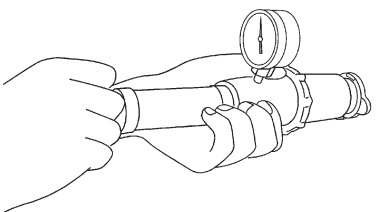
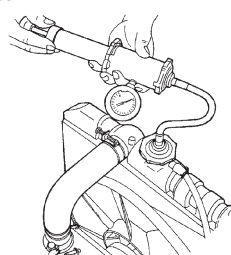
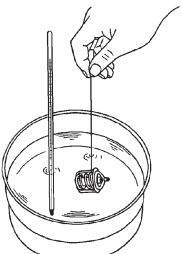
Item			Factory Specification	Allowable Limit
Fan belt 	Tension (A)	All models	10.0 to 12.0 mm / 98 N 0.394 to 0.472 in. / 98 N (10 kgf, 22 lbf)	—
Radiator cap 	Pressure falling time	All models	10 seconds or more 88 → 59 kPa 0.90 → 0.60 kgf/cm ² , 13 to → 8.5 psi	—
Radiator 	Water tightness	All models	No leak at specified pressure	—
Thermostat 	Valve opening temperature (At beginning)	V2607-DI-E3B V2607-DI-T-E3B	80 to 84 °C 176 to 183 °F	—
		V3007-DI-T-E3B V3307-DI-T-E3B	74.5 to 78.5 °C 166.1 to 173.3 °F	—
	Valve opening temperature (Opened completely)	V2607-DI-E3B V2607-DI-T-E3B	95 °C 203 °F	—
		V3007-DI-T-E3B V3307-DI-T-E3B	90 °C 194 °F	—

(4) FUEL SYSTEM

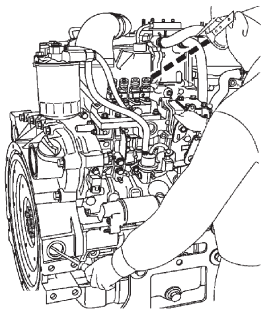
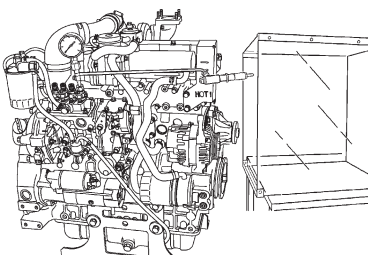
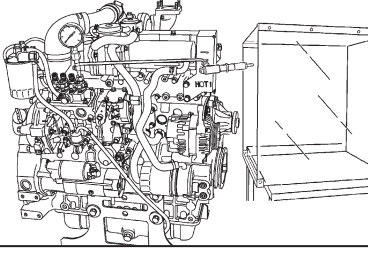
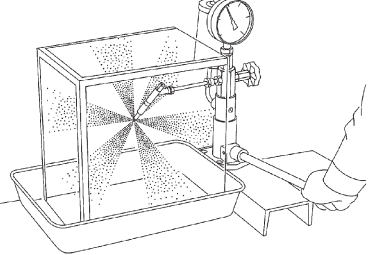
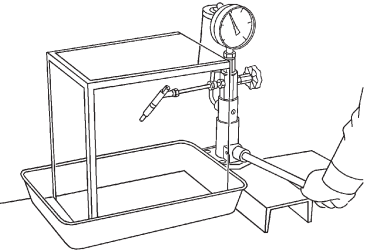
Item		Factory Specification	Allowable Limit	
	Injection timing	V2607-DI-E3B	0.027 to 0.052 rad before T.D.C. (1.5 ° to 3.0 ° before T.D.C.)	—
		V2607-DI-T-E3B (Serial No. : 8G0001 to 8V9999)	0.0087 rad before T.D.C. to 0.017 rad after T.D.C. (0.50 ° before T.D.C. to 1.0 ° after T.D.C.)	—
		V2607-DI-T-E3B (Serial No. : 8W0001 and above)	0.017 rad before T.D.C. to 0.0087 rad after T.D.C. (1.0 ° before T.D.C. to 0.50 ° after T.D.C.)	—
		V3007-DI-T-E3B	0.00261 rad before T.D.C. to 0.0235 rad after T.D.C. (0.150 ° before T.D.C. to 1.35 ° after T.D.C.)	—
		V3307-DI-T-E3B	0.00960 to 0.0357 rad after T.D.C. (0.550 to 2.05 ° after T.D.C.)	—
	Fuel tightness	All models	—	18.63 MPa 190.0 kgf/cm ² 2702 psi
	Fuel tightness	All models	10 seconds 18.63 → 17.66 MPa 190.0 → 180.0 kgf/cm ² 2702 → 2561 psi	5 seconds 18.63 → 17.66 MPa 190.0 → 180.0 kgf/cm ² 2702 → 2561 psi
	Injection pressure (1st stage)	V2607-DI-E3B V2607-DI-T-E3B	18.64 to 20.10 MPa 190.0 to 205.0 kgf/cm ² 2703 to 2915 psi	—
		V3007-DI-T-E3B V3307-DI-T-E3B	18.64 to 19.61 MPa 190.0 to 200.0 kgf/cm ² 2703 to 2844 psi	—
	Valve seat tightness	All models	No fuel leak at 16.67 MPa 170.0 kgf/cm ² 2418 psi	—

(5) ELECTRICAL SYSTEM

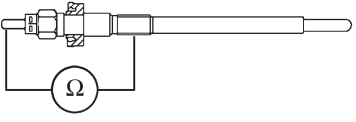
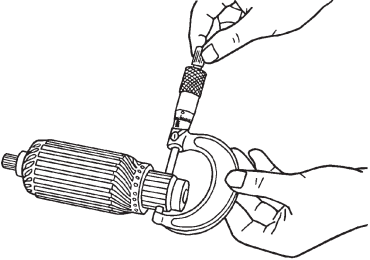
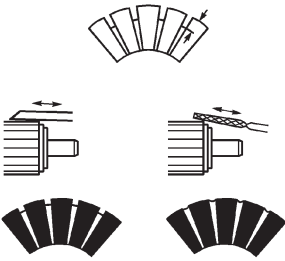
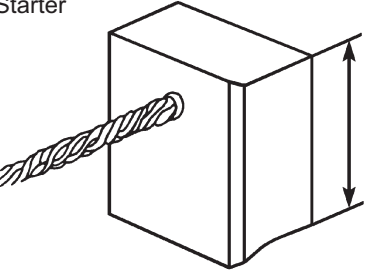
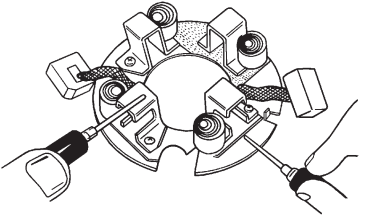
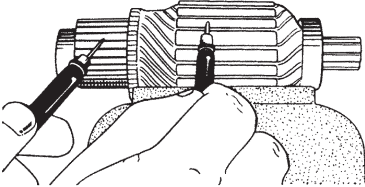
Item			Factory Specification	Allowable Limit
Glow plug 	Resistance	All models	Approx. 0.95 Ω	—
Starter 	Commutator O.D.	All models	32.0 mm 1.26 in.	31.4 mm 1.24 in.
Starter 	Mica under cut	All models	0.50 mm 0.020 in.	0.20 mm 0.0079 in.
Starter 	Brush length	All models	18.0 mm 0.709 in.	11.0 mm 0.433 in.
Starter 	Brush holder resistance (Brush holder - Holder support)	All models	Infinity	—
Starter 	Armature coil resistance (Commutator - Armature coil core)	All models	Infinity	—

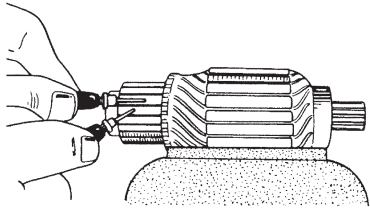
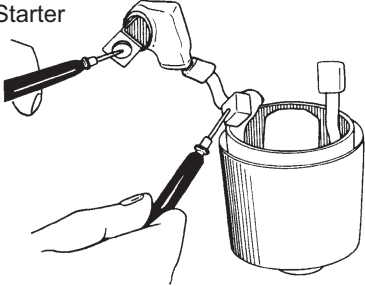
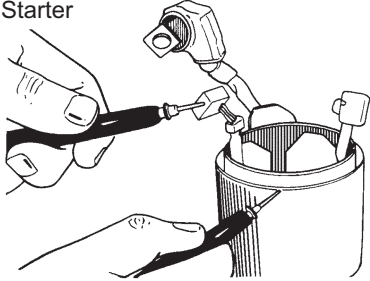
Item		Factory Specification	Allowable Limit
Starter 	Armature coil resistance (Segment - Segment)	All models 0 Ω	—
Starter 	Field coil resistance (Lead - Brush)	All models 0 Ω	—
Starter 	Field coil resistance (Brush - Yoke)	All models Infinity	—

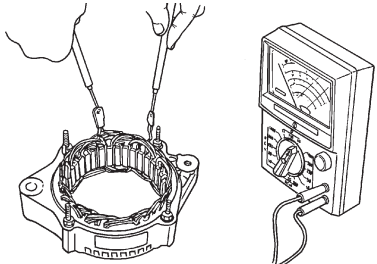
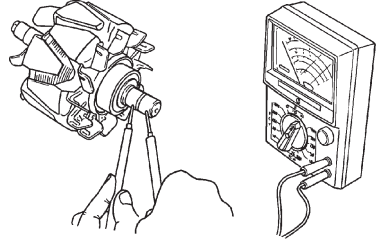
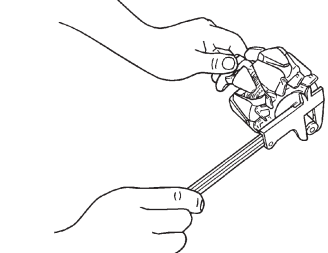
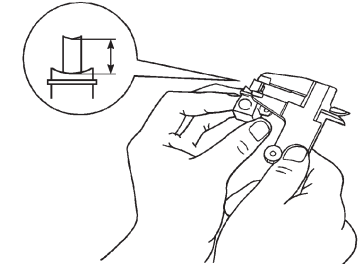
Item			Factory Specification	Allowable Limit
Alternator 	Stator resistance	All models	Less than 1.0 Ω	—
Alternator 	Rotor resistance	All models	2.8 to 3.3 Ω	—
Alternator 	Slip ring O.D.	All models	22.7 mm 0.894 in.	22.1 mm 0.870 in.
Alternator 	Brush length	All models	18.5 mm 0.728 in.	5.0 mm 0.20 in.

TIGHTENING TORQUES

(1) Special Tightening Torques

For "*" marked screws, bolts and nuts on under table, apply engine oil to their threads and seats before tightening.

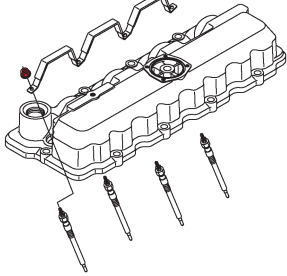
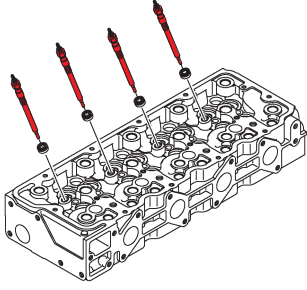
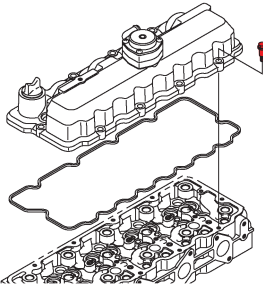
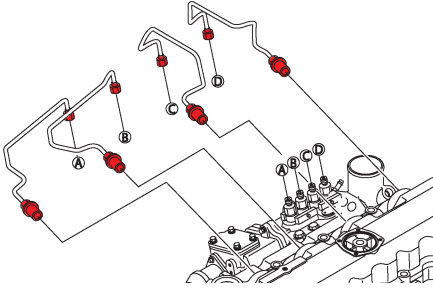
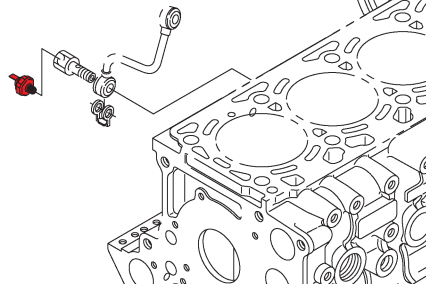
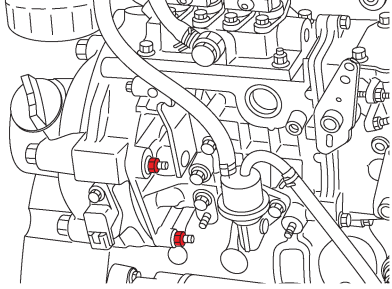
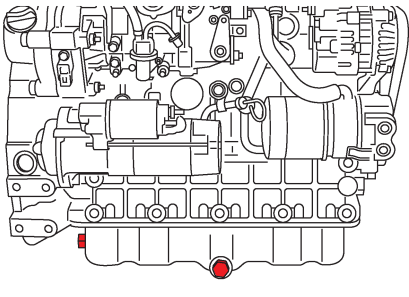
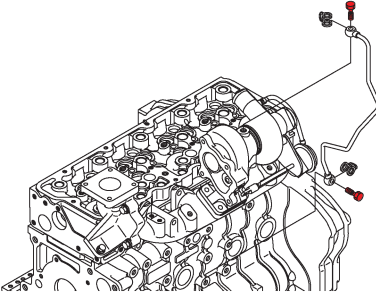
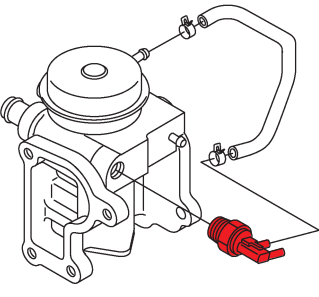
<p>Glow lead mounting nut</p> 	<p>Glow plug</p> 	<p>Cylinder head cover screw</p> 																								
<table border="1"> <tbody> <tr> <td>V2607-DI-E3B</td> <td></td> </tr> <tr> <td>V2607-DI-T-E3B</td> <td>0.98 to 1.7 N·m</td> </tr> <tr> <td>V3007-DI-T-E3B</td> <td>0.10 to 0.18 kgf·m</td> </tr> <tr> <td>V3307-DI-T-E3B</td> <td>0.73 to 1.3 lbf·ft</td> </tr> </tbody> </table>	V2607-DI-E3B		V2607-DI-T-E3B	0.98 to 1.7 N·m	V3007-DI-T-E3B	0.10 to 0.18 kgf·m	V3307-DI-T-E3B	0.73 to 1.3 lbf·ft	<table border="1"> <tbody> <tr> <td>V2607-DI-E3B</td> <td></td> </tr> <tr> <td>V2607-DI-T-E3B</td> <td>7.7 to 9.3 N·m</td> </tr> <tr> <td>V3007-DI-T-E3B</td> <td>0.78 to 0.95 kgf·m</td> </tr> <tr> <td>V3307-DI-T-E3B</td> <td>5.7 to 6.8 lbf·ft</td> </tr> </tbody> </table>	V2607-DI-E3B		V2607-DI-T-E3B	7.7 to 9.3 N·m	V3007-DI-T-E3B	0.78 to 0.95 kgf·m	V3307-DI-T-E3B	5.7 to 6.8 lbf·ft	<table border="1"> <tbody> <tr> <td>V2607-DI-E3B</td> <td></td> </tr> <tr> <td>V2607-DI-T-E3B</td> <td>9.81 to 11.2 N·m</td> </tr> <tr> <td>V3007-DI-T-E3B</td> <td>1.00 to 1.15 kgf·m</td> </tr> <tr> <td>V3307-DI-T-E3B</td> <td>7.24 to 8.31 lbf·ft</td> </tr> </tbody> </table>	V2607-DI-E3B		V2607-DI-T-E3B	9.81 to 11.2 N·m	V3007-DI-T-E3B	1.00 to 1.15 kgf·m	V3307-DI-T-E3B	7.24 to 8.31 lbf·ft
V2607-DI-E3B																										
V2607-DI-T-E3B	0.98 to 1.7 N·m																									
V3007-DI-T-E3B	0.10 to 0.18 kgf·m																									
V3307-DI-T-E3B	0.73 to 1.3 lbf·ft																									
V2607-DI-E3B																										
V2607-DI-T-E3B	7.7 to 9.3 N·m																									
V3007-DI-T-E3B	0.78 to 0.95 kgf·m																									
V3307-DI-T-E3B	5.7 to 6.8 lbf·ft																									
V2607-DI-E3B																										
V2607-DI-T-E3B	9.81 to 11.2 N·m																									
V3007-DI-T-E3B	1.00 to 1.15 kgf·m																									
V3307-DI-T-E3B	7.24 to 8.31 lbf·ft																									
<p>Injection pipe retaining nut</p> 	<p>Oil switch taper screw</p> 	<p>Injection pump unit mounting nut</p> 																								
<table border="1"> <tbody> <tr> <td>V2607-DI-E3B</td> <td></td> </tr> <tr> <td>V2607-DI-T-E3B</td> <td>23 to 36 N·m</td> </tr> <tr> <td>V3007-DI-T-E3B</td> <td>2.3 to 3.7 kgf·m</td> </tr> <tr> <td>V3307-DI-T-E3B</td> <td>17 to 26 lbf·ft</td> </tr> </tbody> </table>	V2607-DI-E3B		V2607-DI-T-E3B	23 to 36 N·m	V3007-DI-T-E3B	2.3 to 3.7 kgf·m	V3307-DI-T-E3B	17 to 26 lbf·ft	<table border="1"> <tbody> <tr> <td>V2607-DI-E3B</td> <td></td> </tr> <tr> <td>V2607-DI-T-E3B</td> <td>15 to 19 N·m</td> </tr> <tr> <td>V3007-DI-T-E3B</td> <td>1.5 to 2.0 kgf·m</td> </tr> <tr> <td>V3307-DI-T-E3B</td> <td>11 to 14 lbf·ft</td> </tr> </tbody> </table>	V2607-DI-E3B		V2607-DI-T-E3B	15 to 19 N·m	V3007-DI-T-E3B	1.5 to 2.0 kgf·m	V3307-DI-T-E3B	11 to 14 lbf·ft	<table border="1"> <tbody> <tr> <td>V2607-DI-E3B</td> <td></td> </tr> <tr> <td>V2607-DI-T-E3B</td> <td>18 to 20 N·m</td> </tr> <tr> <td>V3007-DI-T-E3B</td> <td>1.8 to 2.1 kgf·m</td> </tr> <tr> <td>V3307-DI-T-E3B</td> <td>13 to 15 lbf·ft</td> </tr> </tbody> </table>	V2607-DI-E3B		V2607-DI-T-E3B	18 to 20 N·m	V3007-DI-T-E3B	1.8 to 2.1 kgf·m	V3307-DI-T-E3B	13 to 15 lbf·ft
V2607-DI-E3B																										
V2607-DI-T-E3B	23 to 36 N·m																									
V3007-DI-T-E3B	2.3 to 3.7 kgf·m																									
V3307-DI-T-E3B	17 to 26 lbf·ft																									
V2607-DI-E3B																										
V2607-DI-T-E3B	15 to 19 N·m																									
V3007-DI-T-E3B	1.5 to 2.0 kgf·m																									
V3307-DI-T-E3B	11 to 14 lbf·ft																									
V2607-DI-E3B																										
V2607-DI-T-E3B	18 to 20 N·m																									
V3007-DI-T-E3B	1.8 to 2.1 kgf·m																									
V3307-DI-T-E3B	13 to 15 lbf·ft																									
<p>Drain plug</p> 	<p>Oil pipe1 mounting screw</p> 	<p>Thermo valve</p> 																								
<table border="1"> <tbody> <tr> <td>V2607-DI-E3B</td> <td></td> </tr> <tr> <td>V2607-DI-T-E3B</td> <td>45 to 53 N·m</td> </tr> <tr> <td>V3007-DI-T-E3B</td> <td>4.5 to 5.5 kgf·m</td> </tr> <tr> <td>V3307-DI-T-E3B</td> <td>33 to 39 lbf·ft</td> </tr> </tbody> </table>	V2607-DI-E3B		V2607-DI-T-E3B	45 to 53 N·m	V3007-DI-T-E3B	4.5 to 5.5 kgf·m	V3307-DI-T-E3B	33 to 39 lbf·ft	<table border="1"> <tbody> <tr> <td>V2607-DI-T-E3B</td> <td></td> </tr> <tr> <td>V3007-DI-T-E3B</td> <td>16 to 19 N·m</td> </tr> <tr> <td>V3307-DI-T-E3B</td> <td>1.6 to 2.0 kgf·m</td> </tr> <tr> <td>V3307-DI-T-E3B</td> <td>12 to 14 lbf·ft</td> </tr> </tbody> </table>	V2607-DI-T-E3B		V3007-DI-T-E3B	16 to 19 N·m	V3307-DI-T-E3B	1.6 to 2.0 kgf·m	V3307-DI-T-E3B	12 to 14 lbf·ft	<table border="1"> <tbody> <tr> <td>V2607-DI-T-E3B</td> <td></td> </tr> <tr> <td>V3007-DI-T-E3B</td> <td>30 to 39 N·m</td> </tr> <tr> <td>V3307-DI-T-E3B</td> <td>3.0 to 4.0 kgf·m</td> </tr> <tr> <td>V3307-DI-T-E3B</td> <td>22 to 28 lbf·ft</td> </tr> </tbody> </table>	V2607-DI-T-E3B		V3007-DI-T-E3B	30 to 39 N·m	V3307-DI-T-E3B	3.0 to 4.0 kgf·m	V3307-DI-T-E3B	22 to 28 lbf·ft
V2607-DI-E3B																										
V2607-DI-T-E3B	45 to 53 N·m																									
V3007-DI-T-E3B	4.5 to 5.5 kgf·m																									
V3307-DI-T-E3B	33 to 39 lbf·ft																									
V2607-DI-T-E3B																										
V3007-DI-T-E3B	16 to 19 N·m																									
V3307-DI-T-E3B	1.6 to 2.0 kgf·m																									
V3307-DI-T-E3B	12 to 14 lbf·ft																									
V2607-DI-T-E3B																										
V3007-DI-T-E3B	30 to 39 N·m																									
V3307-DI-T-E3B	3.0 to 4.0 kgf·m																									
V3307-DI-T-E3B	22 to 28 lbf·ft																									

Nozzle holder clamp screw

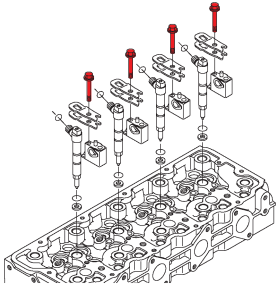

V2607-DI-E3B	
V2607-DI-T-E3B	24 to 27 N·m
V3007-DI-T-E3B	2.4 to 2.8 kgf·m
V3307-DI-T-E3B	18 to 20 lbf·ft

Overflow pipe assembly retaining screw

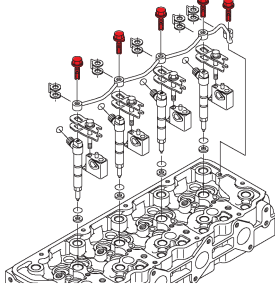

V2607-DI-E3B	
V2607-DI-T-E3B	9.81 to 11.2 N·m
V3007-DI-T-E3B	1.00 to 1.15 kgf·m
V3307-DI-T-E3B	7.24 to 8.31 lbf·ft

Rocker arm bracket screw

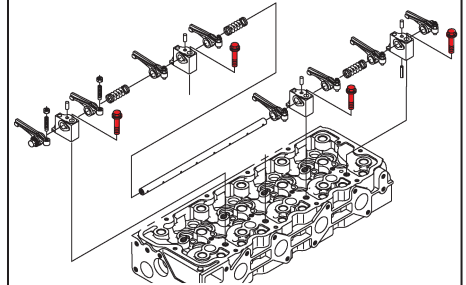

V2607-DI-E3B	
V2607-DI-T-E3B	24 to 27 N·m
V3007-DI-T-E3B	2.4 to 2.8 kgf·m
V3307-DI-T-E3B	18 to 20 lbf·ft

Rocker arm bracket screw

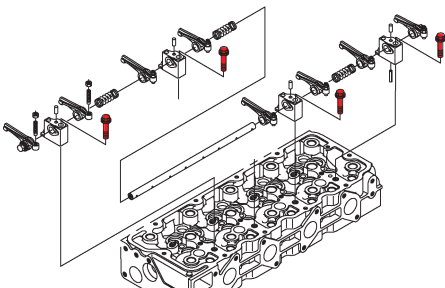

V3007-DI-T-E3B	49 to 55 N·m
V3307-DI-T-E3B	5.0 to 5.7 kgf·m
	37 to 41 lbf·ft

Cylinder head mounting screw *

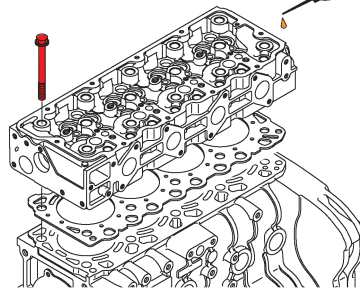

V2607-DI-E3B	147 to 156 N·m
V2607-DI-T-E3B	15.0 to 16.0 kgf·m
	109 to 115 lbf·ft

Cylinder head mounting screw *

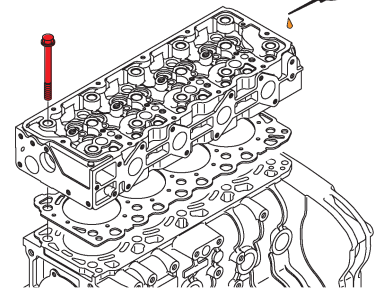

V3007-DI-T-E3B	187 to 196 N·m
V3307-DI-T-E3B	19.0 to 20.0 kgf·m
	138 to 144 lbf·ft

Cylinder head mounting screw tightening order

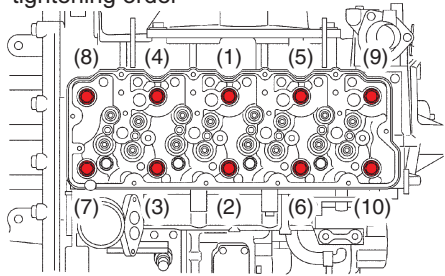

V2607-DI-E3B	
V2607-DI-T-E3B	
V3007-DI-T-E3B	(1) → (10)
V3307-DI-T-E3B	

Lubricating oil pipe mounting screw

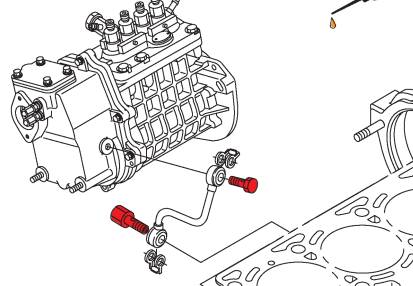

V2607-DI-E3B	
V2607-DI-T-E3B	16 to 19 N·m
V3007-DI-T-E3B	1.6 to 2.0 kgf·m
V3307-DI-T-E3B	12 to 14 lbf·ft

Governor housing mounting screw

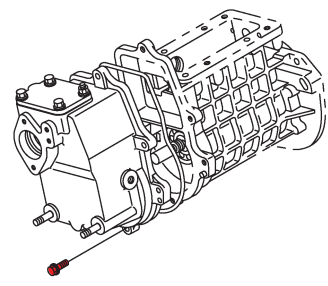

V2607-DI-E3B	
V2607-DI-T-E3B	9.81 to 11.2 N·m
V3007-DI-T-E3B	1.00 to 1.15 kgf·m
V3307-DI-T-E3B	7.24 to 8.31 lbf·ft

Lock nut

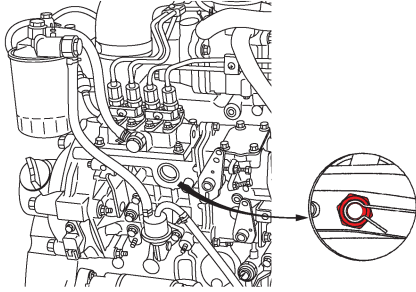

V2607-DI-E3B

2.9 to 4.0 N·m

V2607-DI-T-E3B

0.29 to 0.41 kgf·m

V3007-DI-T-E3B

2.1 to 2.9 lbf·ft

V3307-DI-T-E3B

Injection pump assembly mounting screw

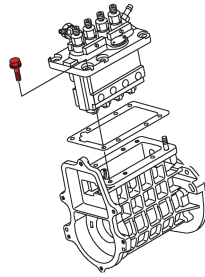

V2607-DI-E3B

24 to 27 N·m

V2607-DI-T-E3B

2.4 to 2.8 kgf·m

V3007-DI-T-E3B

18 to 20 lbf·ft

V3307-DI-T-E3B

Injection pump assembly mounting nut

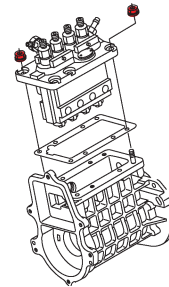

V2607-DI-E3B

18 to 20 N·m

V2607-DI-T-E3B

1.8 to 2.1 kgf·m

V3007-DI-T-E3B

13 to 15 lbf·ft

V3307-DI-T-E3B

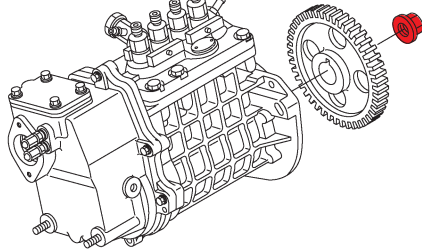
Injection pump gear mounting nut
(Left-handed screw)

V2607-DI-E3B

93.2 to 102 N·m

9.50 to 10.5 kgf·m

V2607-DI-T-E3B

68.8 to 75.9 lbf·ft

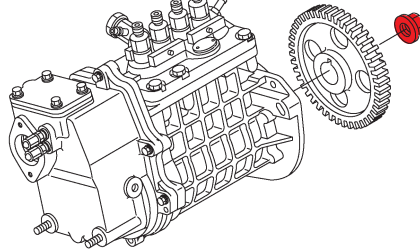
Injection pump gear mounting nut
(Left-handed screw)

V3007-DI-T-E3B

138 to 158 N·m

14.0 to 16.0 kgf·m

V3307-DI-T-E3B

102 to 115 lbf·ft

Governor weight mounting nut

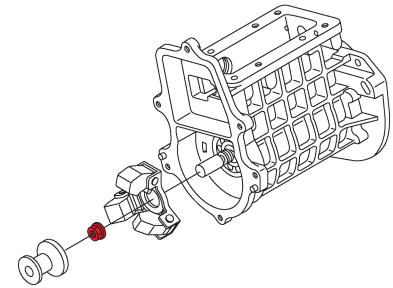

V2607-DI-E3B

63 to 72 N·m

V2607-DI-T-E3B

6.4 to 7.4 kgf·m

V3007-DI-T-E3B

47 to 53 lbf·ft

V3307-DI-T-E3B

Fuel camshaft stopper mounting screw

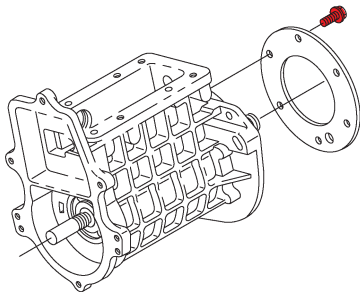

V2607-DI-E3B

9.81 to 11.2 N·m

V2607-DI-T-E3B

1.00 to 1.15 kgf·m

V3007-DI-T-E3B

7.24 to 8.31 lbf·ft

V3307-DI-T-E3B

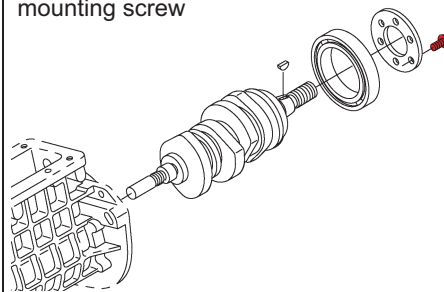
Fuel camshaft bearing stopper
mounting screw

V2607-DI-E3B

3.9 to 4.2 N·m

V2607-DI-T-E3B

0.39 to 0.43 kgf·m

V3007-DI-T-E3B

2.9 to 3.1 lbf·ft

V3307-DI-T-E3B

Crankshaft screw *

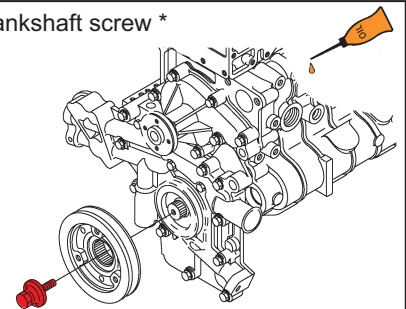

V2607-DI-E3B

255 to 274 N·m

V2607-DI-T-E3B

26.0 to 28.0 kgf·m

V3007-DI-T-E3B

188 to 202 lbf·ft

V3307-DI-T-E3B

Oil cooler joint screw

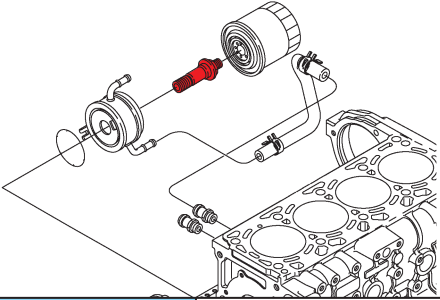

V2607-DI-E3B

64 to 73 N·m
6.5 to 7.5 kgf·m
47 to 54 lbf·ft

V2607-DI-T-E3B

Oil cooler joint screw

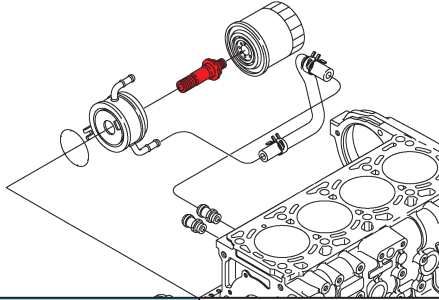

V3007-DI-T-E3B

40 to 44 N·m
4.0 to 4.5 kgf·m
29 to 32 lbf·ft

V3307-DI-T-E3B

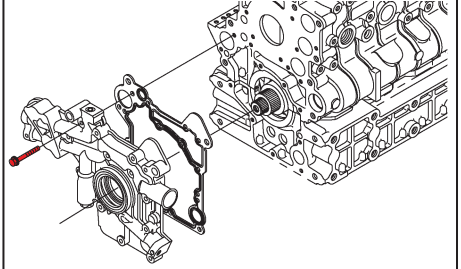
Front cover mounting screw
[7T screw]

V2607-DI-E3B

24 to 27 N·m
2.4 to 2.8 kgf·m
18 to 20 lbf·ft

V2607-DI-T-E3B

V3007-DI-T-E3B

V3307-DI-T-E3B

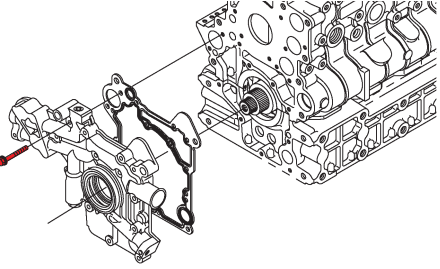
Front cover mounting screw
[10T screw]

V3007-DI-T-E3B

30 to 34 N·m
3.0 to 3.5 kgf·m
22 to 25 lbf·ft

V3307-DI-T-E3B

Relief valve retaining screw

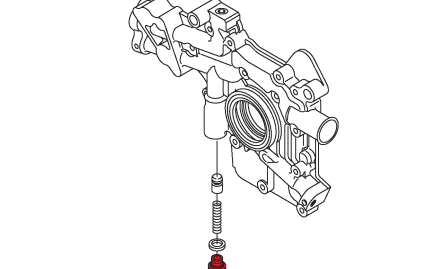

V2607-DI-E3B

69 to 78 N·m
7.0 to 8.0 kgf·m
51 to 57 lbf·ft

V2607-DI-T-E3B

V3007-DI-T-E3B

V3307-DI-T-E3B

Flywheel screw *

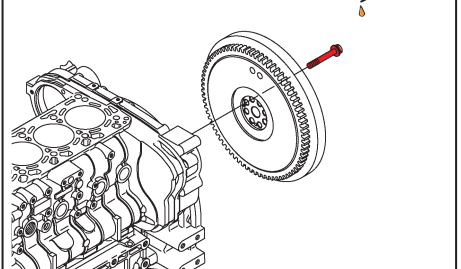

V2607-DI-E3B

98.1 to 107 N·m
10.0 to 11.0 kgf·m
72.4 to 79.5 lbf·ft

V2607-DI-T-E3B

V3007-DI-T-E3B

V3307-DI-T-E3B

Flywheel housing mounting screw

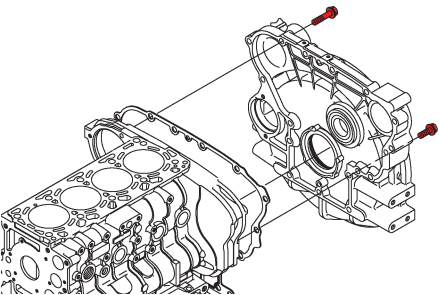

V2607-DI-E3B

78 to 90 N·m
7.9 to 9.2 kgf·m
58 to 66 lbf·ft

V2607-DI-T-E3B

Flywheel housing mounting screw (9T)

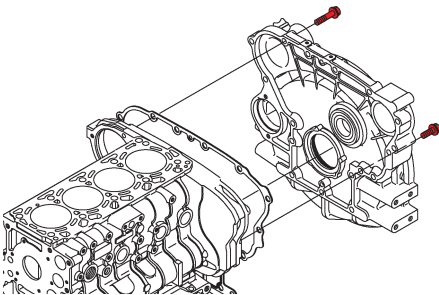

V3007-DI-T-E3B

103 to 117 N·m
10.5 to 12.0 kgf·m
76.0 to 86.7 lbf·ft

V3307-DI-T-E3B

Camshaft set screw

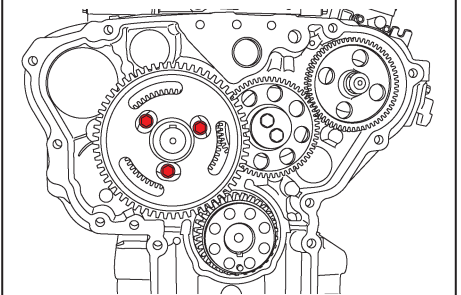

V2607-DI-E3B

24 to 27 N·m
2.4 to 2.8 kgf·m
18 to 20 lbf·ft

V2607-DI-T-E3B

V3007-DI-T-E3B

V3307-DI-T-E3B

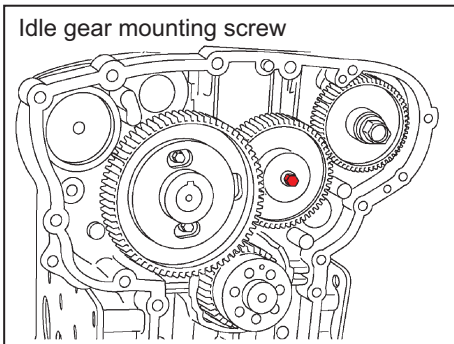

Idle gear mounting screw

V2607-DI-E3B	49 to 55 N·m 5.0 to 5.7 kgf·m
V2607-DI-T-E3B	37 to 41 lbf·ft

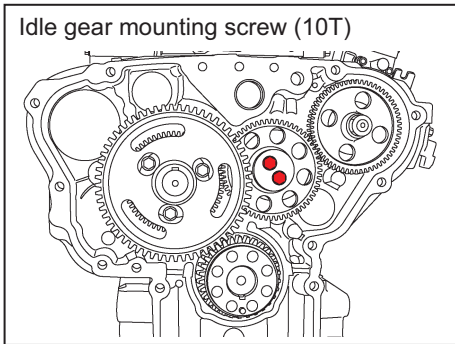

Idle gear mounting screw (10T)

V3007-DI-T-E3B	30 to 34 N·m 3.0 to 3.5 kgf·m
V3307-DI-T-E3B	22 to 25 lbf·ft

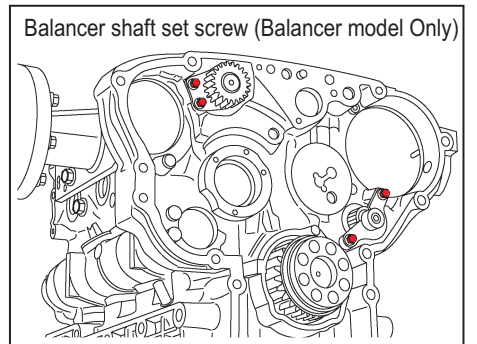

Balancer shaft set screw (Balancer model Only)

V3007-DI-T-E3B	24 to 27 N·m 2.4 to 2.8 kgf·m
V3307-DI-T-E3B	18 to 20 lbf·ft

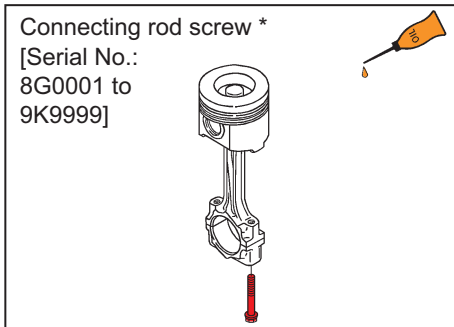

Connecting rod screw *
[Serial No.:
8G0001 to
9K9999]

V2607-DI-T-E3B	45 to 49 N·m 4.5 to 5.0 kgf·m 33 to 36 lbf·ft
----------------	---

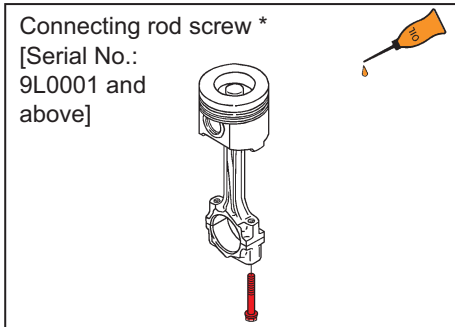

Connecting rod screw *
[Serial No.:
9L0001 and
above]

V2607-DI-E3B	41 to 45 N·m 4.1 to 4.6 kgf·m
V2607-DI-T-E3B	30 to 33 lbf·ft

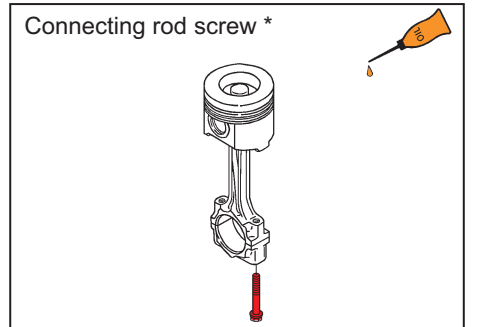

Connecting rod screw *

V3007-DI-T-E3B	69 to 73 N·m 7.0 to 7.5 kgf·m
V3307-DI-T-E3B	51 to 54 lbf·ft

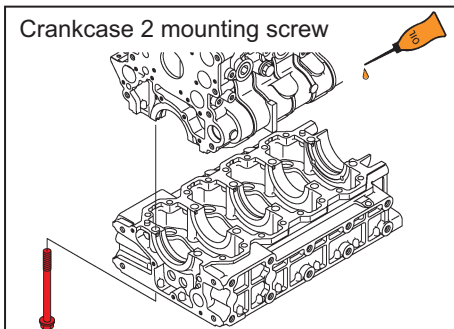

Crankcase 2 mounting screw

V2607-DI-E3B	128 to 137 N·m 13.0 to 14.0 kgf·m
V2607-DI-T-E3B	94.1 to 101 lbf·ft

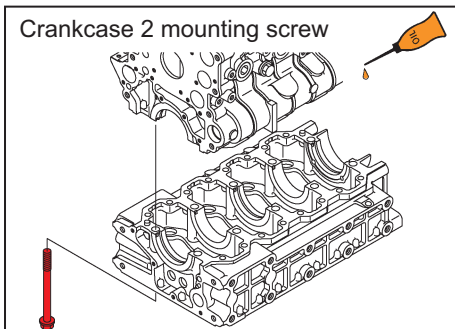

Crankcase 2 mounting screw

V3007-DI-T-E3B	138 to 147 N·m 14.0 to 15.0 kgf·m
V3307-DI-T-E3B	102 to 108 lbf·ft

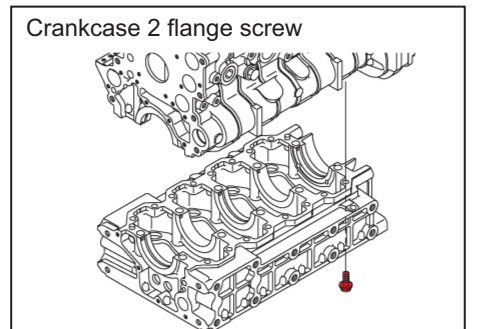

Crankcase 2 flange screw

V2607-DI-E3B	49 to 55 N·m 5.0 to 5.7 kgf·m
V2607-DI-T-E3B	37 to 41 lbf·ft

Crankcase 2 flange screw (9T)

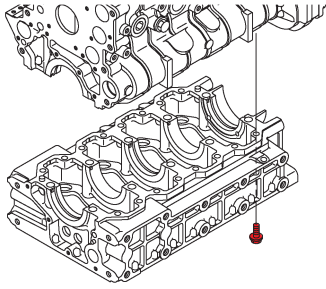

V3007-DI-T-E3B	59 to 63 N·m 6.0 to 6.5 kgf·m
V3307-DI-T-E3B	44 to 47 lbf·ft

Starter's terminal B mounting nut

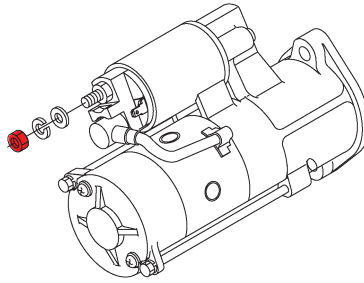

V2607-DI-E3B	9.8 to 11 N·m
V2607-DI-T-E3B	1.0 to 1.2 kgf·m
V3007-DI-T-E3B	7.3 to 8.6 lbf·ft
V3307-DI-T-E3B	

Alternator pulley nut

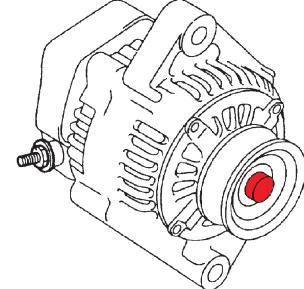

V2607-DI-E3B	58.4 to 78.9 N·m
V2607-DI-T-E3B	5.95 to 8.05 kgf·m
V3007-DI-T-E3B	43.1 to 58.2 lbf·ft
V3307-DI-T-E3B	

Oil pump cover screw

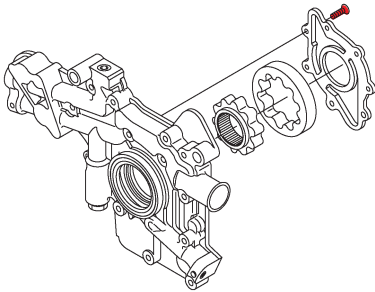

V2607-DI-E3B	7.9 to 9.3 N·m
V2607-DI-T-E3B	0.80 to 0.95 kgf·m
V3007-DI-T-E3B	5.8 to 6.8 lbf·ft
V3307-DI-T-E3B	

(2) General Tightening Torques

Screw and bolt material grades are shown by numbers punched on the screw and bolt heads.

Prior to tightening, be sure to check out the numbers as shown below.

None or 4 : Standard grade

7 : Special grade

Nominal Diameter	Standard Grade	Special Grade
M6	7.9 to 9.3 N·m 0.80 to 0.95 kgf·m 5.8 to 6.8 lbf·ft	9.81 to 11.2 N·m 1.00 to 1.15 kgf·m 7.24 to 8.31 lbf·ft
M8	18 to 20 N·m 1.8 to 2.1 kgf·m 13 to 15 lbf·ft	24 to 27 N·m 2.4 to 2.8 kgf·m 18 to 20 lbf·ft
M10	40 to 45 N·m 4.0 to 4.6 kgf·m 29 to 33 lbf·ft	48 to 55 N·m 4.9 to 5.7 kgf·m 36 to 41 lbf·ft
M12	63 to 72 N·m 6.4 to 7.4 kgf·m 47 to 53 lbf·ft	78 to 90 N·m 7.9 to 9.2 kgf·m 58 to 66 lbf·ft