

# Fettschmierverschlauchungsplan Lubrication hose diagram

**Super 1600-3 / 1600-3i**

**1582**  
Baureihe /  
Series

**0010 - XXXX**  
Seriennummer /  
Serial No

**21.02.2017**  
Ausgabedatum /  
Date of issue

**FVP\_1582\_2342387\_01\_00\_01**  
Katalog Bestellnummer /  
Catalogue order No

**Schutzvermerk nach ISO 16016**

Weitergabe sowie Vervielfältigung dieses Dokuments, Verwertung und Mitteilung seines Inhalts sind verboten, soweit nicht ausdrücklich gestattet.

Zuwiderhandlungen verpflichten zum Schadenersatz. Alle Rechte für den Fall der Patent-, Gebrauchsmuster- oder Geschmacksmustereintragung vorbehalten.

**Protection Notice ISO 16016**

The reproduction, distribution and utilization of this document as well as the communication of its contents to others without explicit authorization is prohibited.

Offenders will be held liable for the payment of damages. All rights reserved in the event of the grant of a patent, utility model or design.

Hydraulics  
Schutzvermerk nach ISO 16016 beachten  
Refer to protection notice ISO 16016  
© 2014 by Joseph Vögele AG

1 2 3 4 5 6 7 8

Blatt / Sheet	Inhalt / Contents	Blatt / Sheet	Inhalt / Contents
1	Deckblatt cover sheet		
2	Inhaltsverzeichnis contents		
3	Topologie topology		
4	Fettschmieranlage Pumpe grease lubrication pump		
5	Fettschmieranlage Verteilerschnecke grease lubrication auger		
6	Fettschmieranlage Kratzerband grease lubrication conveyor		
7	Erklärung Gerätekenbuchstaben, hydraulisch Explanation device code letter, hydraulic		
8	Symbole Hydraulikverschraubungen symbols hydraulic connections		

Drawing by:		Approved by:		last change:		Status:		Material No.:		Document No.: Partial Document No.: Version No.:		Sheet	
date	12.03.2014	date	21.02.2017	date		<b>SF</b>	AE =changable	2342387				2	
name	Keilmann	name	Holzmann	name			PF =prototype release	Revision No.:				of	
E - CAE		Document type:		Function group No.:			SF =serial release	01				8	
		<b>FVP</b>						 <b>VÖGELE</b>		Series code:		Valid for Serial No.:	
										1582		from 0010 to XXXX	
										Sheet plant:			
										Sheet Location:			

1 2 3 4 5 6 7 8

Hydraulics  
Schutzvermerk nach ISO 16016 beachten  
Refer to protection notice ISO 16016

1 2 3 4 5 6 7 8

-HG1

-HX1

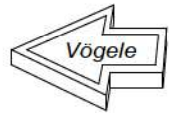

<b>Drawing by:</b>		<b>Approved by:</b>		<b>last change:</b>		<b>Status:</b>		<b>Material No.:</b>		<b>Document No.:</b> Partial Document No.: Version No.:		<b>Topology</b>		<b>Sheet</b>			
date	12.03.2014	date	21.02.2017	date		<b>SF</b>	AE =changable	2342387				<b>Topologie</b> <b>topology</b>		<b>3</b> of			
name	Keilmann	name	Holzmann	name			PF =prototype release	Revision No.:		Series code:						Valid for Serial No.:	
E - CAE		<b>Document type:</b>		<b>Function group No.:</b>			SF =serial release		01		1582					from 0010 to XXXX	
<b>FVP</b>										<b>Sheet plant:</b>							
<b>Sheet Location:</b>																	

1 2 3 4 5 6 7 8

© 2014 by Joseph Vögele AG

Schutzvermerk nach ISO 16016 beachten

1 2 3 4 5 6 7 8

Hydraulics

- HX1**  
2013481
- 2 x M6x50 9506340933
  - 4 x Ø 6,4 9500060125
  - 2 x M6 9500060934

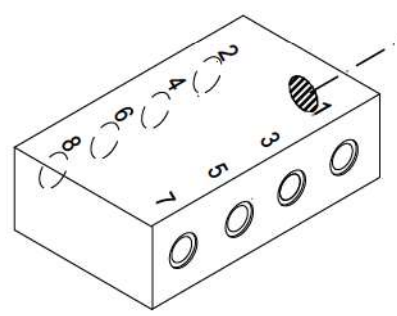

- HG1**  
2013478
- 3 x M8x16 9508160933
  - 3 x Ø 8,4 9500080125
  - 2kg Sonderfett 3506021013

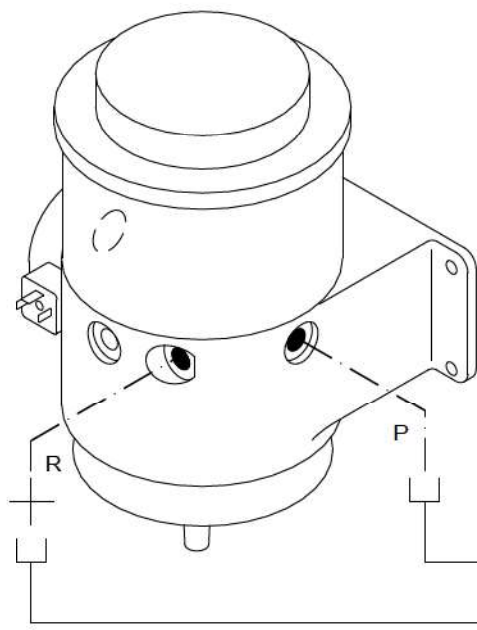

GEV G1/4-06L  
9602060057

2324346   
DN 06

2324340   
DN 06

/5.3 **R-HG1**

- 01  
Revision
- 1x Ø 22 2522250
  - 1x M8x20 9508200933

- 1x Halter 2327760
- 3 x M8x16 9508160933
- 3 x Ø 8,4 9500080125
- 1x 2005611
- 0,05m DICHTUNGSPROFIL 4604042241

- 01  
Revision
- 1x Ø 40 2004493



2281715 5 x 378x7 3515080179

Drawing by:		Approved by:		last change:		Status:		Material No.:		Document No.: Partial Document No.: Version No.:		Sheet	
date	12.03.2014	date	21.02.2017	date	17.02.2017	<b>SF</b>	AE =changable	2342387		Series code: 1582		Valid for Serial No.:	
name	Keilmann	name	Holzmann	name	Greulich		PF =prototype release	Revision No.: 01		Valid for Serial No.:		from 0010 to XXXX	
E - CAE		Document type: <b>FVP</b>		Function group No.:			SF =serial release				Sheet plant:		4
								<b>VÖGELE</b>		Sheet Location:		8	

© 2014 by Joseph Vögele AG



Hydraulics  
Schutzvermerk nach ISO 16016 beachten  
Refer to protection notice ISO 16016

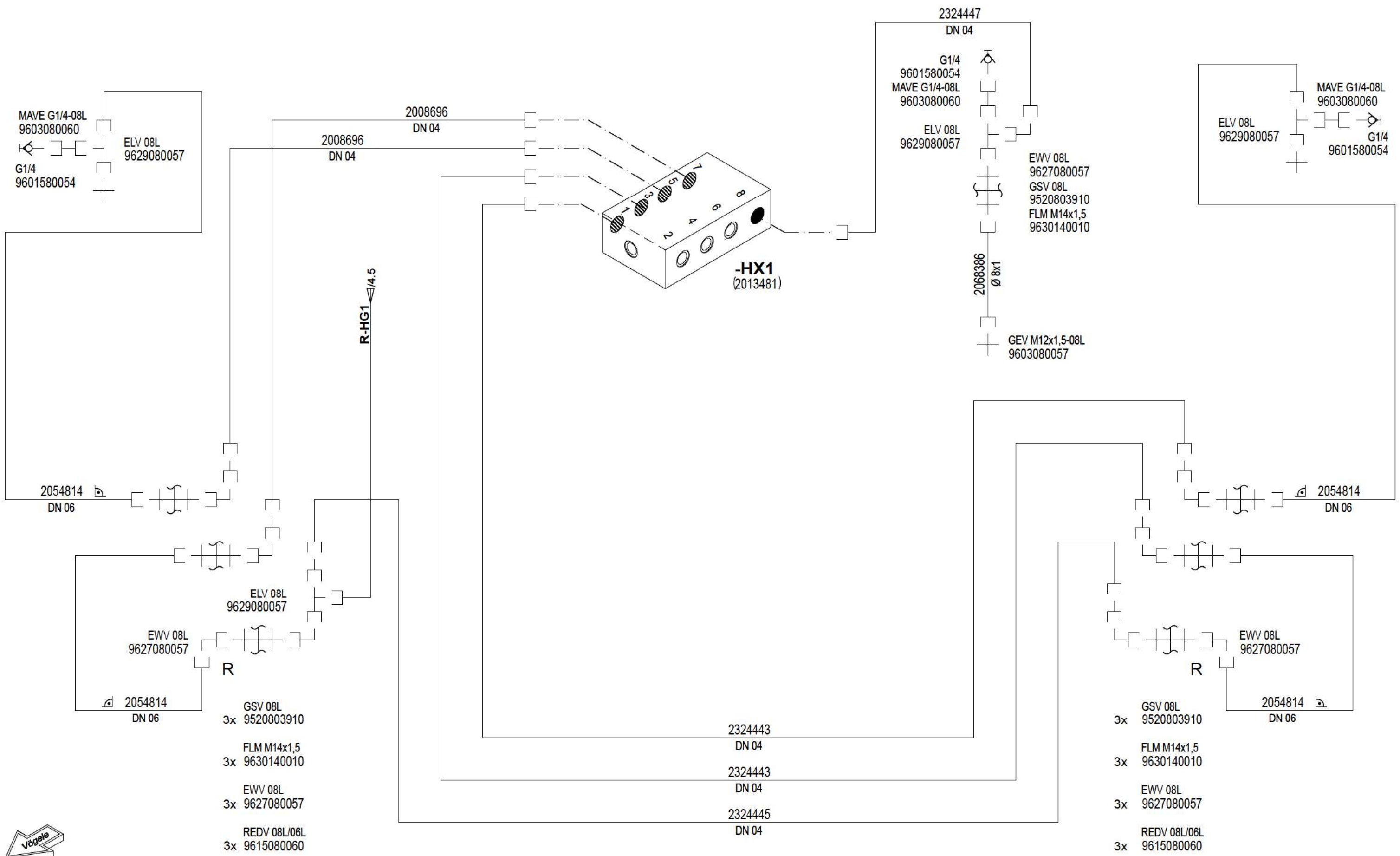

2284404

Drawing by:		Approved by:		last change:		Status:		Material No.:		Document No.: Partial Document No.: Version No.:		Fettschmieranlage Verteilerschnecke grease lubrication auger		Sheet 5 of 8 Sheets	
date	12.03.2014	date	21.02.2017	date		SF AE =changable PF =prototype release SF =serial release		2342387							
name	Keilmann	name	Holzmann	name				Revision No.:		Series code:		Valid for Serial No.:			
E - CAE		Document type:		Function group No.:				01		1582		from 0010 to XXXX			
		FVP								Sheet plant:					
										Sheet Location:					

© 2014 by Joseph Vögele AG

Schutzvermerk nach ISO 16016 beachten

Refer to protection notice ISO 16016

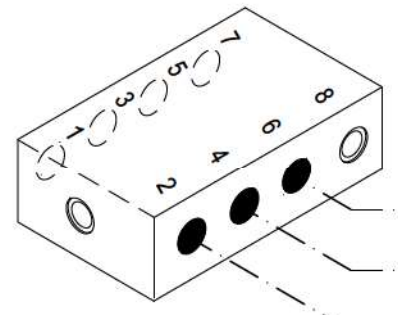

**-HX1**  
(2013481)

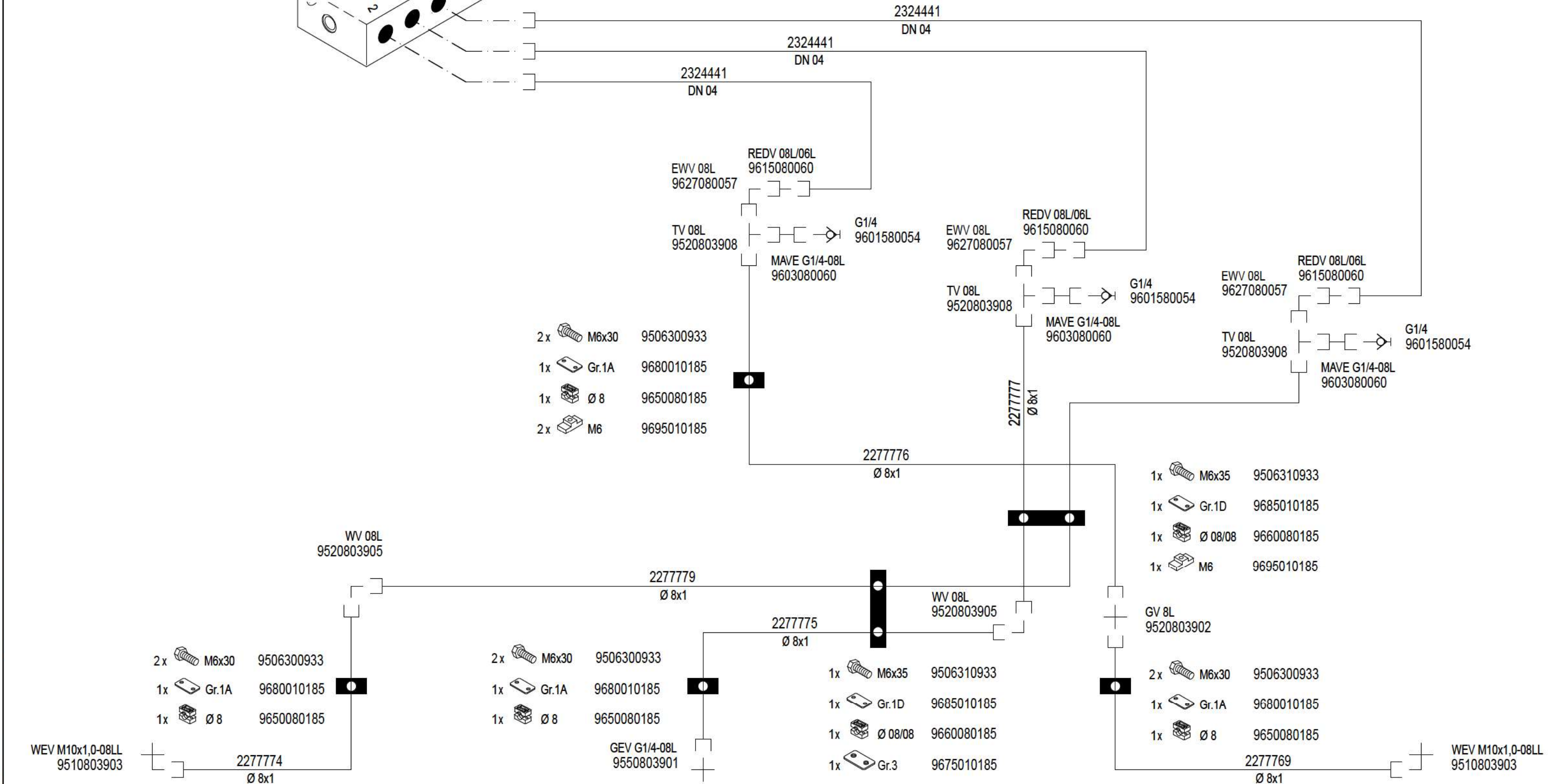

- 2x M6x30 9506300933
- 1x Gr.1A 9680010185
- 1x Ø 8 9650080185
- 2x M6 9695010185

- 1x M6x35 9506310933
- 1x Gr.1D 9685010185
- 1x Ø 08/08 9660080185
- 1x M6 9695010185

- 2x M6x30 9506300933
- 1x Gr.1A 9680010185
- 1x Ø 8 9650080185

- 2x M6x30 9506300933
- 1x Gr.1A 9680010185
- 1x Ø 8 9650080185

- 1x M6x35 9506310933
- 1x Gr.1D 9685010185
- 1x Ø 08/08 9660080185
- 1x Gr.3 9675010185

- GV 8L 9520803902
- 2x M6x30 9506300933
- 1x Gr.1A 9680010185
- 1x Ø 8 9650080185



2279053

Drawing by:		Approved by:		last change:		Status:		Material No.:		Document No.: Partial Document No.: Version No.:		Sheet:	
date	12.03.2014	date	21.02.2017	date		SF AE =changable PF =prototype release SF =serial release		2342387				6	
name	Keilmann	name	Holzmann	name				Revision No.:		Series code:		Valid for Serial No.:	
E - CAE		Document type:		Function group No.:				01		1582		from 0010 to XXXX	
FVP										Sheet plant:		Fettschmieranlage Kratzerband grease lubrication conveyor	
										Sheet Location:		8	

© 2014 by Joseph Vögele AG



## Gerätekenbuchstaben, hydraulisch (beispielhaft) / device code letter, hydraulic (exemplified)













































<u>Gerätekenbuchstabe / device code letter</u>	<u>Deutsch</u>	<u>English</u>	<u>Gerätekenbuchstabe / device code letter</u>	<u>Deutsch</u>	<u>English</u>
- HA	Ventilblock	valve-block	- HP	Manometer	pressure gauge
- HB	Durchflussmesser Durchflusswächter Druckschalter hydraulisch	flow measuring device flow controller hydraulic pressure switch	- HQ	Bremsventil Kugelhahn Lenkeinheit Wegeventil	braking valve ball valve steering unit direction control valve
- HC	Speicher	accumulator	- HR	Drosselventil Drosselrückschlagventil Druckreduzierventil Lasthalteventil Rückschlagventil	throttle valve throttle check valve pressure reduction valve counter balance valve check valve
- HE	Kühler	cooler	- HT	Getriebe	gearbox
- HF	Druckbegrenzungsventil	pressure limiting valve	- HV	Hydraulikfilter	hydraulic filter
- HG	Hydraulikpumpe	hydraulic pump	- HX	Abdeckplatten Reihenflanschplatte Schnellkupplung	cover plates manifold plate quick-action coupling
- HK	Mengenteiler Prioritätsventil Stromregelventil	flow divider priority valve flow control valve	- Ma	Ventil Magnetspule a	valve coil a
- HM	Hydraulikmotor Hydraulikzylinder	hydraulic motor hydraulic cylinder	- Mb	Ventil Magnetspule b	valve coil b

Drawing by:	Approved by:	last change:	Status:	Material No.:	Document No.:	Partial Document No.:	Version No.:	Erklärung Gerätekenbuchstaben, hydraulisch Explanation device code letter, hydraulic	Sheet
date 12.03.2014	date 21.02.2017	date	SF	2342387					7
name Keilmann	name Holzmann	name		AE =changable	Revision No.:				
E - CAE	Document type: <b>FVP</b>	Function group No.:	PF =prototype release SF =serial release	01	Series code: 1582	Valid for Serial No.:	from 0010 to XXXX		8
				<b>VÖGELE</b>	Sheet plant: Sheet Location:			8	

Hydraulics  
Schutzvermerk nach ISO 16016 beachten  
Refer to protection notice ISO 16016  
© 2014 by Joseph Vögele AG

# Symbole, Hydraulikverschraubungen

## symbols, hydraulic connections

 <b>ASV</b>	Anschweißverschraubung weld connector	 <b>GSV</b>	Gerade Schottverschraubung bulkhead union	 <b>ROV</b>	Rohr-Verschlussverschraubung blanking plug for tube ends	 <b>EWW</b>	Doppelverbinder swivel elbow
 <b>DA</b>	Distanzadapter distance piece adapter	 <b>GV</b>	Gerade Verschraubung union	 <b>SR</b>	Schneidring cutting ring	 <b>EVV</b>	Einstellbare Winkelverschraubung swivel elbow
 <b>DV</b>	Drosselverschraubung throttle union	 <b>GZV</b>	Gerade Zwischenverschraubung swivel union	 <b>SWV</b>	Schwenkverschraubung banjo elbow		
 <b>EGE</b>	Gerader Einschraubstutzen (Dichtkegel) swivel connector	 <b>HS</b>	Hohlschraube hollow screw	 <b>TV</b>	T-Verschraubung union tee		
 <b>ELV</b>	Einstellbare L-Verschraubung swivel nut run tee	 <b>KOR</b>	Konus-Reduzieranschluss tube end reducer	 <b>UEM</b>	Überwurfmutter nut		
 <b>ESV</b>	Einschweis-Schottverschraubung weld bulkhead fitting	 <b>KV</b>	Kreuzverschraubung union cross	 <b>VKA</b>	Verschlussstopfen inkl. Überwurfmutter blanking plug with nut for cones		
 <b>ETV</b>	Einstellbare T-Verschraubung swivel nut branch tee	 <b>MAV</b>	Manometer-Aufschraubstutzen pressure gauge connector	 <b>VS</b>	Verschlussstopfen blanking plug for cones		
 <b>EWW</b>	Einstellbare Winkelverschraubung swivel elbow	 <b>MAVE</b>	Manometer-Verschraubung pressure gauge swivel connector	 <b>VSS</b>	Verschlusssschraube blanking plug for ports		
 <b>FLM</b>	Flachmutter locknut for bulkheads	 <b>Minim. DKO</b>	Aufschraub-Messanschluss female measuring connector	 <b>VSTI</b>	Verschlusssschraube blanking plug for ports		
 <b>GAI</b>	Gerader Aufschraubstutzen female connector	 <b>Minim. GEV</b>	Einschraub-Messanschluss male stud measuring connector	 <b>WEE</b>	Einstellbare Winkeleinschraubverschraubung - adjustable elbow		
 <b>GEV</b>	Gerade Einschraubverschraubung male stud connector	 <b>Minim. GV</b>	Gerader Messanschluss measuring union	 <b>WFL</b>	Winkel-Flanschverschraubung L-Serie elbow flange adapter L-series		
 <b>GFL</b>	Gerade Flanschverschraubung L-Reihe straight flange adapter L-series	 <b>REDV</b>	Reduzierschraubung tube end reducer	 <b>WFS</b>	Winkel-Flanschverschraubung S-Serie elbow flange adapter S-series		
 <b>GFS</b>	Gerade Flanschverschraubung S-Reihe straight flange adapter S-series	 <b>RI</b>	Gewinde Reduzierstutzen thread reducer	 <b>WSV</b>	Winkel-Schottverschraubung bulkhead elbow		
 <b>GRV</b>	Gerade Reduzierschraubung straight reducer	 <b>RIG</b>	Ringauge banjo	 <b>WV</b>	Winkelverschraubung union elbow		

Drawing by:		Approved by:		last change:		Status:		Material No.:		Document No.: Partial Document No.: Version No.:		Sheet <b>8</b> of <b>8</b> Sheets			
date	12.03.2014	date	21.02.2017	date		<b>SF</b> AE =changable PF =prototype release SF =serial release	2342387				Series code: <b>1582</b>		Valid for Serial No.: from <b>0010</b> to <b>XXXX</b>		
name	Keilmann	name	Holzmann	name			Revision No.:							Sheet plant:	
E - CAE		Document type:		Function group No.:			01							Sheet Location:	
		<b>FVP</b>													

Symbole Hydraulikverschraubungen  
symbols hydraulic connections