

Schutzvermerk nach ISO 16016 beachten/Refer to protection notice ISO 16016

1 2 3 4 5 6 7 8

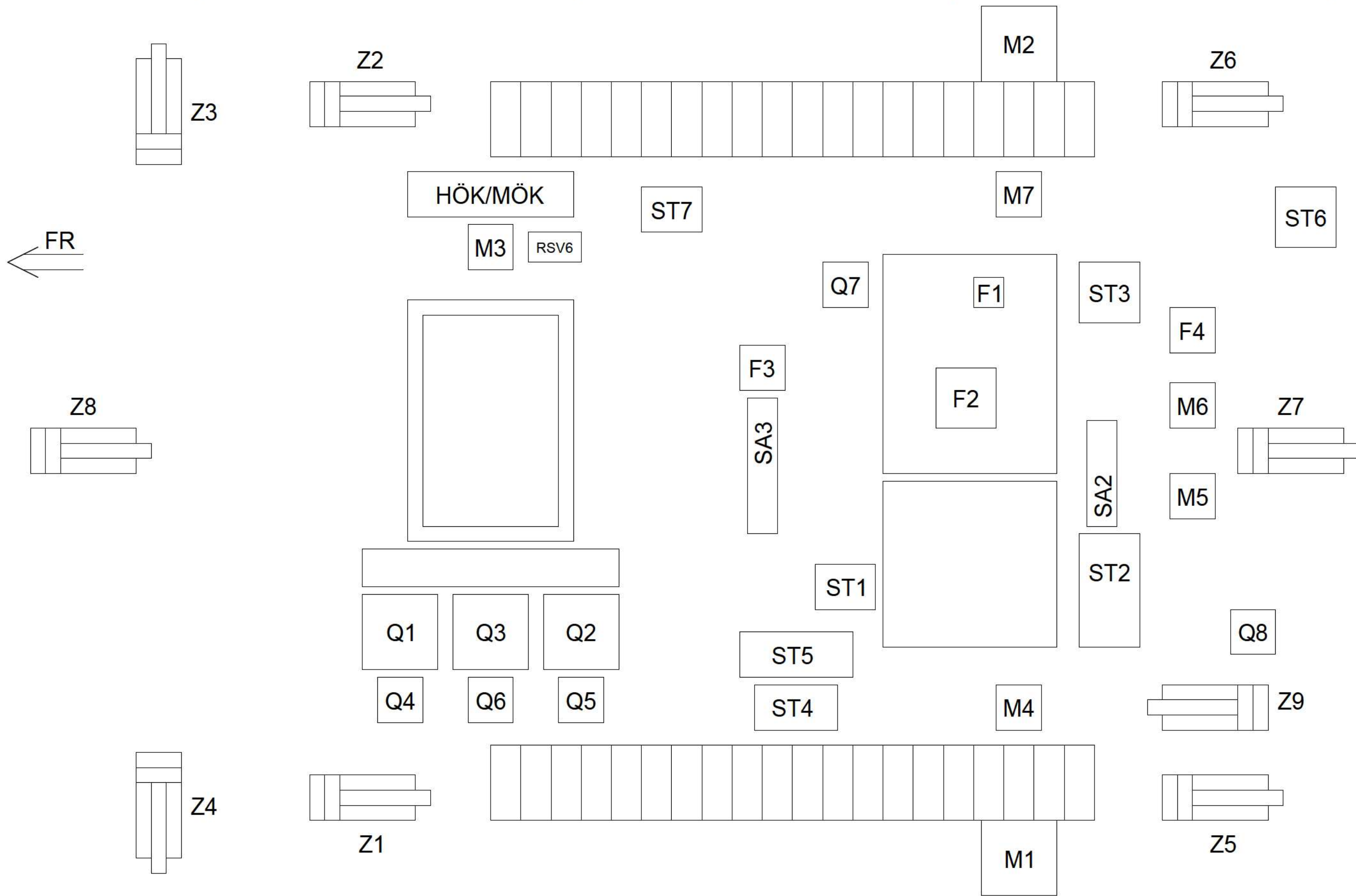

Modification	Date	Name	Date	Name	Machine Key Code:	Ident-No.:	Spot:	Plan
a					08.11	2173308 00		
b			07.10.09	Letz				
c					0811 0409 - XXXX	Pumpenanordnung		Bl.: 2
d						pump position		sh.: 30 Bl.:

VÖGELE Joseph Vögele AG

FR
←

- A,B
 4x FLANSCHHÄLFTE 3/4"/6000PSI 96.1299.1046
 2x O-RING 25,00x3,53 96.7214.0062
 8x SCHRAUBE M10x35 95.1031.0912

2065910

- 1x O-RING 150x4 96.3787.0062
 2x SCHRAUBE M16x30 95.1630.0933

M2
2042084

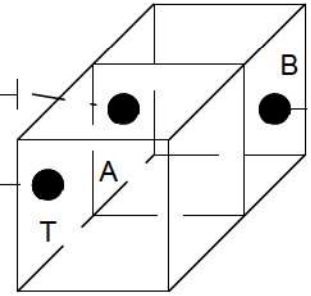

2065911

- GEV M18x1,5-15L
96.0315.0057

- 1x SCHELLE 96.6025.0185
 1x DECKPLATTE 96.8503.0185
 1x SCHRAUBE 95.0833.0933
 1x MUTTER 96.9503.0185

- 1x SCHELLE 96.5025.0185
 1x DECKPLATTE 96.8003.0185
 2x SCHRAUBE 95.0632.0933
 2x MUTTER 96.9501.0185

- A,B
 4x FLANSCHHÄLFTE 3/4"/6000PSI 96.1299.1046
 2x O-RING 25,00x3,53 96.7214.0062
 8x SCHRAUBE M10x35 95.1031.0912

- 1x O-RING 100x4 96.3259.0062
 2x SCHRAUBE M12x35 96.1231.0045

Q2
2043270

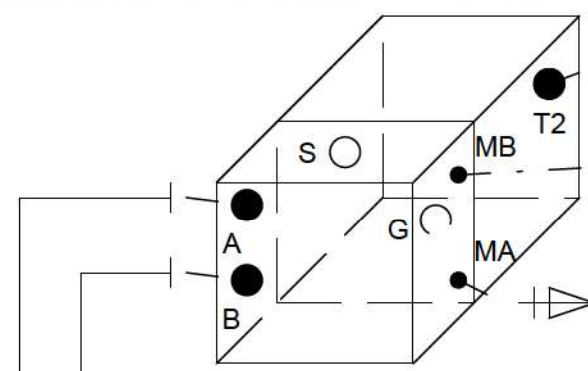

- GEV M22x1,5-15L
96.0366.0057

2065947

- MINIM. M12x1,5
96.2554.1000

- MINIM. M12x1,5
96.2554.1000

- 2x EWV16S
95.3160.3952

2065948

SA3
2057005

- 1x SCHELLE 96.6025.0185
 1x DECKPLATTE 96.8503.0185
 1x SCHRAUBE 95.0833.0933
 1x MUTTER 96.9503.0185

2065915

2065912

Fahrtrieb rechts
advance drive right

Schutzvermerk nach ISO 16016 beachten/Refer to protection notice ISO 16016

Modification	Date	Name	Date	Name	Machine Key Code:	Ident-No.:	Spot:	Plan
a					08.11	2173308 00		
b			07.10.09	Letz	0811 0409 - XXXX	Fahrtrieb advance drive		BL: 4 sh.: 30
c			gepr.					BL:
d								



Joseph Vögele AG

← FR

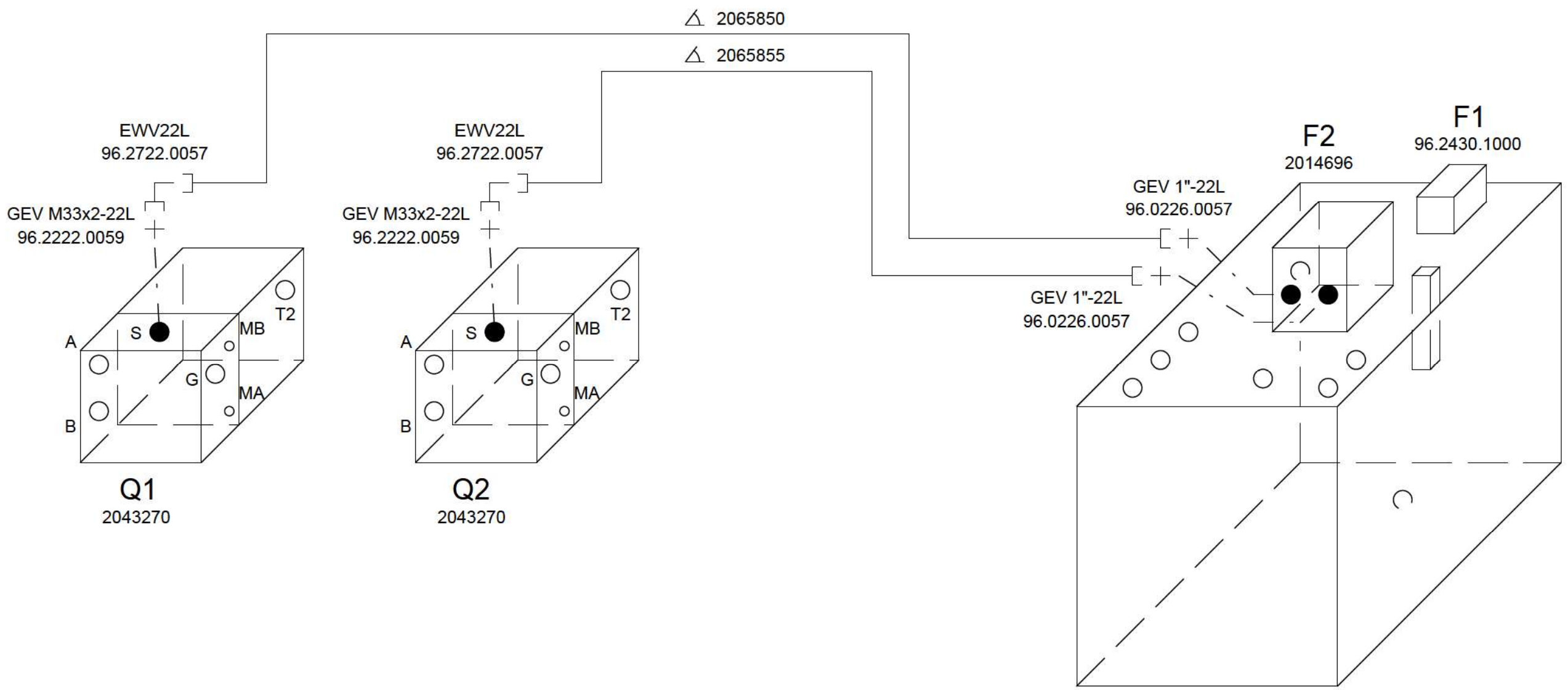

Einspeisung
feed

Schutzvermerk nach ISO 16016 beachten/Refer to protection notice ISO 16016

Modification	Date	Name	Date	Name	Machine Key Code:	Ident-No.:	Spot:	Plan
a					08.11	2173308 00		
b			07.10.09	Letz				
c					Serial-No.: 0811 0409 - XXXX	Designation: Fahrtrieb advance drive		Bl.: 5
d								sh.: 30 Bl.:

VÖGELE Joseph Vögele AG

2066204

FR
2046444

- 1x SCHELLE 96.5015.0185
- 1x DECKPLATTE 96.8002.0185
- 2x SCHRAUBE 95.0631.0933
- 2x MUTTER 96.9501.0185

- 2x SCHRAUBE M8x20 95.0820.0933
- 2x SCHEIBE 95.0084.7349

GEV M14x1,5-8L
96.0307.0057

ELV8L
96.2908.0057

SA3
2057005

2066171

- 3x GEV 1/4"-8L
96.0208.0057

- 1x ROHR 2009213
- 1x SCHELLE 3515.08.0195
- 1x SCHRAUBE 95.0420.0084
- 1x MUTTER 96.0004.0934
- 2x SCHEIBE 95.0004.0125
- 2x STOPFEN 2014457

Q2
2043270

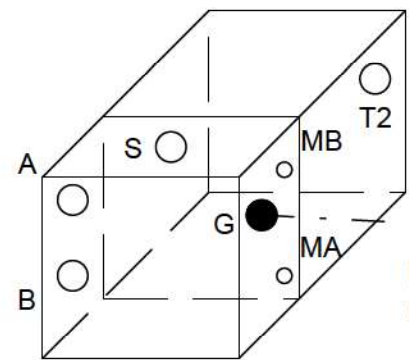

GEV M18x1,5-12L
96.0313.0057

REDV.12L/8L
96.1822.0060

34.1001.1050

EWV8L
96.2708.0057

ETV8L
96.3008.0057

MINIM. 8L
96.2552.1000

ST1
2043277

- 2x SCHRAUBE M6x50
95.0634.0933

2066172

GEV M14x1,5-8L
96.0307.0057

2066170

F1
96.2430.1000

F2
2014696

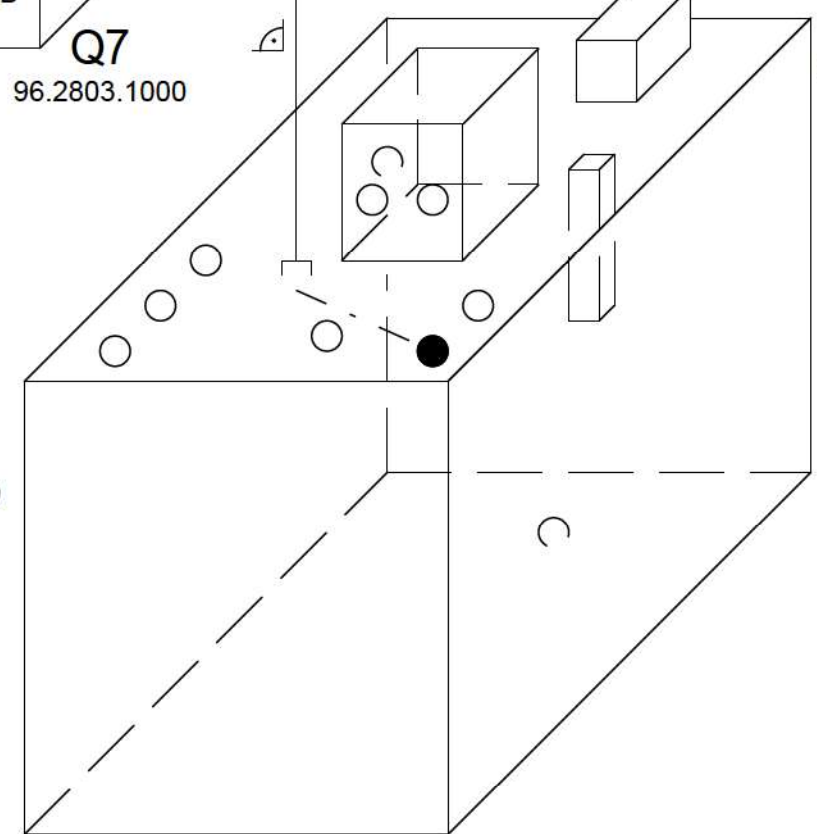

Bremse
brake

Schutzvermerk nach ISO 16016 beachten/Refer to protection notice ISO 16016

Modification	Date	Name	Date	Name	Machine Key Code:	Ident-No.:	Spot:	Plan
a					08.11	2173308 00		
b			07.10.09	Letz	0811 0409 - XXXX	Fahrertrieb advance drive		Bl.: 6
c			gepr.					sh.: 30
d								Bl.: 30

VÖGELE

Joseph Vögele AG

- 1x BLECH 2057432
- 1x SCHEIBE 95.0008.0125
- 1x SCHRAUBE M8x16 95.0816.0933
- 1x SCHELLE 96.5032.0185
- 1x DECKPLATTE 96.8005.0185
- 2x SCHRAUBE 95.0636.0933
- 2x MUTTER 95.0006.0934

FR
2041622

△ 2057672

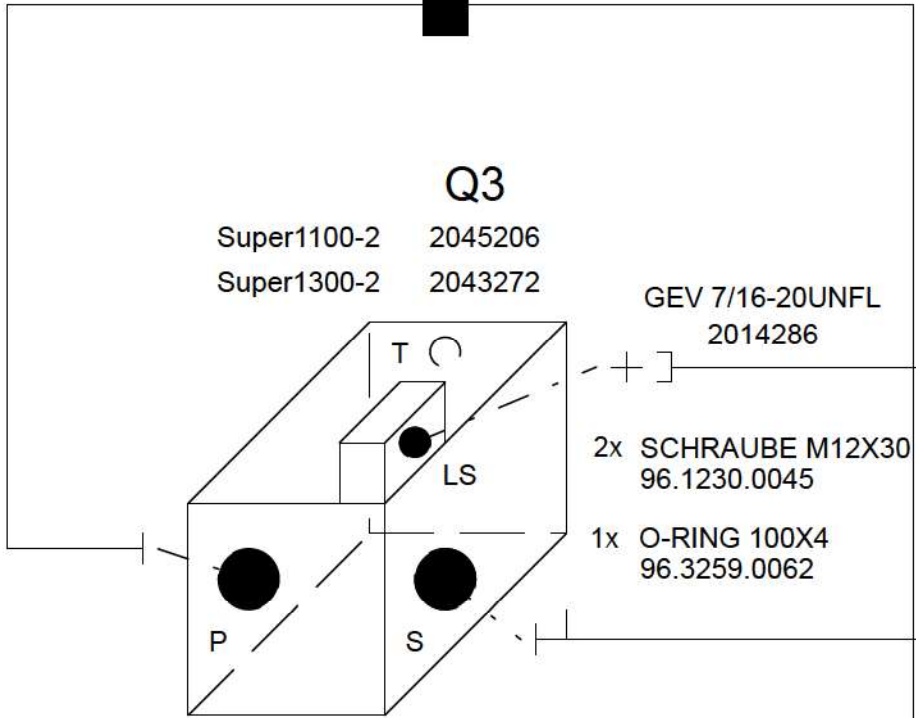

- Q3**
- Super1100-2 2045206
 - Super1300-2 2043272

GEV 7/16-20UNFL
2014286

- 2x SCHRAUBE M12X30
96.1230.0045
- 1x O-RING 100X4
96.3259.0062

- P**
- 2x FLANSCHHÄLFTE 1"-3000PSI 96.1217.1024
 - 1x O-RING 32,92x3,53 96.7219.0062
 - 4x SCHRAUBE M10x35 95.1031.0912
- S**
- 2x FLANSCHHÄLFTE 1 1/2"-3000PSI 96.1216.1334
 - 1x O-RING 47,22x3,53 96.7225.0062
 - 4x SCHRAUBE M12x35 95.1231.0912

2061560

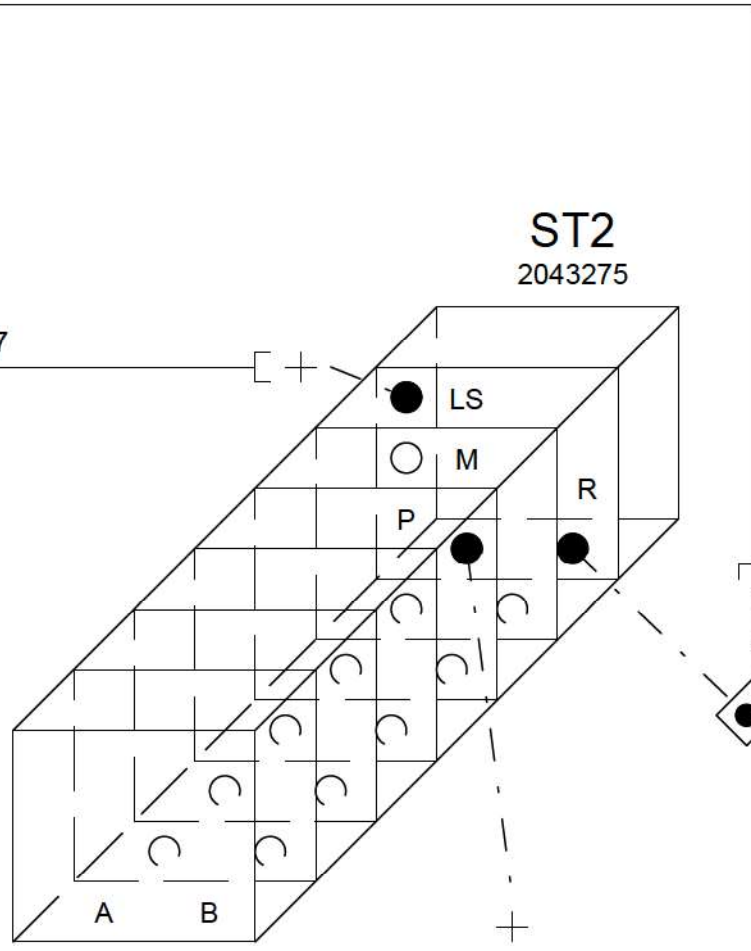

ST2
2043275

2066167

SA2
2067693

EWV25S
96.2825.0057

Schutzvermerk nach ISO 16016 beachten/Refer to protection notice ISO 16016

Modification	Date	Name	Date	Name	Machine Key Code:	Ident-No.:	Spot:	Plan
a					08.11	2173308 00		
b			07.10.09	Letz				
c					0811 0409 - XXXX	Verteilerschnecke-Förderband auger-conveyor		Bl.: 7
d								sh.: 30 Bl.:

VÖGELE Joseph Vögele AG

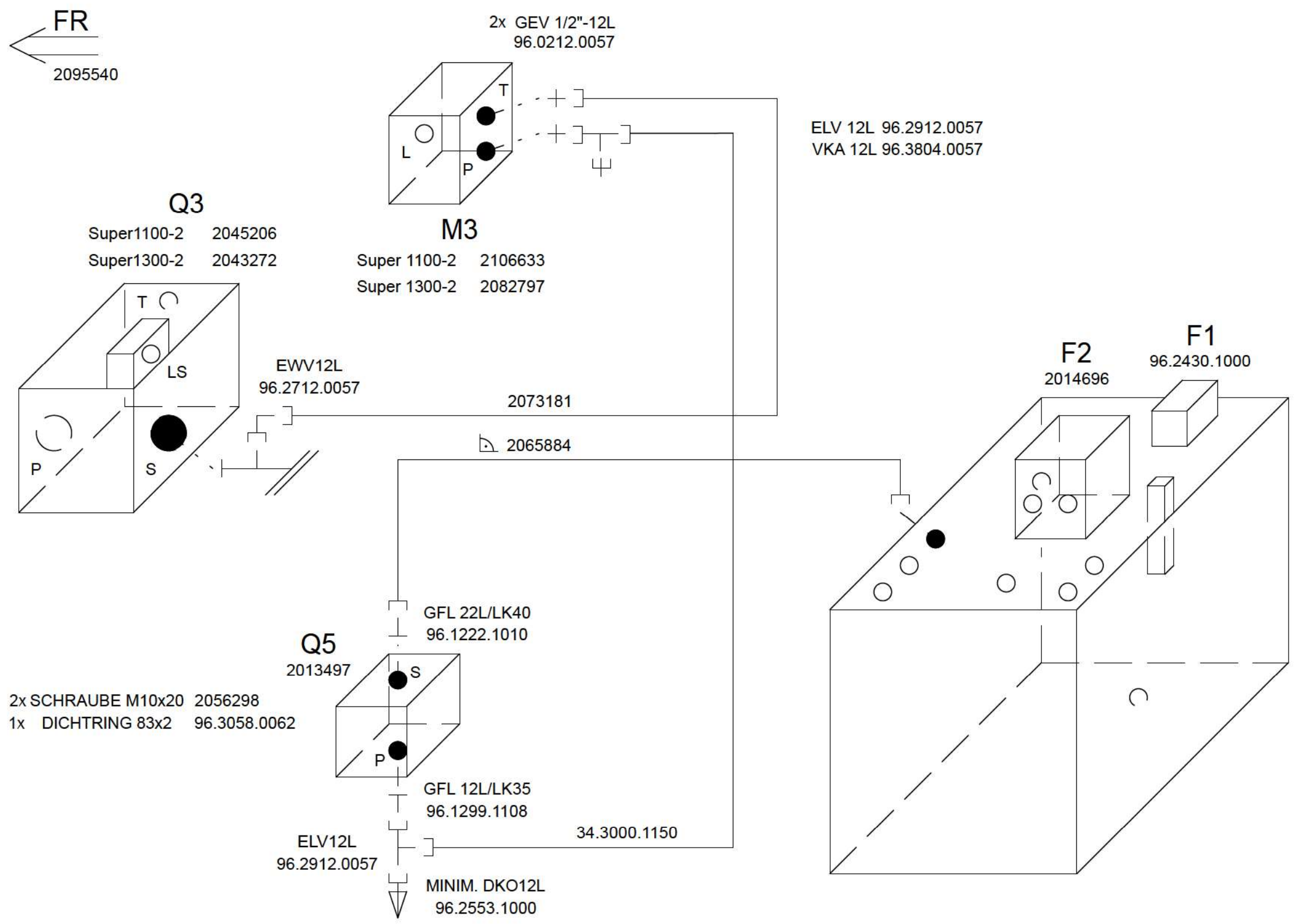

Einspeisung
feed

Schutzvermerk nach ISO 16016 beachten/Refer to protection notice ISO 16016

Modification	Date	Name	Date	Name	Machine Key Code:	Ident-No.:	Spot:	Plan
a					08.11	2173308 00		
b			07.10.09	Letz				
c					0811 0409 - XXXX	Verteilerschnecke-Förderband		Bl.: 8
d						auger-conveyor		sh.: 30 Bl.:

VÖGELE Joseph Vögele AG

FR ←

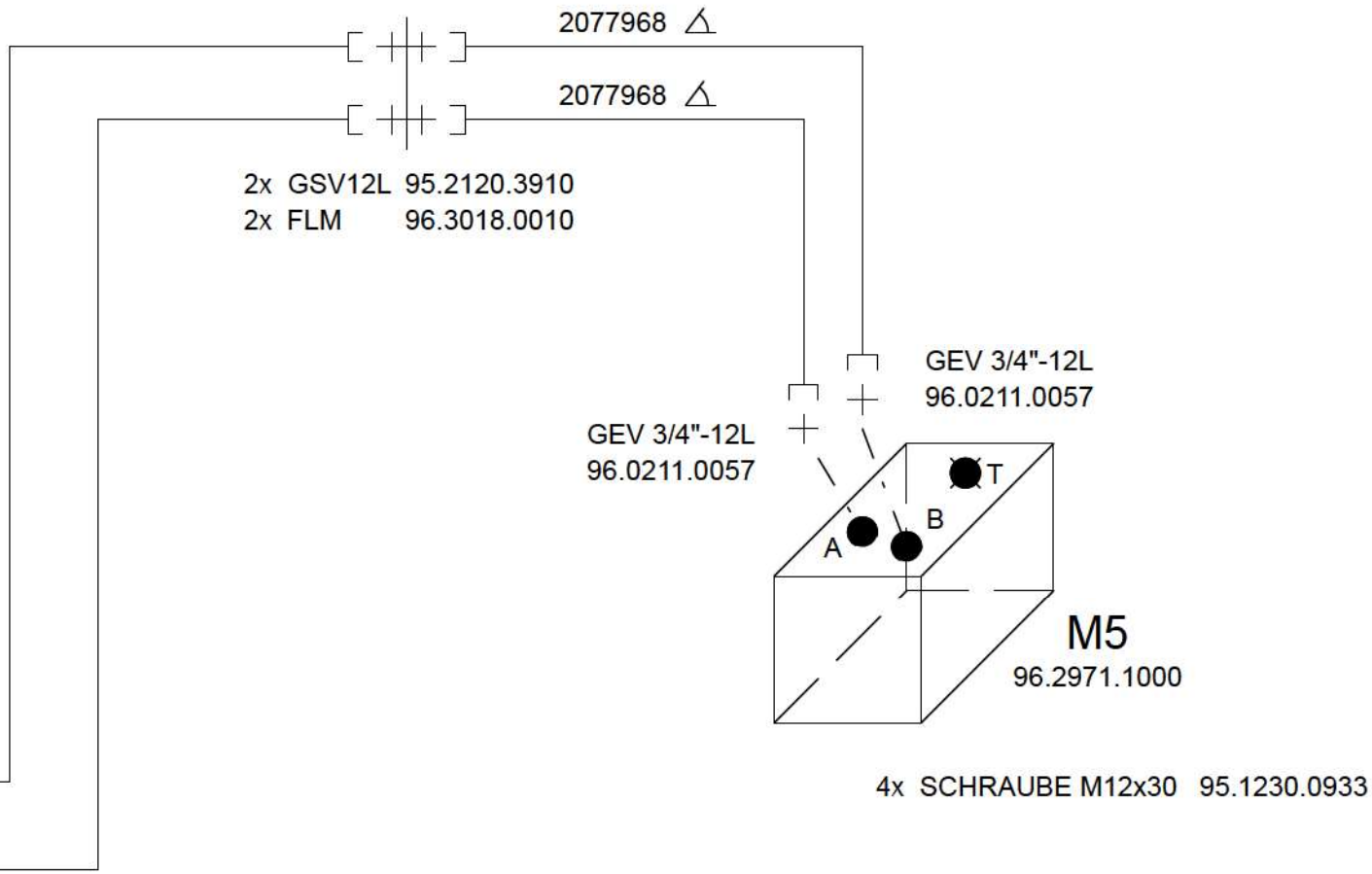
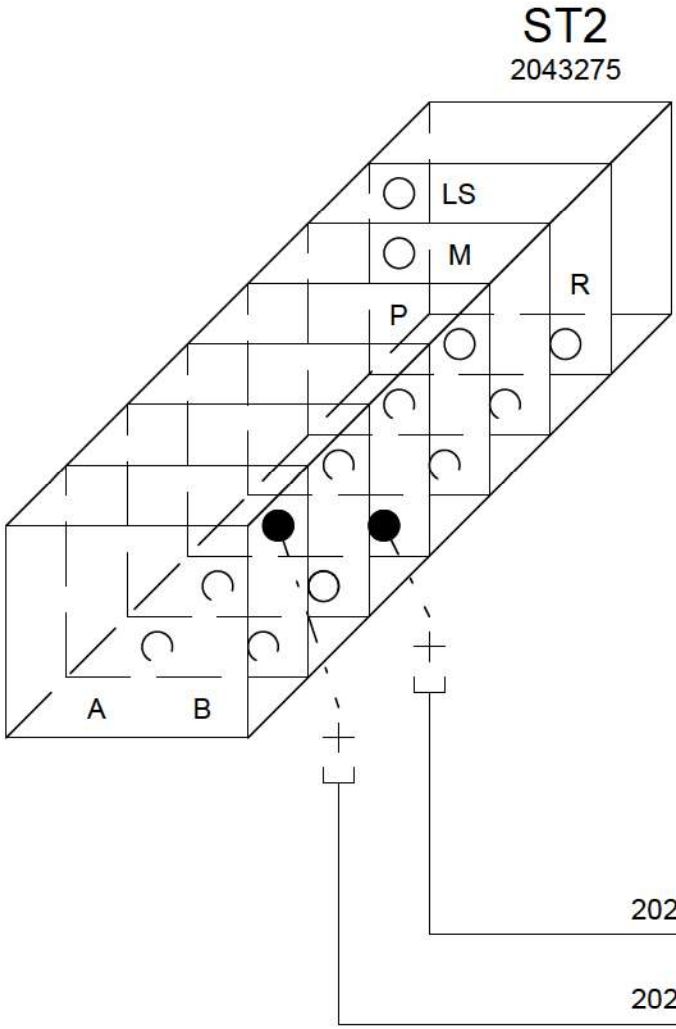

links
left

Schutzvermerk nach ISO 16016 beachten/Refer to protection notice ISO 16016

Modification	Date	Name	Date	Name	 Joseph Vögele AG	Machine Key Code:	Ident-No.:	Spot:	Plan	
a							08.11	2173308 00		
b			07.10.09	Letz						
c										
d						0811 0409 - XXXX	Verteilerschnecke auger		Bl.: 9 sh.: 30 Bl.:	

FR ←

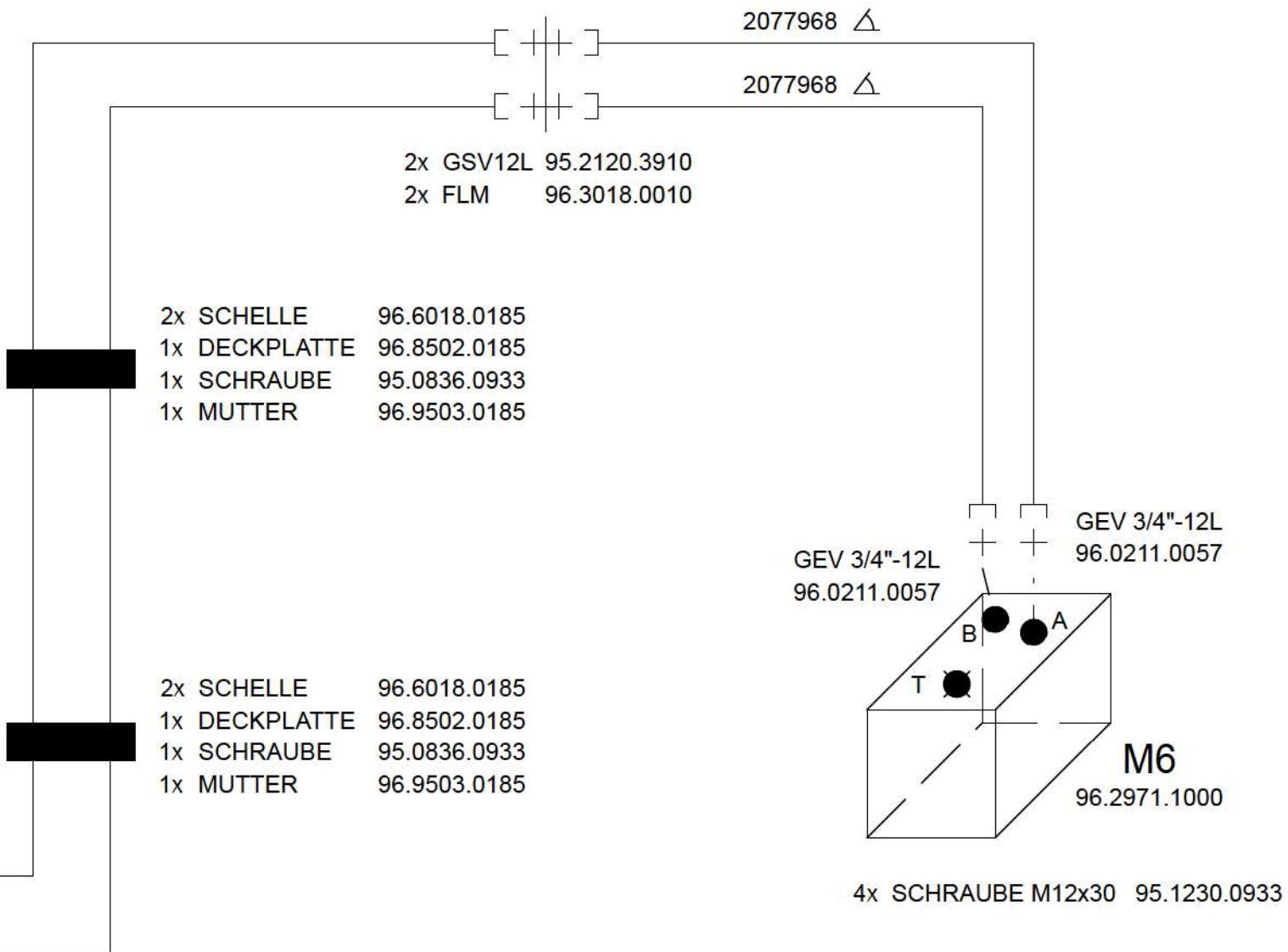
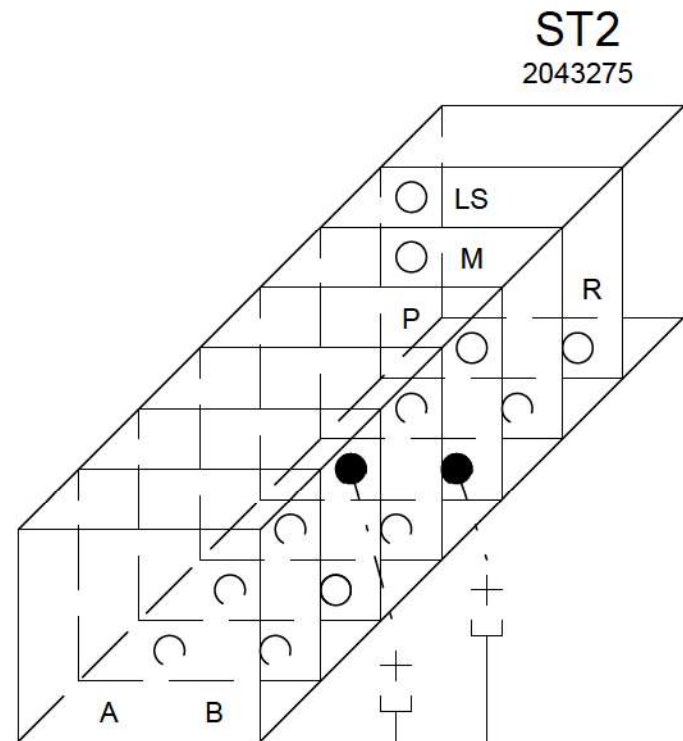

rechts
right

Schutzvermerk nach ISO 16016 beachten/Refer to protection notice ISO 16016

Modification	Date	Name	Date	Name	Machine Key Code:	Ident-No.:	Spot:	Plan
a					08.11	2173308 00		
b			07.10.09	Letz				
c					0811 0409 - XXXX	Verteilerschnecke auger		Bl.: 10
d								sh.: 30 Bl.:

VÖGELE Joseph Vögele AG

FR
←

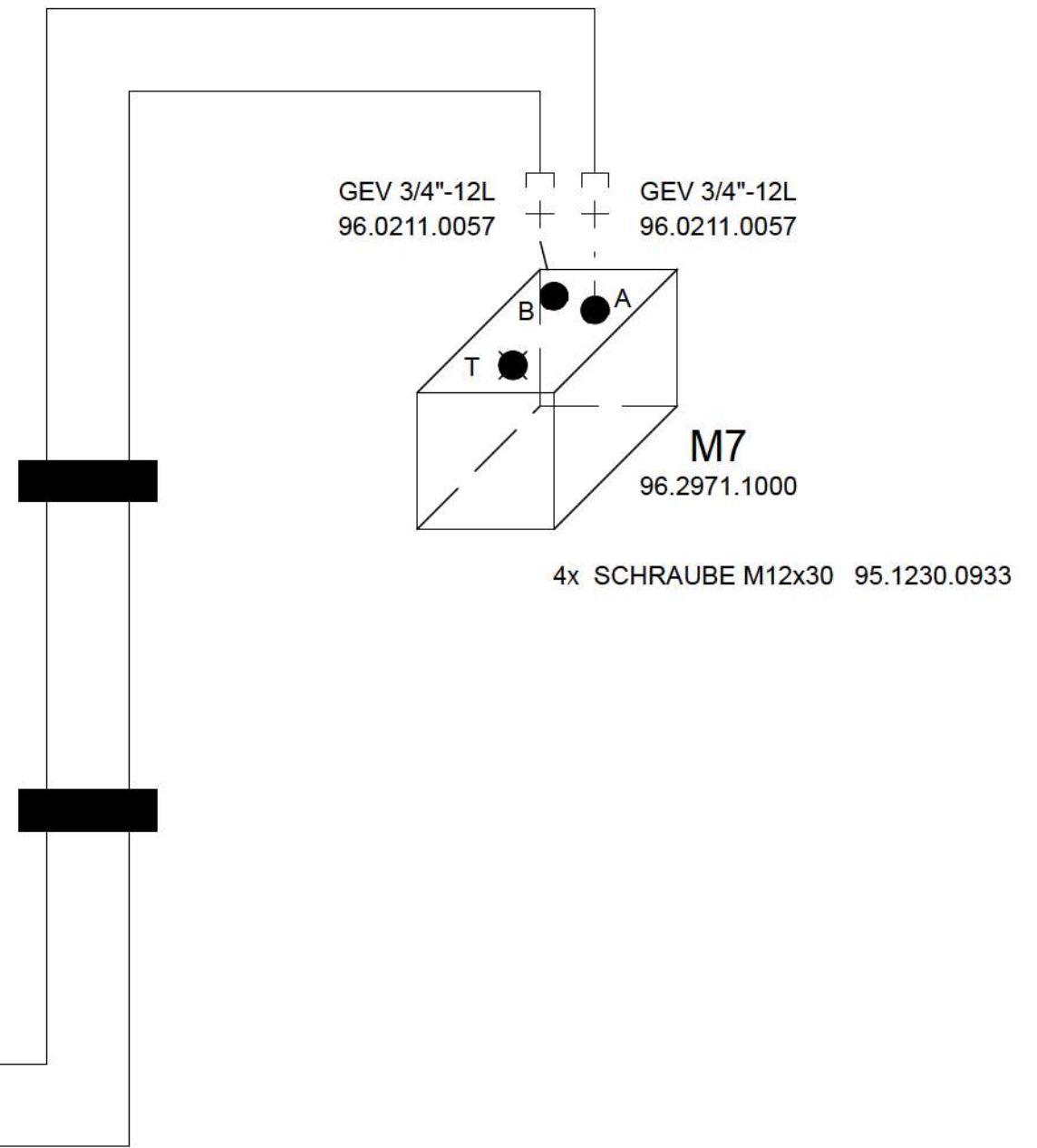
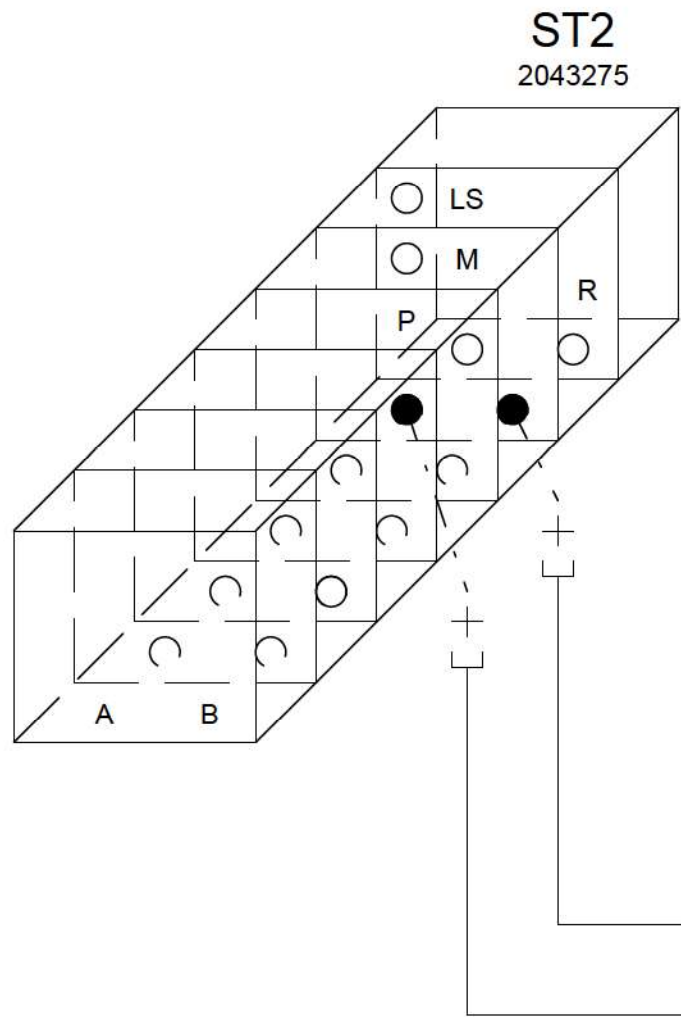

rechts
right

Schutzvermerk nach ISO 16016 beachten/Refer to protection notice ISO 16016

Modification	Date	Name	Date	Name	Machine Key Code:	Ident-No.:	Spot:	Plan
a					08.11	2173308 00		
b			07.10.09	Letz				
c					Serial-No.: 0811 0409 - XXXX	Designation: Kratzerband conveyor		Bl.: 12
d								sh.: 30 Bl.:

VÖGELE Joseph Vögele AG

Schutzvermerk nach ISO 16016 beachten/Refer to protection notice ISO 16016

1 2 3 4 5 6 7 8

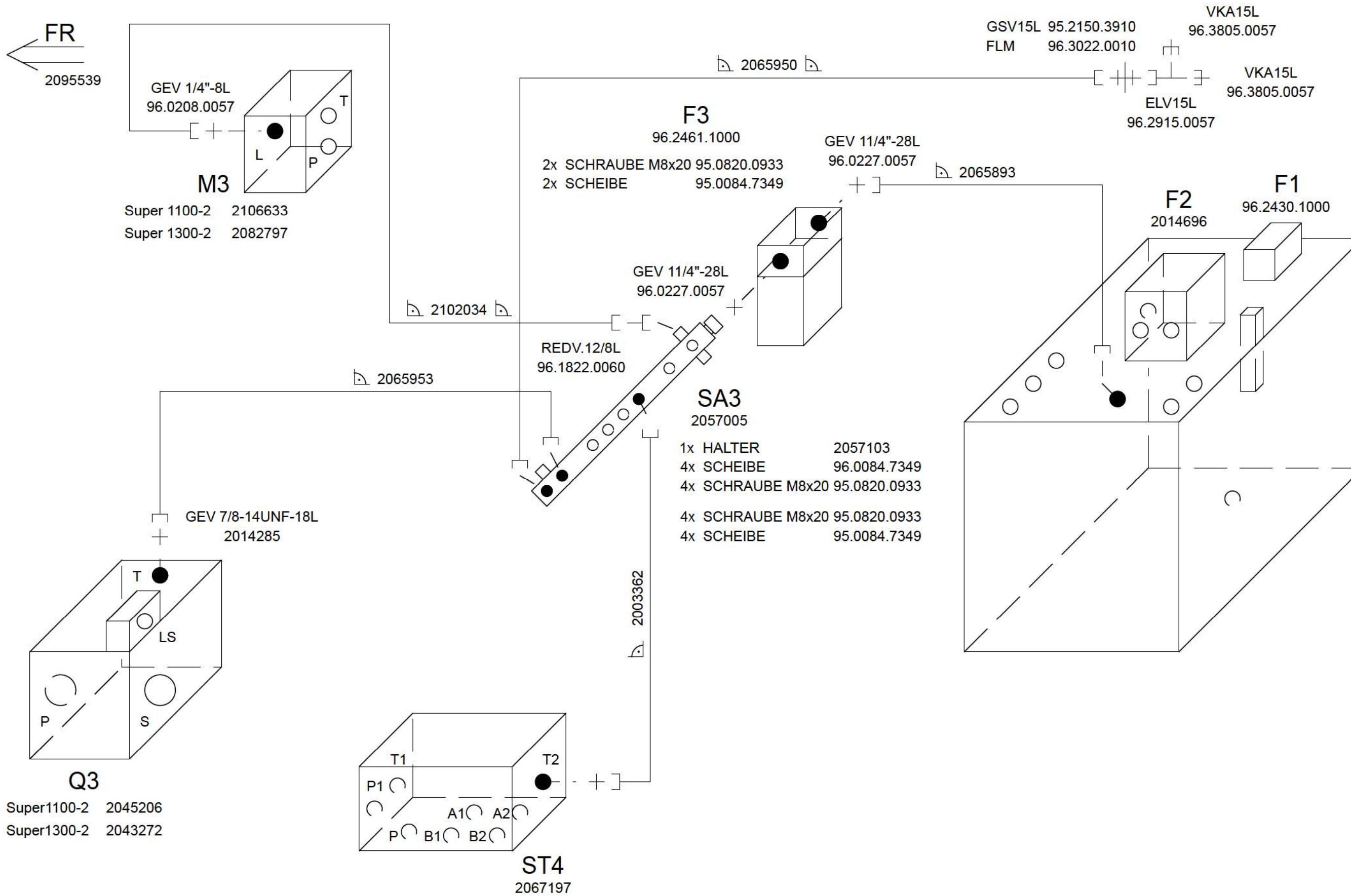

Modification	Date	Name	Date	Name	Machine Key Code:	Ident-No.:	Spot:	Plan
a					08.11	2173308 00		
b			07.10.09	Letz				
c			gepr.		0811 0409 - XXXX	Lecköl leakage oil		Bl.: 13 sh.: 30
d								Bl.: 30

VÖGELE Joseph Vögele AG

Schutzvermerk nach ISO 16016 beachten/Refer to protection notice ISO 16016

1 2 3 4 5 6 7 8

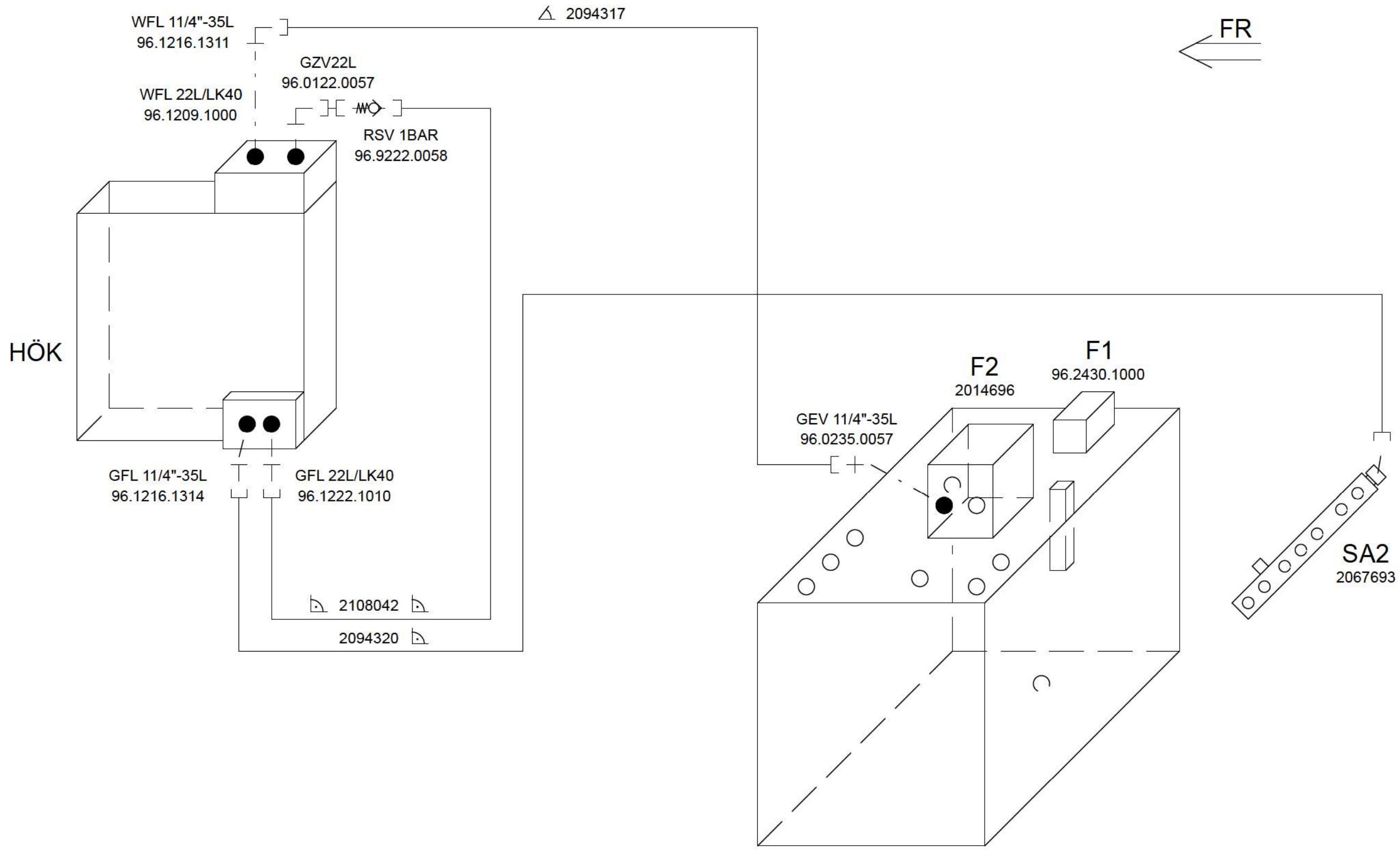

Modification	Date	Name	Date	Name	Machine Key Code:	Ident-No.:	Spot:	Plan
a					08.11	2173308 00		
b			07.10.09	Letz				
c			gepr.		0811 0409 - XXXX	Rücklauf return line		Bl.: 14
d								sh.: 30 Bl.:

VÖGELE Joseph Vögele AG

Schutzvermerk nach ISO 16016 beachten/Refer to protection notice ISO 16016

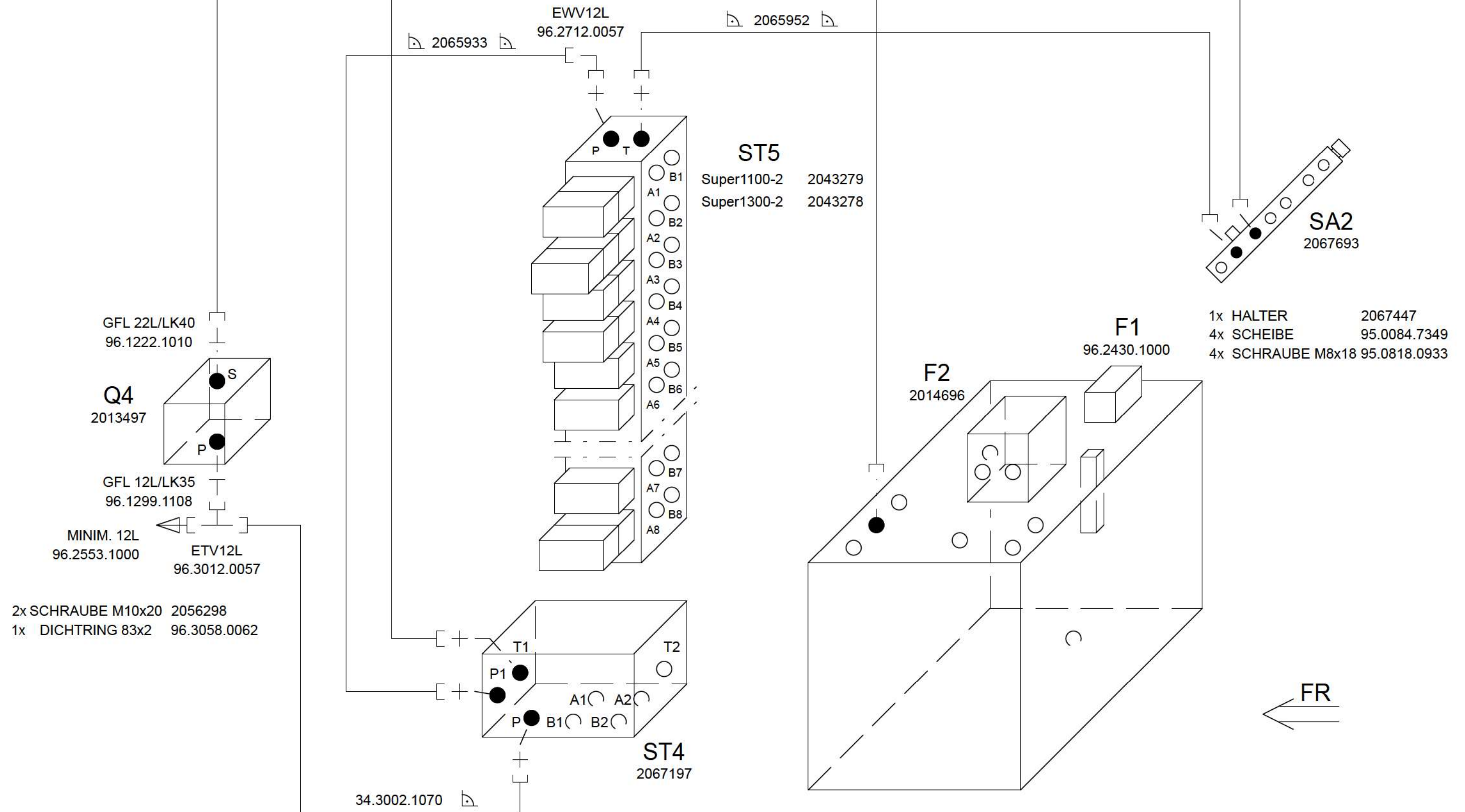

Modification	Date	Name	Date	Name	Machine Key Code:	Ident-No.:	Spot:	Plan
a					08.11	2173308 00		
b			07.10.09	Letz				
c					0811 0409 - XXXX	Zylinderfunktionen cylinder functions		Bl.: 15 sh.: 30
d								Bl.: sh.: 30

VÖGELE Joseph Vögele AG

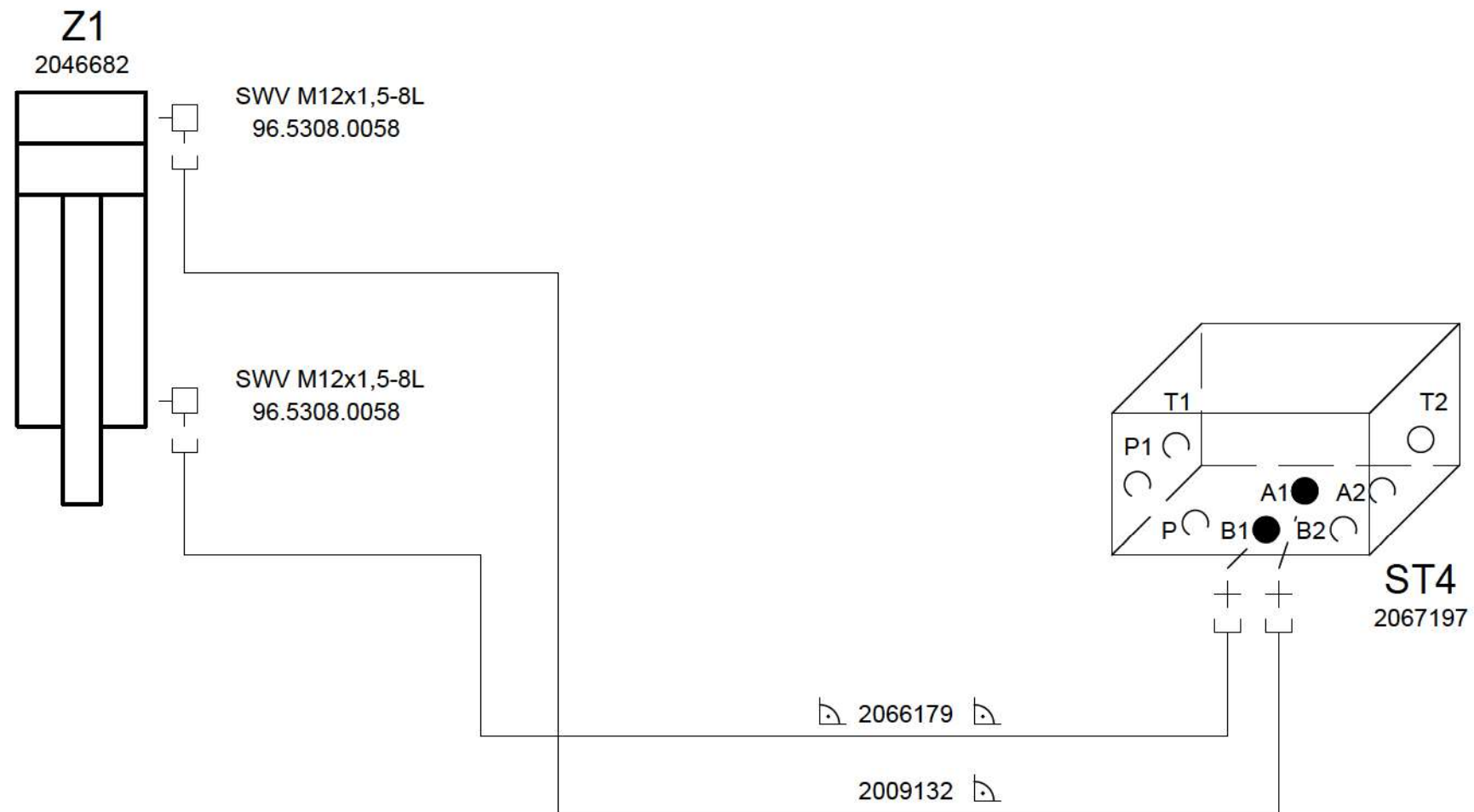

links
left

Schutzvermerk nach ISO 16016 beachten/Refer to protection notice ISO 16016

Modification	Date	Name	Date	Name	Machine Key Code:	Ident-No.:	Spot:	Plan
a					08.11	2173308 00		
b			07.10.09	Letz				
c					Serial-No.: 0811 0409 - XXXX	Designation: Nivellierung levelling system		Bl.: 16
d								sh.: 30 Bl.:

VÖGELE Joseph Vögele AG

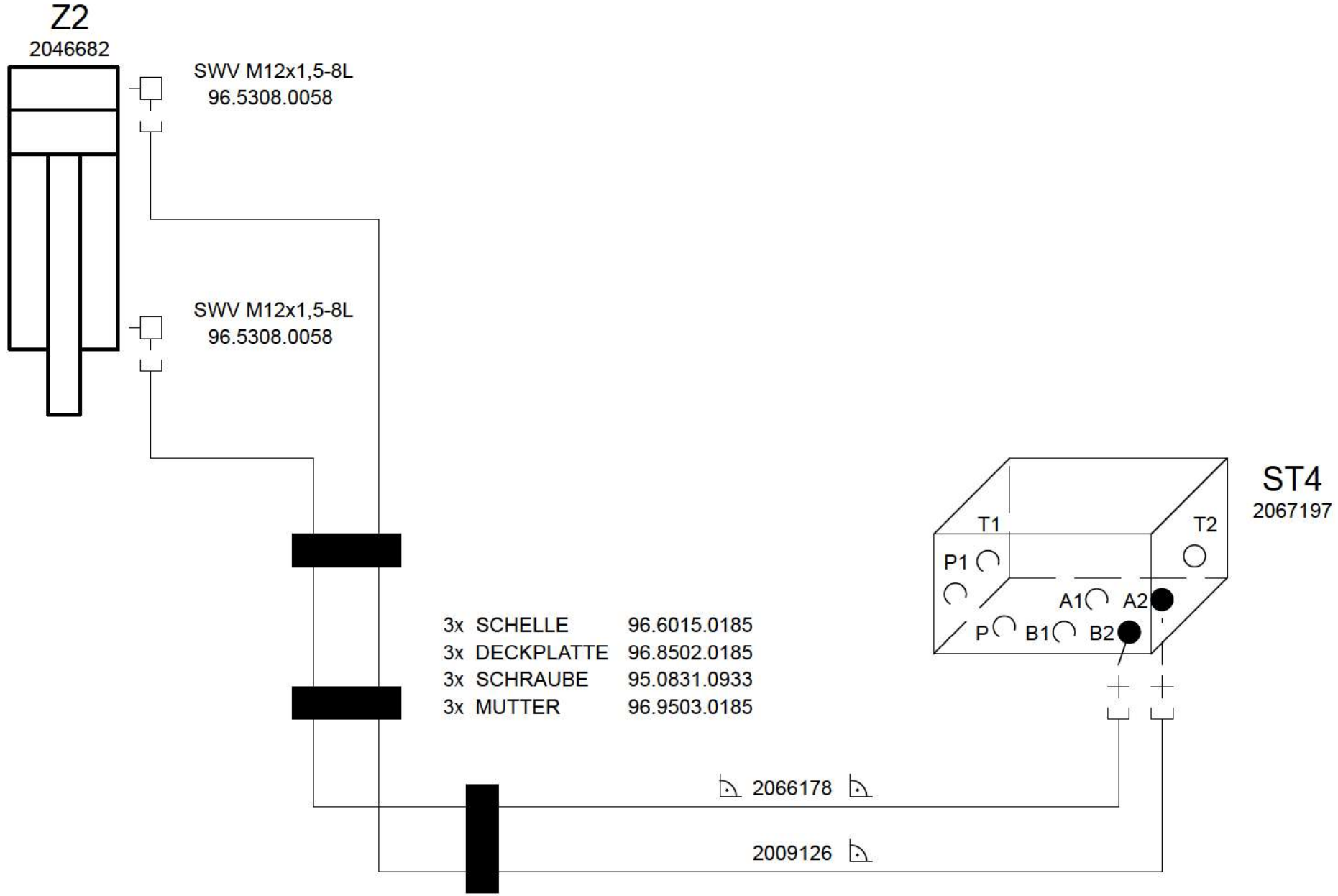

- 3x SCHELLE 96.6015.0185
- 3x DECKPLATTE 96.8502.0185
- 3x SCHRAUBE 95.0831.0933
- 3x MUTTER 96.9503.0185

← FR

rechts
right

Schutzvermerk nach ISO 16016 beachten/Refer to protection notice ISO 16016

Modification	Date	Name	Date	Name	Machine Key Code:	Ident-No.:	Spot:	Plan
a					08.11	2173308 00		
b			07.10.09	Letz				
c					0811 0409 - XXXX	Designation: Nivellierung levelling system		Bl.: 17
d								sh.: 30 Bl.:

VÖGELE Joseph Vögele AG

FR ←

ST5
 Super1100-2 2043279
 Super1300-2 2043278

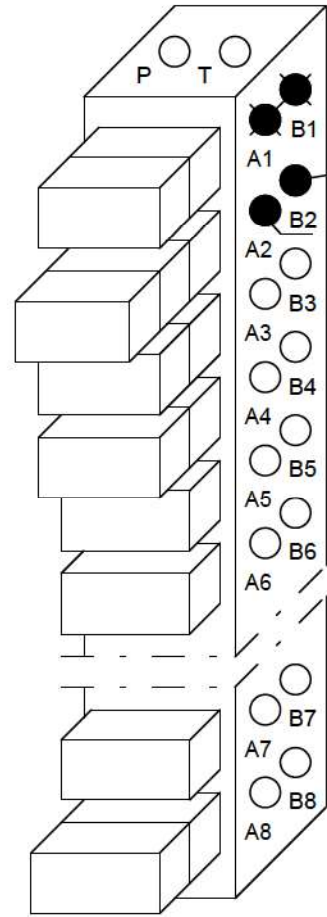

- 2x SCHELLE 96.6018.0185
- 1x DECKPLATTE 96.8502.0185
- 1x SCHRAUBE 95.0836.0933
- 1x MUTTER 96.9503.0185

Z6
2046682

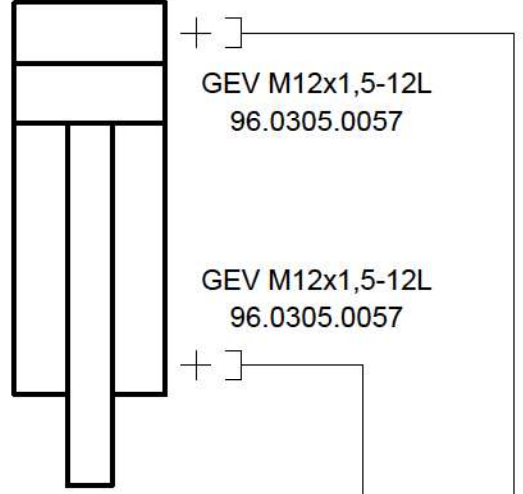

- 34.3002.1075
- 34.3002.1075
- 34.3002.1050
- 34.3002.1050

- 2x GSV12L 95.2120.3910
- 2x FLM 96.3018.0010

TV12L
95.2120.3908

- 34.3002.1105
- 34.3002.1105

TV12L
95.2120.3908

- 2x GSV12L 95.2120.3910
- 2x FLM 96.3018.0010

- 34.3002.1075
- 34.3002.1075
- 34.3002.1050
- 34.3002.1050

- 2x SCHELLE 96.6018.0185
- 1x DECKPLATTE 96.8502.0185
- 1x SCHRAUBE 95.0836.0933
- 1x MUTTER 96.9503.0185

Z5
2046682

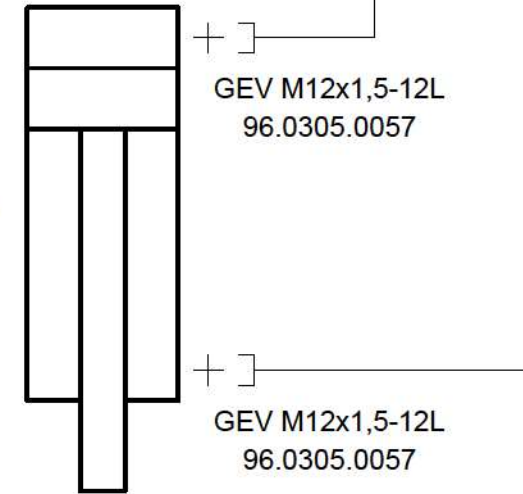

Schutzvermerk nach ISO 16016 beachten/Refer to protection notice ISO 16016

Modification	Date	Name	Date	Name	Machine Key Code:	Ident-No.:	Spot:	Plan
a					08.11	2173308 00		
b			07.10.09	Letz	0811 0409 - XXXX	Bohle heben/senken raising/lowering screed		Bl.: 18 sh.: 30
c								
d								

VÖGELE Joseph Vögele AG

FR ←

ST5
 Super1100-2 2043279
 Super1300-2 2043278

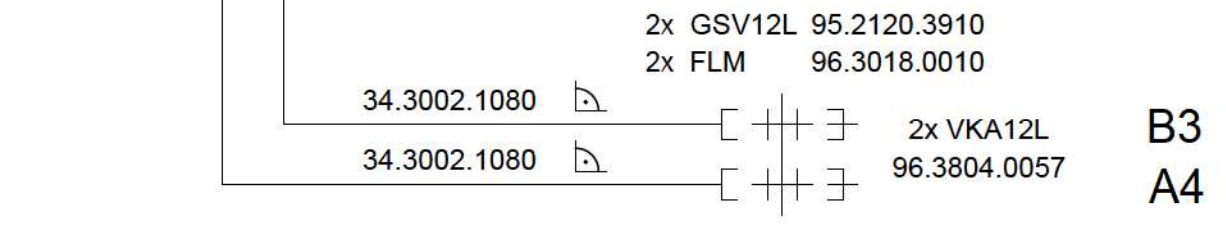
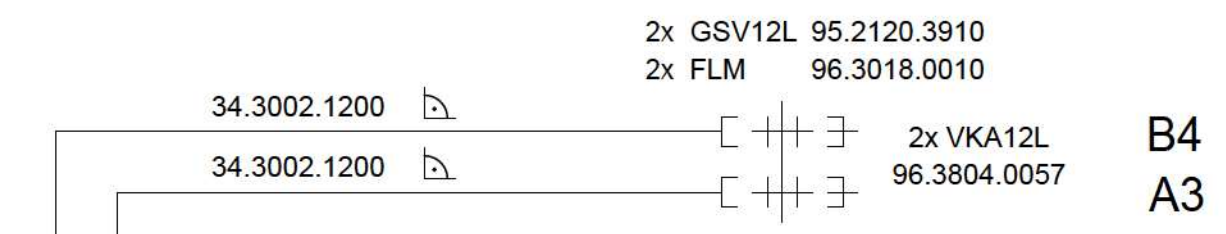
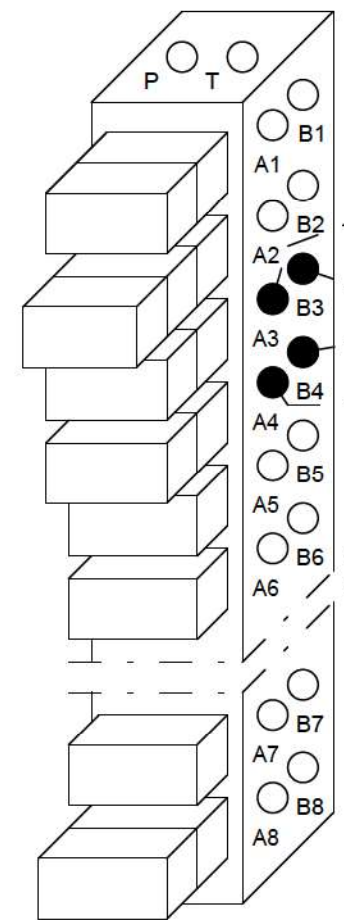

ein/ausfahren
 retract/extend

Schutzvermerk nach ISO 16016 beachten/Refer to protection notice ISO 16016

Modification	Date	Name	Date	Name	Machine Key Code:	Ident-No.:	Spot:	Plan
a					08.11	2173308 00		
b			07.10.09	Letz				
c			gepr.		Serial-No.: 0811 0409 - XXXX	Designation: Bohle screed		Bl.: 19
d								sh.: 30 Bl.:

VÖGELE Joseph Vögele AG

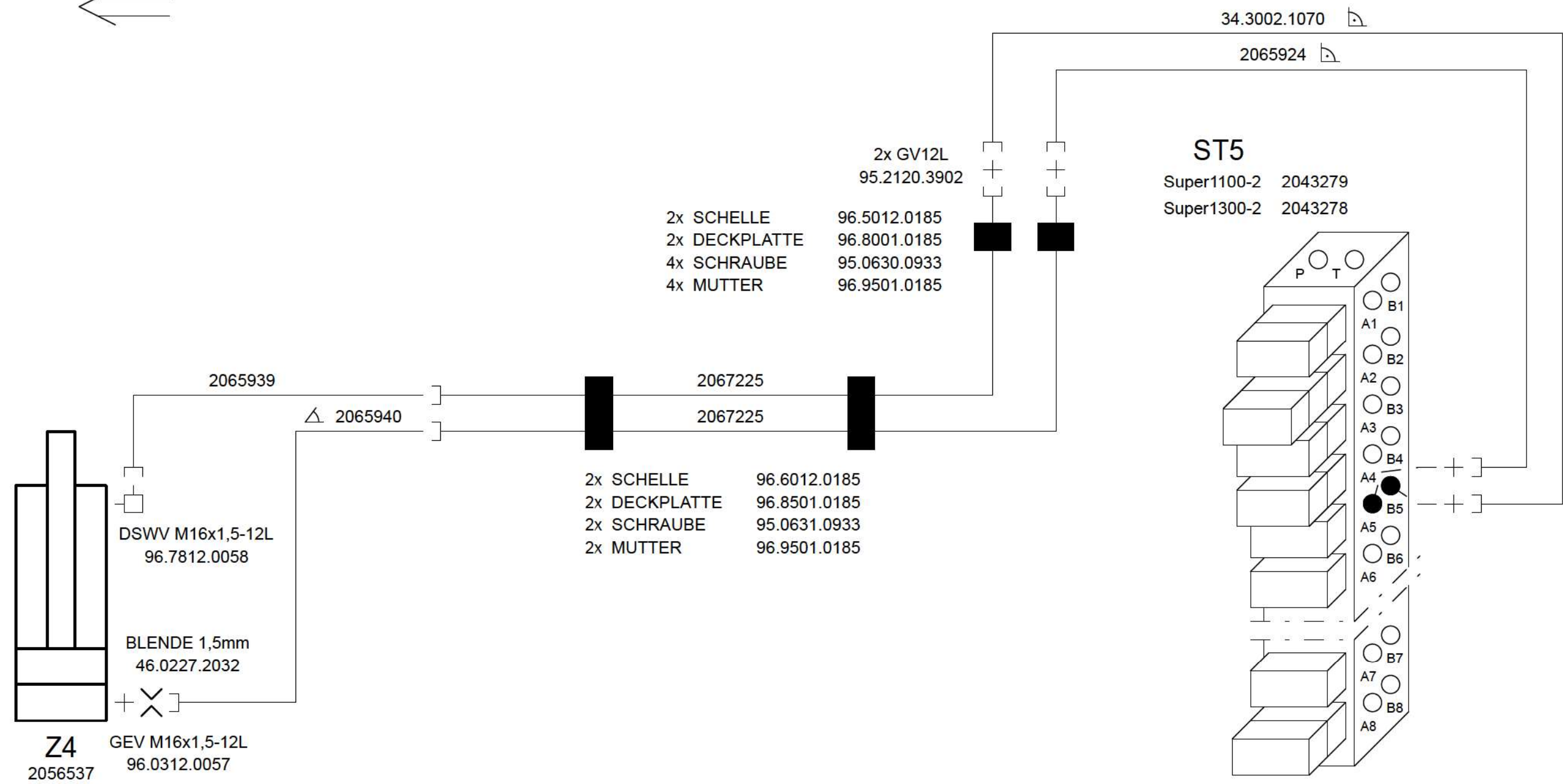
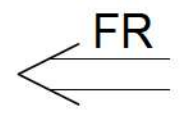

Schutzvermerk nach ISO 16016 beachten/Refer to protection notice ISO 16016

Modification	Date	Name	Date	Name	Machine Key Code:	Ident-No.:	Spot:	Plan
a					08.11	2173308 00		
b			07.10.09	Letz				
c					0811 0409 - XXXX	Bunkerwand links		Bl.: 20
d						hopper side left side		sh.: 30 Bl.:



Joseph Vögele AG

Schutzvermerk nach ISO 16016 beachten/Refer to protection notice ISO 16016

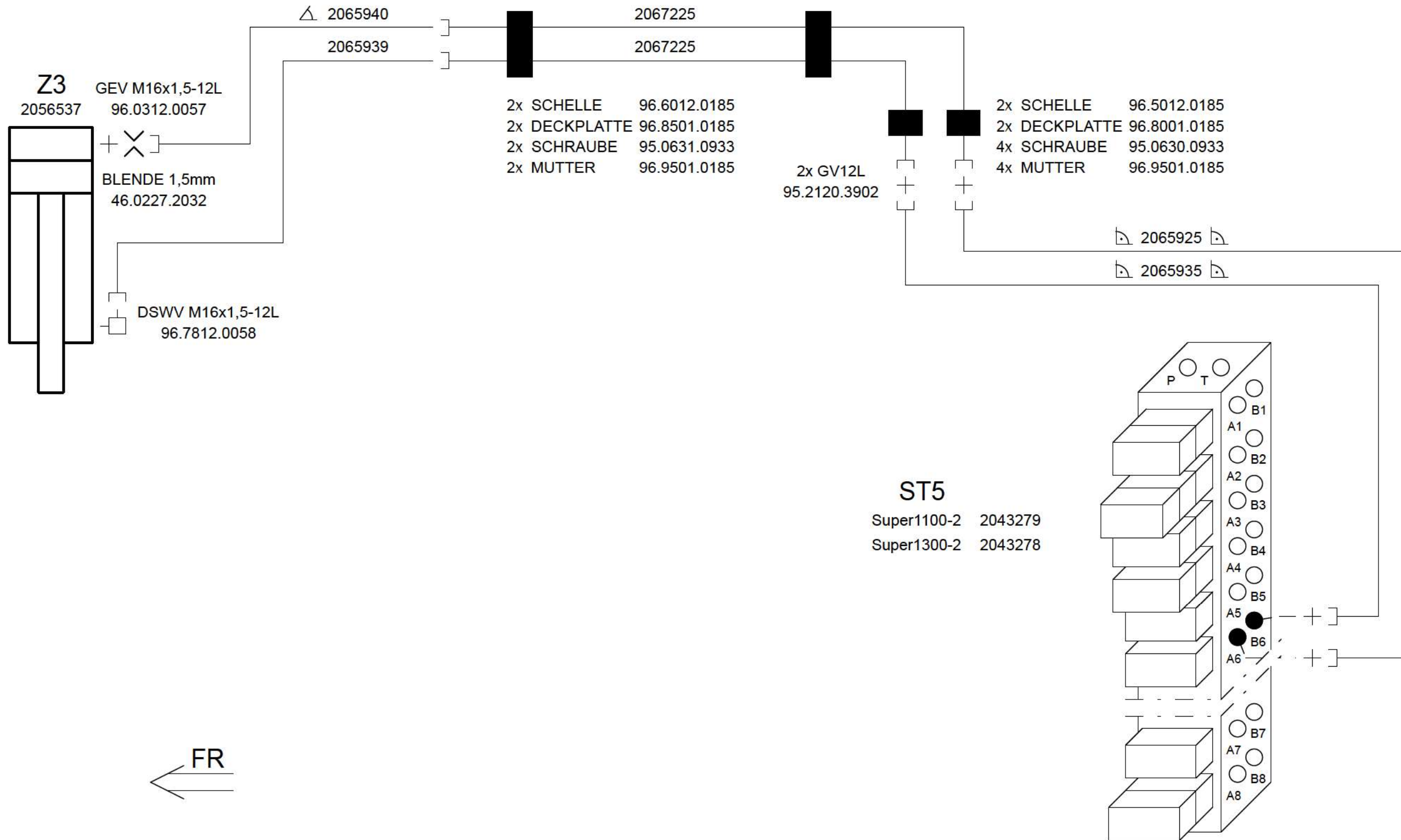

Modification	Date	Name	Date	Name	Machine Key Code:	Ident-No.:	Spot:	Plan
a					08.11	2173308 00		
b			07.10.09	Letz				
c			gepr.					
d								

VÖGELE	Joseph Vögele AG	Machine Key Code:	08.11	Ident-No.:	2173308 00	Spot:		Plan
		Serial-No.:	0811 0409 - XXXX	Designation:	Bunkerwand rechts hopper side right side	Bl.:	21	sh.:

Schutzvermerk nach ISO 16016 beachten/Refer to protection notice ISO 16016

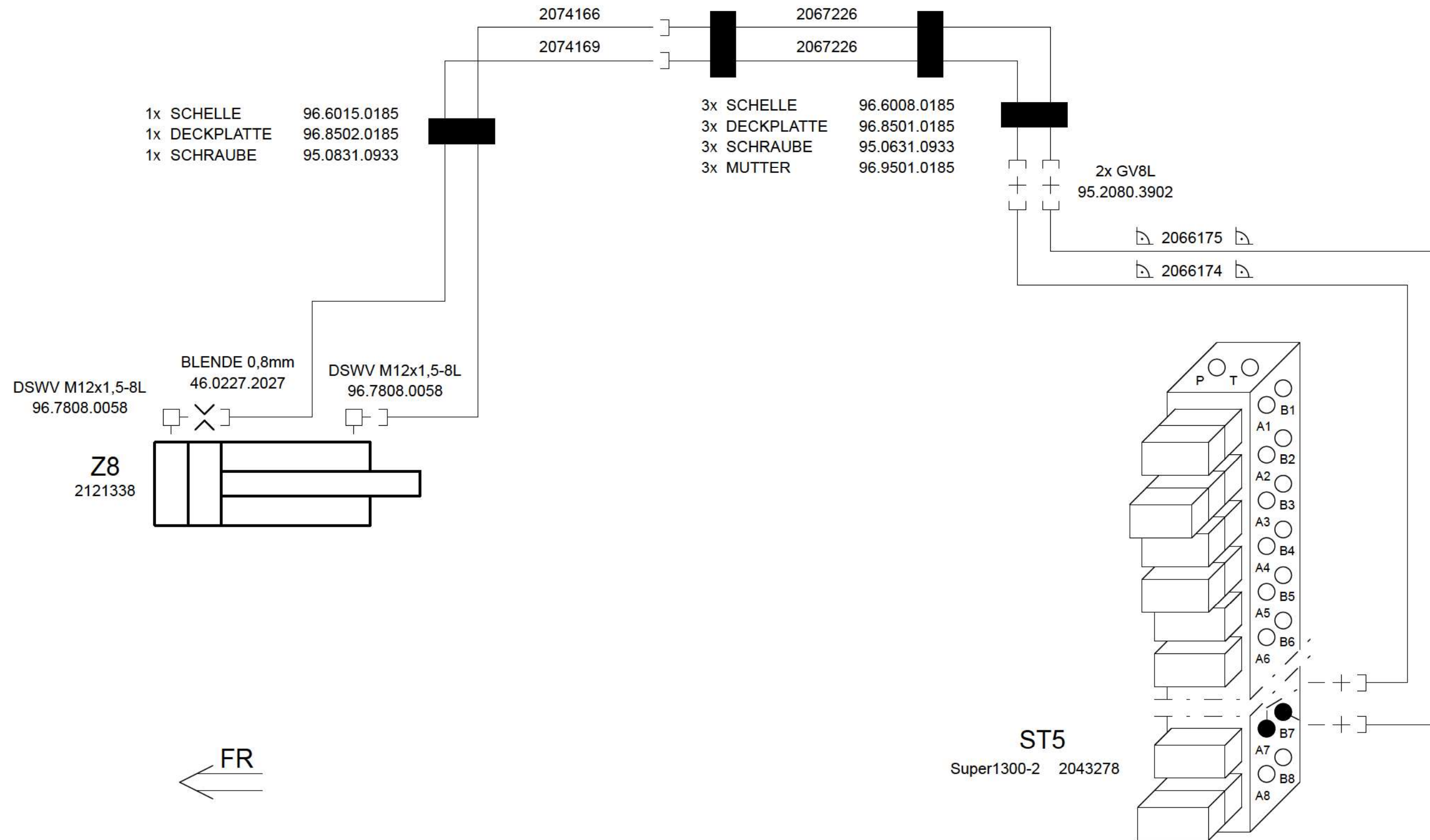

Modification	Date	Name	Date	Name	Machine Key Code:	Ident-No.:	Spot:	Plan
a					08.11	2173308 00		
b			07.10.09	Letz				
c					0811 0409 - XXXX	Klappe flap		Bl.: 22
d								sh.: 30 Bl.:

VÖGELE Joseph Vögele AG

Schutzvermerk nach ISO 16016 beachten/Refer to protection notice ISO 16016

1 2 3 4 5 6 7 8

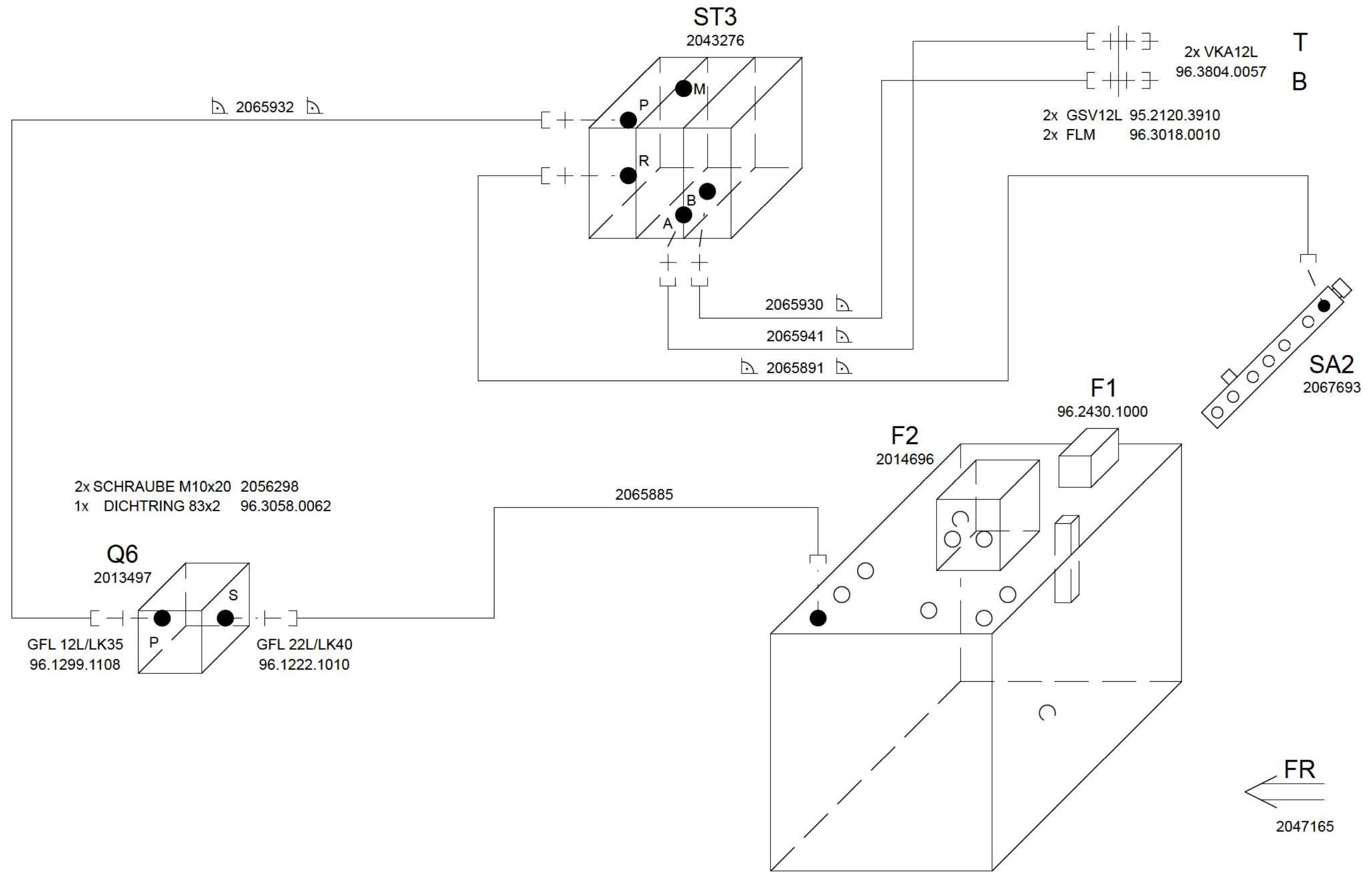

Modification	Date	Name	Date	Name	Machine Key Code:	Ident-No.:	Spot:	Plan
a					08.11	2173308 00		
b			07.10.09	Letz				
c					0811 0409 - XXXX	Designation: Tamper tamper		Bl.: 24
d								sh.: 30 Bl.:

VÖGELE Joseph Vögele AG

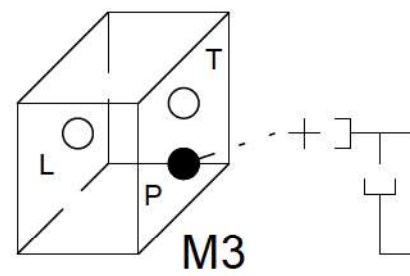

M3
 Super 1100-2 2106633
 Super 1300-2 2082797

ST6
 2045265

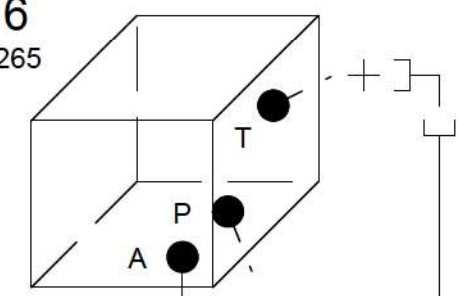

EWV 12L
 96.2712.0057

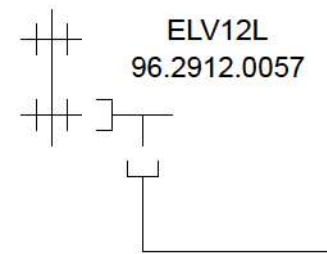

ELV12L
 96.2912.0057

SPIRALSCHLAUCH 0,8m
 3515.07.4560

2065938

2108024

2077941

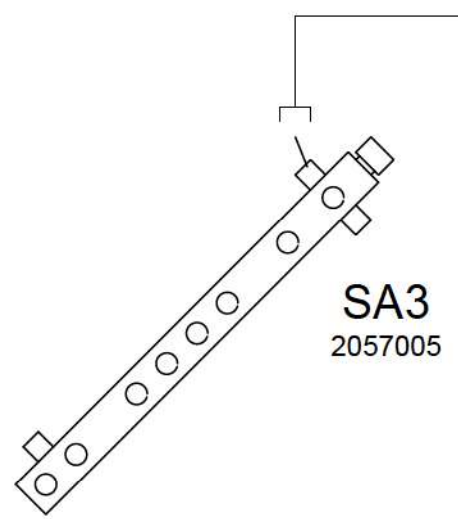

SA3
 2057005

FR
 2095542

Schutzvermerk nach ISO 16016 beachten/Refer to protection notice ISO 16016

Modification	Date	Name	Date	Name	Machine Key Code:	Ident-No.:	Spot:	Plan
a					08.11	2173308 00		
b			07.10.09	Letz				
c					0811 0409 - XXXX	Bohlenentlastung screed assist		Bl.: 25 sh.: 30
d								Bl.:

VÖGELE Joseph Vögele AG

← FR

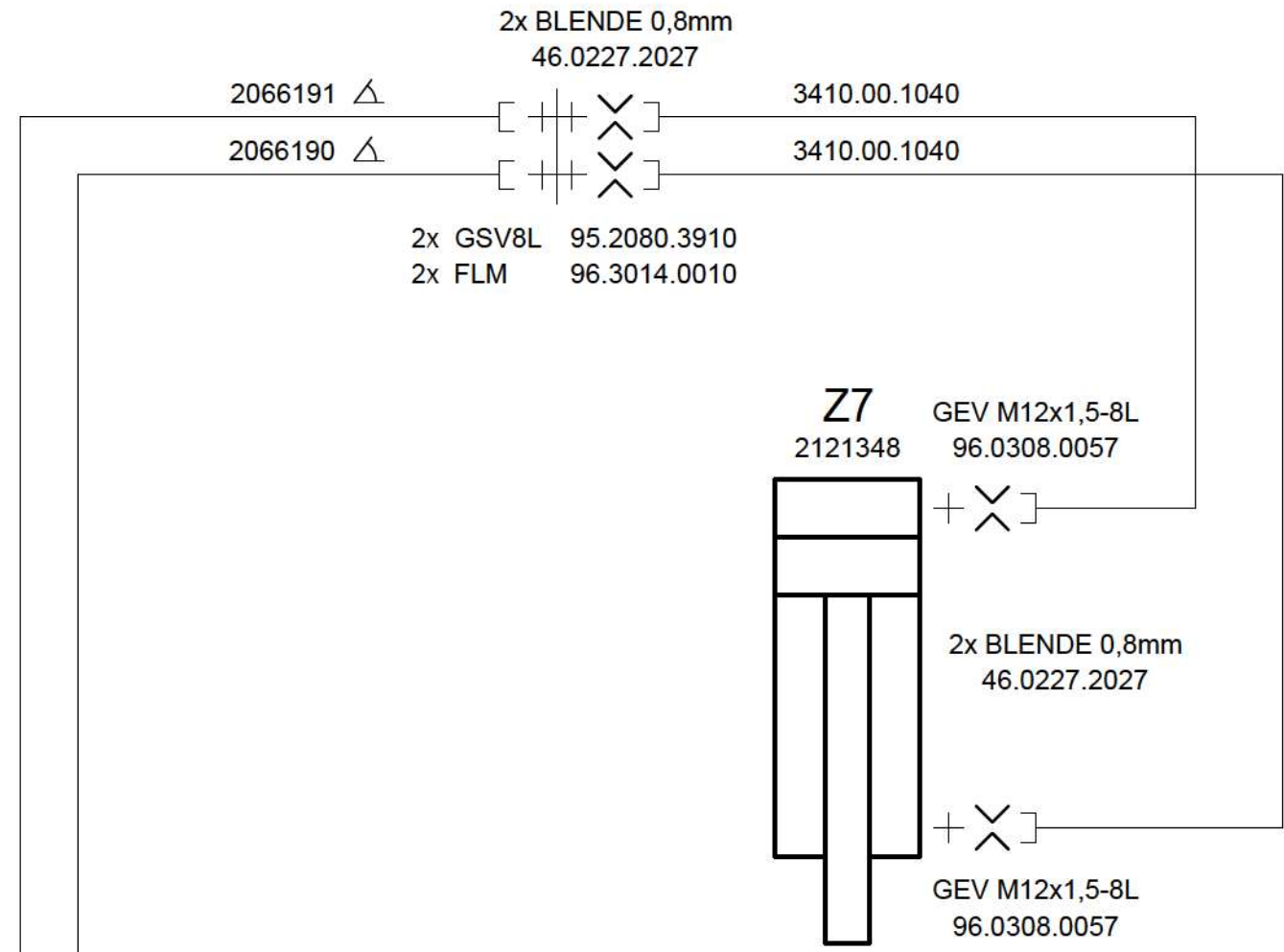
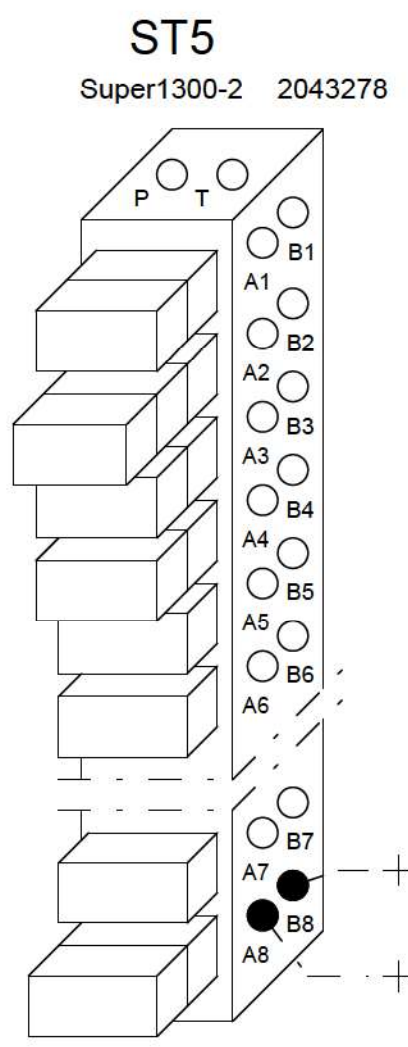

auf/ab
up/down

Schutzvermerk nach ISO 16016 beachten/Refer to protection notice ISO 16016

Modification	Date	Name	Date	Name	Machine Key Code:	Ident-No.:	Spot:	Plan
a					08.11	2173308 00		
b			07.10.09	Letz	0811 0409 - XXXX	Verteilerschnecke auger		Bl.: 26 sh.: 30
c			gepr.					Bl.: 30
d								Bl.:

VÖGELE Joseph Vögele AG

FR ←

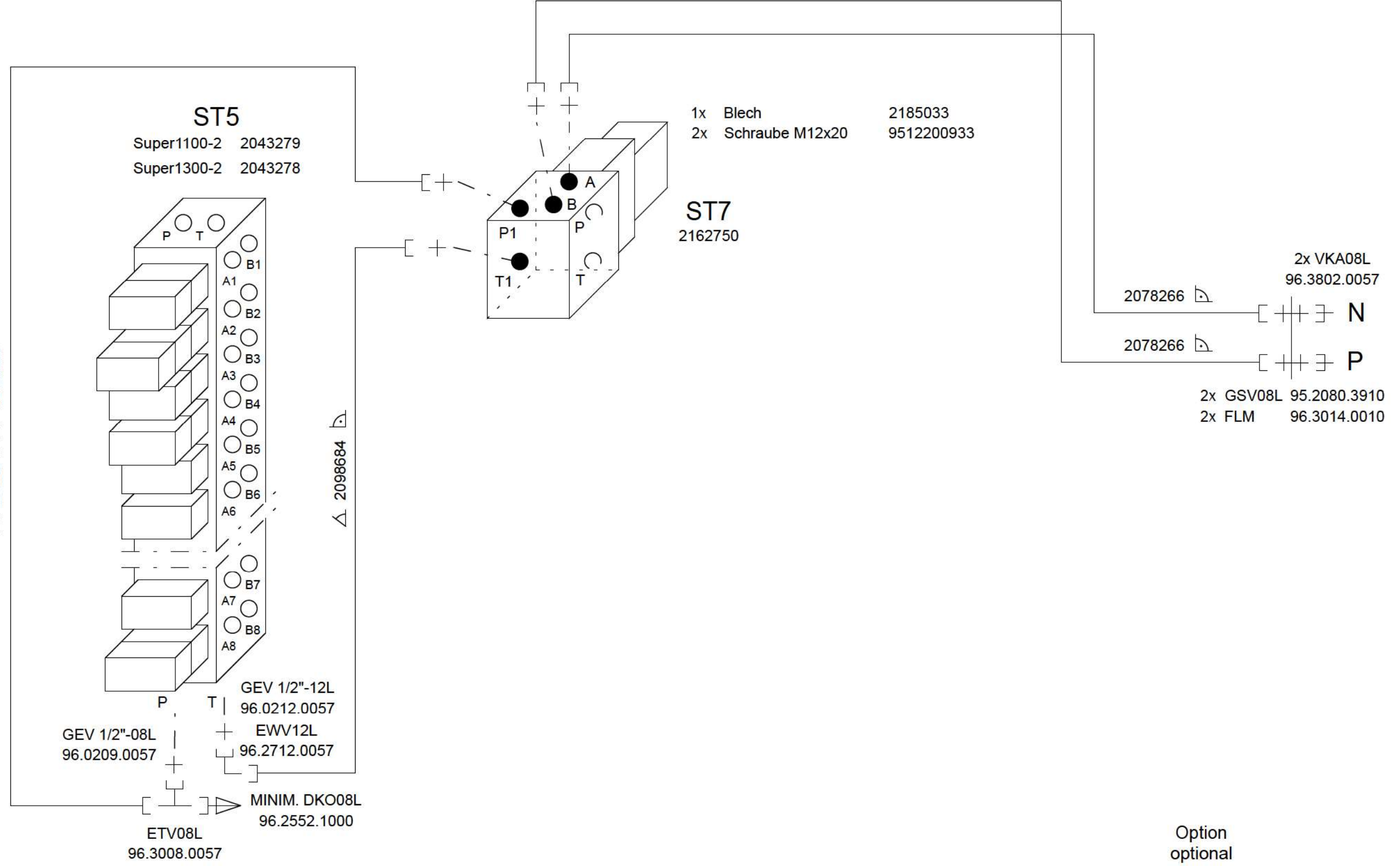

Schutzvermerk nach ISO 16016 beachten/Refer to protection notice ISO 16016

Modification	Date	Name	Date	Name	Machine Key Code:	Ident-No.:	Spot:	Plan
a					08.11	2173308 00		
b			07.10.09	Drwn.				
c				gepr.	0811 0409 - XXXX	Dachprofilverstellung crown adjusting device		Bl.: 27 sh.: 30
d								Bl.: sh.: Bl.:

VÖGELE Joseph Vögele AG

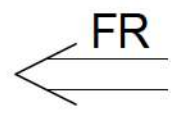

2x SCHRAUBE M12x25
95.1225.0933

F4
2010804

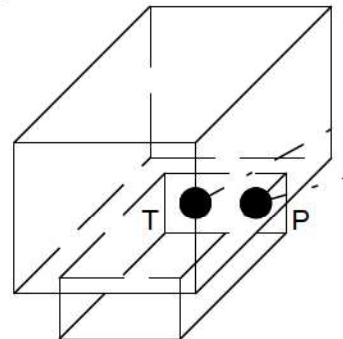

GEV M18x1,5-12L
96.0313.0057

△ 2080132

GEV M12x1,5-12L
96.0305.0057

2065928 △

Q1
2043270

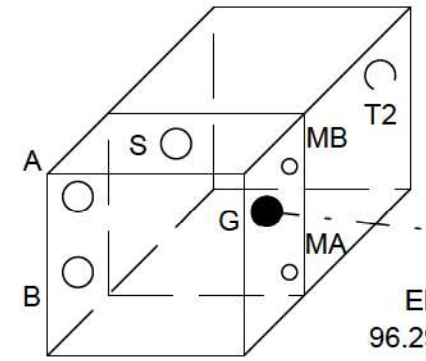

ELV12L
96.2912.0057

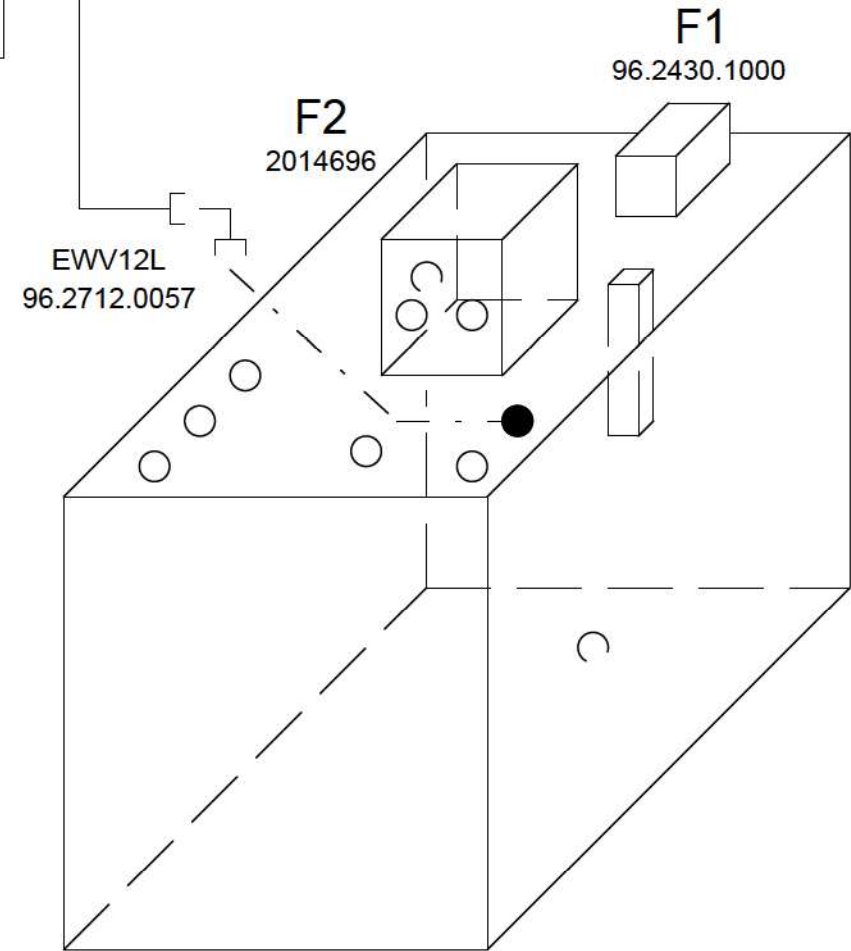

F1
96.2430.1000

F2
2014696

EWV12L
96.2712.0057

Schutzvermerk nach ISO 16016 beachten/Refer to protection notice ISO 16016

Modification	Date	Name	Date	Name	Machine Key Code:	Ident-No.:	Spot:	Plan
a					08.11	2173308 00		
b			07.10.09	Letz				
c					0811 0409 - XXXX	Filter		Bl.: 29
d						filter		sh.: 30 Bl.:



Joseph Vögele AG

FR
 ←
 2050976

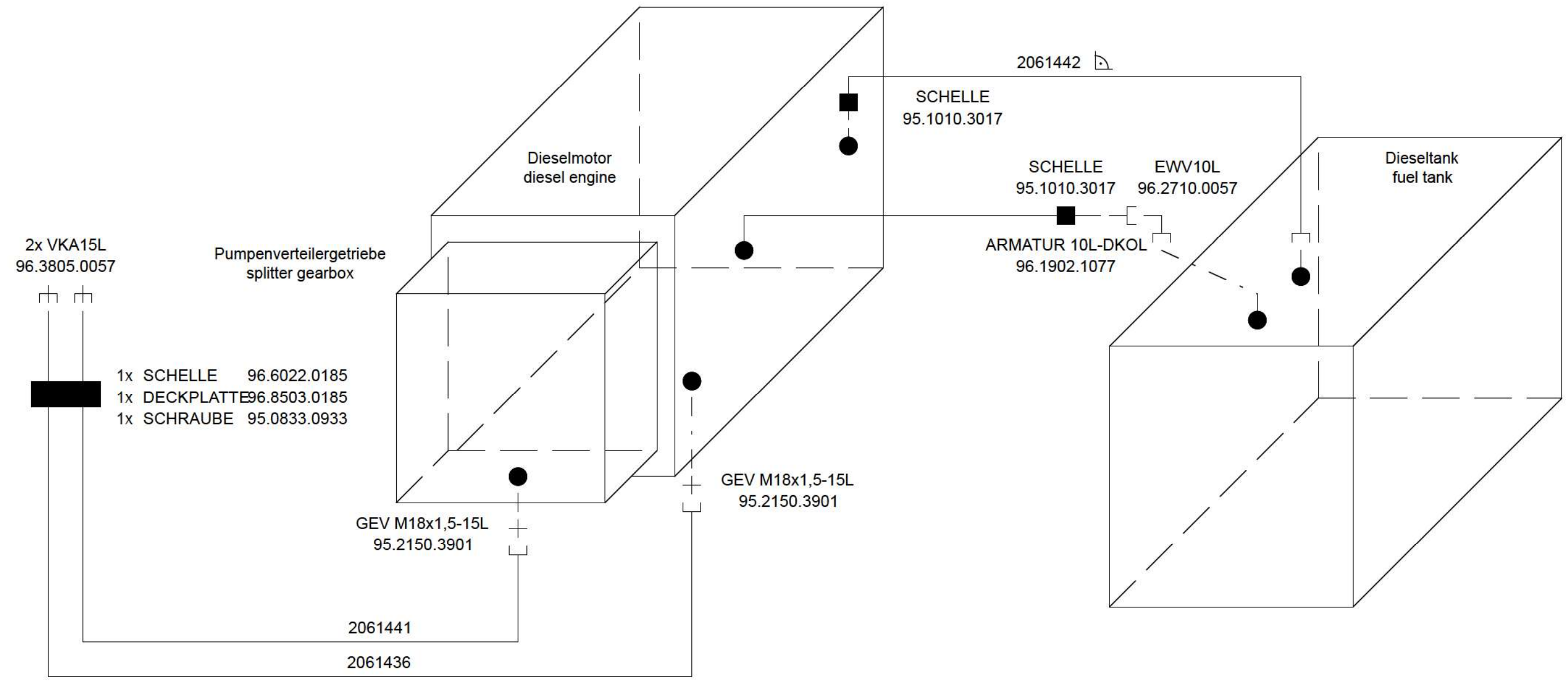

Schutzvermerk nach ISO 16016 beachten/Refer to protection notice ISO 16016

Modification	Date	Name	Date	Name	Machine Key Code:	Ident-No.:	Spot:	Plan
a					08.11	2173308 00		
b			07.10.09	Letz				
c					0811 0409 - XXXX	Designation:		Bl.: 30
d						Dieselmotor diesel engine		sh.: 30 Bl.:

VÖGELE Joseph Vögele AG