

■ Electronically Controlled Air Suspension (ECAS) for Trailers

Function and Fitting Instructions

■ 3rd Edition

This publication is not subject to any update service.
New versions are available in INFORM at
www.wabco-auto.com

■ © 2005 WABCO

WABCO

The right of amendment is reserved
Version 003/10.04en
815 010 025 3

Table of contents

Table of contents

1. Important Remarks and Comments	3	8.2	Electronic Control Unit (ECU) 446 055 ... 0	27
1.1	Advises for Security and Risks	3		
1.2	Range of Application	3	8.2.1	Installation
1.3	Explanation of Symbols	3	8.2.2	Pin Assignment (ECU variant 446 055 065 0)
2. Introduction	4	8.2.3	Power Supply and Diagnostic Assignment	31
2.1	System Benefits	5	8.2.4	Battery Mode
3. System Functions	6	8.3	ECAS Solenoid Valve	34
3.1	Reference Level Control	6	8.3.1	Spring-Returned Valve
3.1.1	Driving Level I	7	8.3.2	Pulse-Controlled Sliding Valves
3.1.2	Driving Levels II and III	7	8.3.3	Difference between 3/2-, 2/2- and 3/3-Way Valve
3.1.3	Unloading Level	8	8.3.4	Differentiating of the ECAS Solenoid Valves depending on their location
3.1.4	Memory Level	8	8.4	Remote Control Unit 446 056 116/117 0
3.1.5	Automatic Lowering	8	8.4.1	Remote Control Unit Function 446 056 117 0
3.2	Height Limitation	9	8.5	Remote Control Box
3.3	Lateral Stabilisation	9	8.6	Battery Box
3.4	Lifting Axle Control	9	8.7	Pneumatic Components and Installation Instruction
3.5	Offset Point Adjustment (Lifting Axle Offset)	9	9. Commissioning and Diagnostics	46
3.6	Traction Help	9	9.1	PC Diagnostics
3.7	Overload Protection	9	9.1.1	PIN
3.8	Tyre Deflection Compensation	10	9.1.2	Initializing the ECU
3.9	Stand-By Function	10	9.2	Setting Parameters
3.10	Further ECAS-Functions on Bus and Motor Vehicle	10	9.2.1	Option Parameters
3.10.1	Control of Load Sensing Valve	10	9.2.2	Value Parameters
3.10.2	Kneeling	10	9.2.3	Counts
3.10.3	Maximum in Traction Control at all time	10	9.2.4	Explanation of Parameters
4. Basic Operation	11	9.3	Calibration Process	65
4.1	Mode of Function of the ECAS Basis System	11	9.3.1	Height Sensor Calibration
5. Control Algorithm	12	9.3.1.1	Height Sensor Calibration with the PC	67
5.1	Control Algorithm for Levelling Control	12	9.3.2	Pressure Sensor Calibration
5.2	Control Algorithm for Lifting Axle Control (general)	14	10. Troubleshooting	69
5.2.1	Control Algorithm for Lifting Axle Control (one Lifting Axle)	15	10.1	Safety Concept
5.2.2	Control Traction Help	17	10.2	Troubleshooting
5.2.2.1	Trailing Axle Control (Manoeuvre Aid)	18	11. Replacement older Components	73
5.2.3	Control Algorithm for Lifting Axle Control (two separate Lifting Axles)	18	11.1	Fitting a new ECU
6. Tyre Deflection Compensation	21	11.2	Replacement of the Power Supply Module	75
7. System Configuration	22	11.3	Component Replacement	75
7.1	Control in the Trailer	23	12. Annex	79
7.1.1	1-Point Control	23		Trailer ECAS Parameter Setting
7.1.2	2-Point Control	23		Explanation of the Example Parameter Records
7.1.3	3-Point Control	23		Overview Circuit Diagrams
8. Components	24			Parameters Records + Circuit Diagrams
8.1	Sensors	24		Cable Overview
8.1.1	Height Sensor 441 050 011 0	24		Certificate of German Technical Inspection Agency
8.1.2	Pressure Sensor	26		182
				184

1. Important Remarks and Comments

1.1 Advises for Security and Risks

ECAS is a vehicle security system. Changes on the setting of the system are allowed only to persons with necessary technical knowledge.

When the ignition is switched on or while diagnostics starts unexpected movements of the vehicle or sudden raise/lower of the lifting axle can occur.

If you work on the air suspension system, advise other persons by affixing an information sign on the steering wheel of the vehicle.

It is not allowed to combine ECAS with other air suspension control systems, since the possibility of dangerous interactions cannot be excluded.

Following points have to be observed when welding at the trailer :

- The electronics have to disconnect from power supply (break off pin 31, 15 and 30). At least, the supply line between the towing vehicle and trailer is to be taken off.
- System components (ECU, sensors, actuators, lines etc.) are not being contacted with welding electrodes.

Never drive with the superstructure lowered onto the buffer, because vehicle and loading can be badly damaged.

1.2 Range of Application

 ECAS was designed only for suspension control in air sprung vehicles.
It is not permitted to place more than one ECAS system to a trailer.

 To avoid dangerous interaction, combination with other air suspension control systems are not admissible.

Important Basic Requirements for Operation with ECAS:

- Compressed air supply must be realized sufficiently.
- Power supply has to be ensured.
- ABS connection or EBS connection must be plug in.



To work on the ECAS system, take only information shown on circuit diagrams identified with a ten-digit WABCO number.

Circuit diagrams without a WABCO number may be incorrect. They are considered to be diagrams for which no release from WABCO exists.

WABCO does not assume any warranty for systems which are designed in another way than described here.

You need the approval of WABCO for the:

- Usage of components other than those shown in the circuit diagrams (cables, valves, sensors, remote control units),
- Inclusion of any appliances by other manufacturers in the system or
- Implementation of other functions than those described above.



The structure of the ECAS system is shown by many circuit diagrams in the annex.

1.3 Explanation of Symbols



Possible dangers,
Personal injury or material loss



Additional hints, info, tips



WABCO experimental value(s),
recommendation

- enumeration
- action step
- ↑ refer to (prior paragraph, prior chapter, prior illustration/table)
- ↓ refer to (prior paragraph, prior chapter, prior illustration/table)

2. Introduction

Air suspension systems have been used on motor vehicles since the 50s - especially on buses. They clearly improve ride comfort.

On lorries and trailers, air suspension systems are being increasingly used, particularly on vehicles designed to carry heavy loads. The main reasons for this are special design criteria for the chassis. As static loads can vary significantly on the motor vehicle's real axle, and on all axles of a trailer from the unladen vehicle to the fully laden vehicle. Steel suspension can cause problems when the vehicle is unladen or partially laden. The suspension behaviour deteriorates. In addition, ride comfort plays an important role, not only on buses.

The Benefits of Air Suspension Systems over Leaf Spring Suspension Systems

- The whole of spring travel is available for balancing dynamic axle load cycles. Static axle load cycles are compensated by means of pressure changes. This in turn achieving additional height for the design of the superstructure.
- The best possible suspension regardless of the road condition and the load carried improves ride comfort and protects the load. No rolling noise of the vehicle is transmitted.
- The wheels run evenly on the road surfaces; this improves braking performance and steerability and considerably extends the life of the vehicle's tyres.
- Accurate load-dependent control of the compressed-air braking system by using the bellows pressure as the actuating pressure for the load sensing valve.
- Constant vehicle height is irrespective of the static load.
- Controlled raising and lowering processes for loading ramp and container operation.
- Control of lifting axles.
- Individual control of the bellows pressure to compensate lateral forces (e.g. when negotiating bends).
- Protecting the road surface.

Disadvantages of Conventional Air Suspension Systems compared to Leaf Spring Suspension Systems

- More expensive system,
- More complicated axle systems due to the use of axle steering and axle stabilisers,
- A large number of parts due to numerous air components,

- Significant wear of control valves due to constant increase or decrease in pressure; shorter life due to continuously alternating stress
- control of cornering angles.

Designing the control system initially with pure mechanically operating air suspension valves, soon afterwards electromechanic control systems were developed. This served to enhance operating comfort and to facilitate raising/lowering processes.

ECAS is the most advanced development along these lines. The use of an ECU has achieved major improvements over the conventional system.

ECAS - Electronically Controlled Air Suspension

(Electronically controlled air suspension system)

ECAS is an electronically controlled air suspension system for vehicles with a large number of functions. It has been used on motor vehicle since about the early 80s.

In the mechanically controlled air suspension systems the device which measures the height also controls the air spring. While ECAS achieves control by means of an ECU. It actuates the air spring via solenoid valves, using information received from sensors.

In addition to controlling the vehicle's level, the ECU, together with the remote control unit, also controls functions which, if implemented with conventional air suspension systems, require a large number of components.

With ECAS, additional functions can be implemented which cannot be achieved by conventional means.

ECAS essentially operates only when the ignition is on. However, if a storage battery is used, stand-by operation can be activated.

For trailers, power is supplied from the ABS or the EBS system. In addition, ABS provides the so-called C3 signal, i.e. information on the vehicle's current speed. On trailers where ECAS works with EBS, the ECAS system receives information about the vehicle's speed and axle load from the EBS-ECU via a data circuit which is also known as the K-line.

A storage battery is provided for additional power supply in the trailer. Due to this the trailer separated from the towing vehicle can be adjusted in the height.

2.1 System Benefits

ECAS offers the following benefits:

Advantages for the Trailer Manufacturer

- Easy installation due to pre-wired components
- Reduced installation time due to a smaller number of components, screw-in units, less piping
- Quicker system start-up via PC end-of-line.

Benefits to the Carrier

- Highly service-friendly,
- Low error liability
- Short laidup times,
- Various safety functions for the vehicle (e.g. compensating for tyre deflection, time delay for the unloading level, overload protection),
- Automatic return to driving level,
- Highly variable operation due to different driving levels,

- Very rapid raising and lowering times,
- High level of comfort and safety due to traction help for semi-trailer trains and automatic lifting axle function,
- Can easily be retrofitted,
- Low air consumption due to rugged control concept,
- Reduction of the amount of manoeuvring and loading times and thus shorter dispatching times through storage of loading levels which are easy to address via the remote control unit plus the option of raising or lowering only one side of the superstructure.

Advantages for the Owner of the Cargo

- Protection of the load,
- Adaption of the vehicle to the carrying task due to the universal nature of the system,
- Reduction of the amount of manoeuvring and loading times and thus shorter dispatching times through storage of loading levels which are easy to call up via the remote control unit.

3. System Functions

Before the system functions for achieving the above system advantage are explained, please note the following basic definitions to facilitate comprehension.

Trailers can have different Types of Axles

The Main Axle (also known as the Leading Axle)

The axle is always on the the ground and cannot be steered. Every trailer has a leading axle. On drawbar trailers the rear axle is the leading axle.

Steering Axle

The steering axle is an axle on a trailer which is steerable. On drawbar trailers, the front axle is the steering axle. Semi-trailers can have a the trailing axles as a steering axle.

Lifting Axle

The lifting axle is usually combined with the leading axle to form an axle assembly. When the vehicle exceeds a defined axle load on its leading axle, the lifting axle is lowered and can be raised again when the axle load falls below a defined level.

Air Suspension bellows in Air Suspension Systems

Supporting Bellows

Supporting bellows are the commonly known air suspension bellows on the axles. They provide the vehicle's suspension. The supporting bellows on the axles which are in contact with the ground are always filled with a bellows pressure which is proportional to the applicable wheel load while the vehicle is in operation. The supporting bellows of raised axles are depressurised. Supporting bellows are found on all the types of axles described above.

Lifting Bellows

Lifting bellows are firmly connected to a lever system of the lifting axle. They raise or lower the lifting axle when the pressure exceeds or falls below a defined limit pressure in the supporting bellows of the axle assembly's driven axle.

ECAS is a control system consisting of at least one control loop. A reference value is specified in a control loop. A sensor is adapted to the system due to a calibration process when the system is taken into operation. This sensor measures the actual value of the system and sends it to an electronic control unit (ECU).

The ECU compares the actual value to the reference value. During this process it is possible to determine control deviations .

That means, that the actual value lies outside a defined reference range.

In the event of a deviation the ECU initiates the correction of the reference value via an actuator.

Reference Values are:

- Certain distances (levels) of the vehicle's superstructure above the vehicles's axle,
- Axle load vehicle conditions (e.g. traction help, limit pressure for lifting axle control).

Two Ways to Submission the Reference Value to the ECU:

- Fixing preference values by the vehicle manufacturer during the systems startup by setting parameters and by calibration.
- The user setting the values via the remote control unit.

Please note that not all the functions described in this document have to be available, depending on the type of system realized. The type of system (amount of lifting axles, with/without front axle air suspension) determines whether or not the functions can be implemented.

ECAS can be fitted to every vehicle type without problems. Due to the modular construction various system usages according to customer requirements are possible.

3.1 Controlling the Reference Level

The reference level is the value for the distance between the vehicle's superstructure and the axle. It is defined by calibration, by setting parameters or by defining a value using a remote control unit. Correcting a reference level is the basic functions of ECAS.

The actuator is a solenoid valve by increasing and decreasing of the pressure in the supporting bellows bringing the actual level into line with the reference level. This occurs if there are:

- Deviations over a certain tolerance range,
- Alteration of the reference value.

Unlike conventional air suspension systems, ECAS controls not only the driving level but also any other predefined level. Therefore a level which is set for loading or unloading processes is assumed to be the reference level.

Differentiation of Static/Dynamic Changes in the Wheel Load

By using the speed signal ECAS differentiates between static and dynamic changes in the wheel load, unlike conventional air suspension systems. Due to this differentiation the system can react optimally to changes in the wheel load.

Static Wheel Load Changes

The static wheel load changes occur if the vehicle's loading state changes when it is stationary or moving slowly. This requires the reference value in the corresponding air suspension bellows to be checked at short intervals and adjusted if necessary by increasing or reducing the air pressure. ECAS does this performing checks every second. This inspection cycle can be set in the parameters.

Dynamic Wheel Load Changes

The dynamic wheel load changes are mainly caused by uneven road surfaces and is more likely to occur by high speed. Dynamic wheel load changes are usually balanced by the compliance behaviour of the supporting bellows. In this case, bellow pressurizing or venting would not be desirable because only the shut-off bellow has an almost constant compliance character. For this reason, the regulation is checked in larger intervals when the vehicle is moving at higher speed - usually every 60 seconds. The comparison of actual value to the reference value is made continuously.

It is possible to avoid unwanted corrections of dynamic wheel load changes during braking, so no air is pumped into or vented from the bellows, when the ECU receives the brake light signal.

Driving Level

The driving level (also known as normal level) adjusts itself when the vehicle moves on a higher speed. A maximum of 3 driving levels can be set for ECAS.

3.1.1. Driving Level I

Driving level I refers to the reference level defined by the vehicle manufacturer for driving under optimal conditions. This driving level is the basis for the dimensions of the vehicle's overall height and the vehicle's theoretical centre of gravity. It has a special meaning compared to other driving levels.

Driving level I is described as the basic design parameter for the vehicle.

 Please note to take the legally permitted maximum into account considered to the total height.

The vehicle's theoretical centre of gravity is a reference value for calculation the vehicle's braking.

- Inform the system over the driving level I only by calibration process.
- Control the driving level I over the vehicle's speed and/or over the remote control unit during the journey.
- Set speed value for the point of actuation for controlling the parameters.

3.1.2 Driving Levels II and III

Both driving levels differ to driving level I. This may be necessary:

- For semi-trailers with varying truck heights to keep the trailer in horizontal level while driving,
- For trailers to lowering the superstructure in order to reduce fuel consumption,
- For improving lateral stability at higher speed.

By lowering the superstructure depending on the vehicle's speed, is based on the assumption that higher speeds are achieved on sound road surfaces which do not require the whole of the bellows' spring stroke to be utilised.

- Store the values of driving level I and II in the system by setting the parameters and as defined variance from driving level I.

This driving level can optionally be set by:

- Switch,
- Remote control unit,
- Driving speed (only driving level II).

The chosen driving level remains until another driving level is selected.

- To start up with the actual driving level touch shortly the button driving level.
- Set the values for the type and the switching points for actuation during the parameterization,
- Define driving level III as the highest driving level.

3.1.3 Unloading Level

The unloading level is used for loading or unloading a vehicle, while it is stationary or moving at a slow speed. It permits the vehicle's superstructure to be brought to a level suitable for the loading or unloading process. The unloading level can be stipulated separately for a drawbar trailer's front and rear axles. This can be useful, for instance, for completely emptying of a tank trailer.

- The values of these unloading level are defined as the variance from driving level I and store in the system as part of the procedure for setting the parameters.

! If an unloading level function is desired, no driving level III can be set.

- The unloading level is addressed via an on the ECU connected switching contact, the so-called unloading level switch.

This switching contact can either be actuated manually or via an automatic connection to the unloading fixture (e.g. a tank valve) to readdress the current driving level.

If the unloading level is active, the vehicle will return to its driving level as soon as a limit speed is exceeded. When the speed drops below that speed, the unloading level is set once again.

- The unloading level can be activated from any preset level.

3.1.4 Memory Level

Two different memory levels can be used per system. The memory level applies to the whole of the vehicle. The use of the memory function requires a remote control unit.

The Memory Level can be addressed:

- For loading or unloading a vehicle while it is stationary or
- moving at a slow speed.

This level is used in order to set a level for the superstructure which is useful for loading or unloading the vehicle. Unlike the unloading level, which is firmly stored in the ECU, the memory level can be defined and changed any time. Once defined, the system will store any memory level until it is changed by the user, i.e. even when the ignition has been switched off.

3.1.5 Automatic Lowering

If required, raised lifting axles can be lowered automatically by the driver.

This may be necessary:

- when the vehicle is been serviced,
- for improving stability on poor road surfaces.

If the vehicle has two separate controlled lifting axles, an option parameter can be set to determine whether:

- Both lifting axles is to be lowered.
- Only the second lifting axles is to be lowered.

Options for Lowering Raised Lifting Axles:

1. Lowering Command via Remote Control Unit

- Push the Lower button on the remote control unit of the preselected lifting axle.

The lifting axles lowers and will stay down until the system is reset by switching the ignition off and then on again.

- Push the Raise button on the remote control unit on the preselected lifting axle.

The lifting axles will raise again.

2. Lowering Command via Traction Help Key

- Hold button Traction Help down for longer then 5 seconds.

The lifting axles will be lowered and stay down until reset. The automatic lowering function remains activated, until the ignition is turned off or the button is pushed again longer then 5 seconds.

All lifting axles are always lowered independent of parameter 4 Bit 4.

3. By using a Separate Switch and a Line to the Switching Input Port for Automatic Lowering on the ECU.

- Make sure the ground is connected to the contact.

The lifting axles are lowered. Automatic lowering remains active even after the ignition is switched off or on. The function remains active as long as the switch is active.

- Open the contact.

The lifting axles will raise again.

These lowering processes are all permissible up to a limiting speed defined by parameter. If fully automatic lifting axle operating is in place, raising will, depending on the parameter setting, occur while the vehicle is stationary or when it exceeds a defined speed.

A vehicle with two separate lifting axles whose parameters have been set for lowering both axles and for raising them only when the vehicle begins to move, has its lifting axles raised as follows:

- Deactivate automatic lowering switch.

Axle 1 will be raised immediately.

Axle 2 will be raised once the vehicle has been stopped and its speed subsequently rises above that required for raising the lifting axles.

3.2 Height Limitation

The ECU automatically aborts any change in the level if the defined value for the upper and lower height limits have been reached. These values can be freely selected. This is in order to prevent excessive strain on the rubber buffers and height limit stops (e.g. bellows, limiting cables).

3.3 Lateral Stabilization

Vehicles expected to carry loads which are unevenly distributed across its axles (e.g. loading on one side of the vehicle only), can have variable spring rates provided on the supporting bellows of one axle by separating the actuation for the individual bellows.

- These vehicles should be fitted with 2-point control (↓ 7. system configuration).

This is not required for vehicles carrying evenly distributed loads (e.g. road tanks).

3.4 Lifting Axle Control

When the vehicle is stationary, its lifting axle will automatically be lowered or weight shifted to the trailing axle, when the permissible axle load of the leading axle is exceeded. The corresponding signal reaches the ECU from the pressure sensor (↓ 8.1.2 Pressure sensor) or the pressure switch at the suspension bellows of the leading axle. The lifting axle cannot automatically be lowered when the vehicle is in motion, even when pressure spikes occur.

The speed up to which the lifting axle can be lowered can be set by parameters.

For safety reasons, the lifting axle is lowered when the vehicle is parked and the ignition is switched off. Optionally, the lifting axle may stay up.

Pressure Sensor System

In systems with pressure sensors, the lifting axle can be lowered and also raised automatically after the vehicle has been unloaded. The term used for this is 'fully automatic lifting axle'.

Pressure Switches/-Buttons system

The lifting axle is lowered automatically. The raising is achieved manually by means of the ECAS remote control unit or a separate button/switch.

A raised lifting axle can be lowered by way of an automatic lowering function.

3.5 Offset Point Adjustment (Lifting Axle Offset)

When the lifting axle is raised, the driving level can be increased automatically. Due to this a better clearance of the lifting axle's wheels is achieved. This applies to the whole of the vehicle.

3.6 Traction Help

On semi-trailers, traction help can be implemented if the fully automatic lifting axle facility has been selected and the load is heavy enough. By releasing the pressure on the lifting axle's supporting bellows or raising the lifting axle, the load on the towing vehicle's semi-trailer coupling and on the leading axle is increased. This means that the load on the driving axle of the towing vehicle is increased, the purpose being to improve its traction force.

- Activate the traction help function by using the remote control unit or by a rocking Switch.

At present, the applicable national legal provisions met by setting the corresponding parameters accordingly (with/without time speed, load limits, with/without forced interval). Upon EC Guideline 97/27/EC comes into force, this results in changes which have been taken into account when setting the parameters.

3.7 Overload Protection

By stipulating a maximum permissible pressure for the supporting ballows, overload protection can be activated.

This protection leads to a lowering of the vehicle's superstructure down to the rubber buffers, if the supporting bellow pressure was exceeded by overloading.

- You need to unload the vehicle until the vehicle's superstructure can be lifted by the remote control unit.



Do not drive with the lowered superstructure, vehicle and loading can be badly damaged.

3.8 Tyre Deflection Compensating

For vehicles with a particularly great overall height, not only small wheels are used to maintain the vehicle height, but a very short ride clearance is selected for the empty vehicle.

However, as the vehicle is being loaded, the required ride clearance increases. It is possible to add the tyre deflection caused by increasing the load to the possible ride clearance, at the same time keeping the overall height of the vehicle constant.

 The vehicle height required by law has to be maintained.

3.9 Stand-By Function

If a separate trailer battery and sufficient air supply are available, stand-by operation can be achieved for a maximum of 63.5 hours. For this purpose, the trailer does not have to be attached to any towing vehicle, and it will at that time address the last level before the ignition was switched off as the reference level. To reduce the control cycles to a minimum it is possible to increase the tolerance range.

3.10 Further ECAS Functions on Bus and Motor Vehicle

Additional functions, although not of importance for trailers, can be implemented with the assistance of ECAS on buses and motor vehicles.

3.10.1 Control of Load Sensing Valve

Towing vehicles and trailers with air suspension systems and a conventional braking system have a load sensing valve fitted which is controlled by the bellows pressure.

In the event of a rapid loss in pressure in the bellows (e.g. bellows leaking badly or severely damaged), the load sensing valve would assume an empty vehicle in spite of it being fully loaded. As a consequence, underbraking would ensue, and with it excessive stopping distances. ECAS contains a facility for recognizing this so that when it occurs, the supply pressure of the air suspension system would be passed to load sensing control port 41/42. This results in a pass through of the load sensing valve. ECAS also provides this facilities for trailers. Therefore a 3/2 solenoid valve has to be installed in control line between air suspension bellows and the load sensing control port 41/42.

This option is mainly being used in towing vehicles.

3.10.2 Kneeling

Kneeling is a special function for buses. With the bus stationary at the bus stop, the whole of its nearside is lowered facilitate getting on and off the bus. It "kneels" in front of the passenger, so to speak. A "kerb sensor" i.e. contact strip below the entrance, prevents it from touching down on any obstacle.

3.10.3 Maximum in Traction Control at all time

ECAS offers the following possibilities on motor vehicles with lifting axle:

The lifting axle is lowered in load conditions. The distribution of the axle load across the rear axle assembly can be controlled in such a way that the driving axle (within the scope of legal provisions and the stipulations by the axle manufacturers) carries the greatest possible load, with the lifting axle supporting the residual load. Thus the driving forces which can be transferred to the driven axle are always at their maximum, thereby permitting good traction.

4. Basic Operation

In this chapter the operation of ECAS will now be looked at in a little more detail.

The basic purpose of ECAS is to balance any control deviations. Control deviations are caused either by disturbances (such as a change in the load) or by changes in the reference values (e.g. by way of the remote control unit). These control deviation cause the distance between the vehicle's axle and its superstructure to change. ECAS balances these control deviations by means of levelling control.

4.1 Functioning of the ECAS Basis System

(↓ Fig. 1)

1. A height sensor (1) which is mounted on the vehicle's superstructure and connected to its axle via a lever system. The height sensor picks up the distance between the axle and the superstructure, or bodywork.

The intervals depend on the vehicles type of operating (driving or loading operation).

2. This measured value is used as the actual value in the control loop and is sent to the electronic control unit (2).
3. The ECU compares this actual value to the reference value stored.
4. In the event of a control deviation the ECAS solenoid valve (3) receives an actuating signal.
5. Depending on the type of actuating signal received, the ECAS solenoid valve now increases or decreases the air pressure in the supporting bellows (4). The change in pressure in the supporting bellows changes the distance between the axle and the superstructure.
6. The new distance is again detected by the height sensor, and the cycle begins again.

The remote control unit (5) is no longer part of the ECAS basic system. It is still mentioned because it allows the user actively to change the reference level.

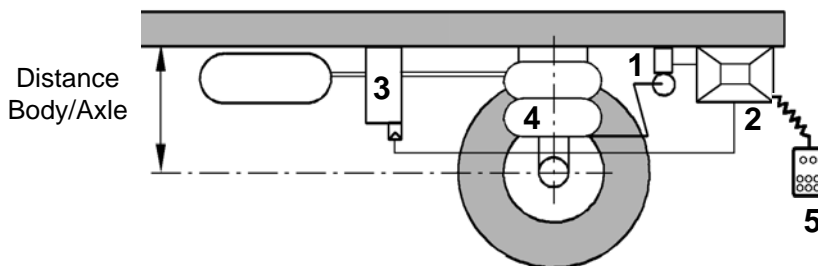

Fig. 1 Basic Operation of the ECAS System

Basic System:

- 1 Height Sensor
- 2 Electronic (ECU)
- 3 ECAS Solenoid Valve
- 4 Supporting Bellows
- 5 Remote Control Unit (optional)

5. Control Algorithm

5.1 Control Algorithm for Levelling Control

In levelling control, the distance between a vehicle's superstructure and axle is controlled. The levelling control is the basic function of ECAS.

It may be necessary to adjust that distance due to the influence disturbances, or because the reference value has to be changed.

In order effectively to describe how ECAS controls the levelling process, the basic physics of the air suspension system are described below.

General Comments on the Physics of ECAS

The basic problem in any control system when a control deviation occurs is to determine the best possible response time. This is the time from when the reference value starts to change up until the time when the actual value is no longer outside the tolerance range for the reference value (↓ Fig. 2). Until this is achieved, the control process continues and thus consumes air.

Long control times are the result of slow control adjustments of the actual value to the new reference value. Although this does achieve an excellent control performance, it also takes some time.

If control times are shorter, the time until the new reference value is achieved is reduced although this means that the system's tendency to oscillate increases.

The large nominal width of the ECAS solenoid valves, which is beneficial for adjusting small differences in reference values, is detrimental if the differences in reference values are great. In the latter results in the tendency in excessive oscillation increases.

Oscillation Damping and Damping Force

During the control process, the role of the oscillation damper has to be taken into account. Conventional oscillation dampers can be designed for one operating point only. The damping force for the vehicle is designed for the upper loading range. This means that for vehicles which are only partially laden or empty the part of the damping force which has to be overcome together with a change in the reference value is comparatively high. The could be compensated by variable damping control. This is available from WABCO under the name of ESAC. However, ESAC will not be taken into account in this document.

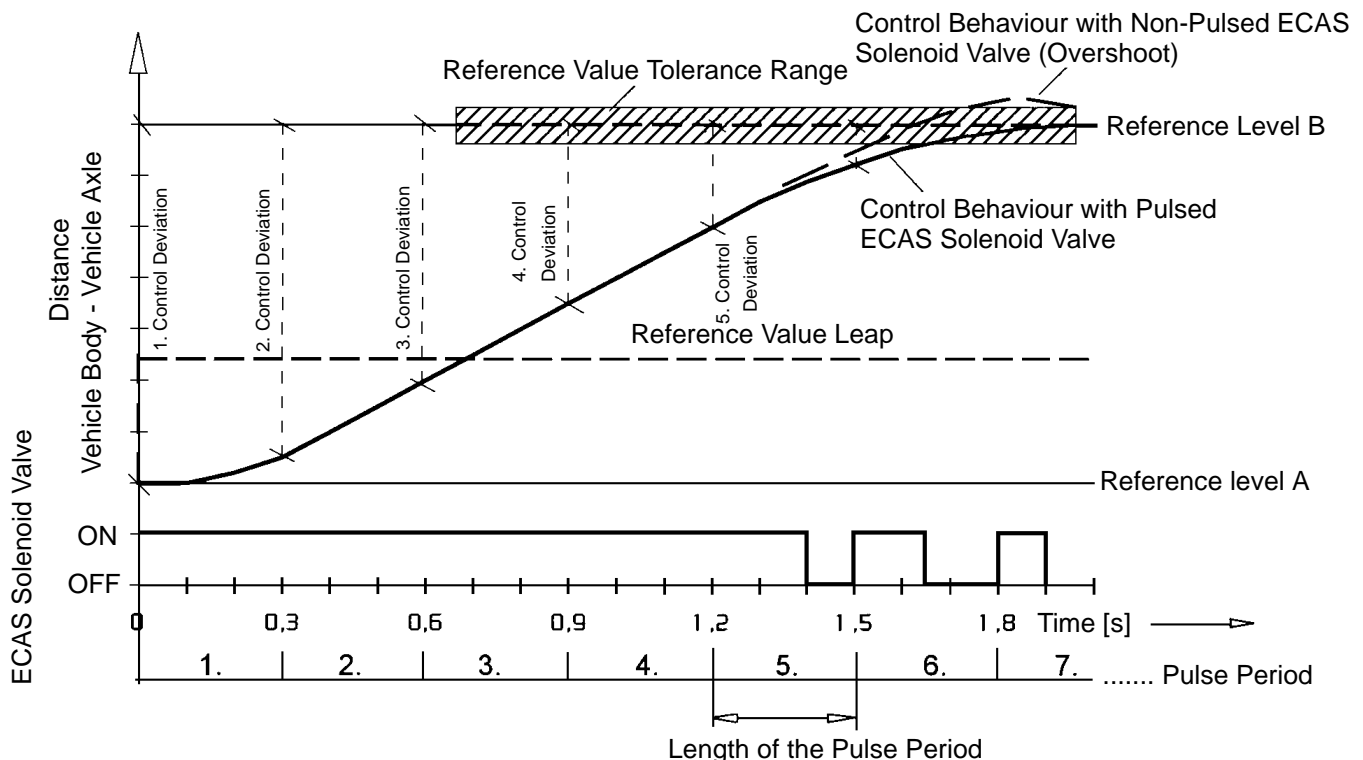

Fig. 2 Example for a Control Process for a Change in the Reference Value

The further the load is removed from the damper operating point, the greater the effect of the excess damping force will be.

This issue becomes clear when looking at the way the oscillation damper works. Inside the damper, oil needs to pass from one chamber via a small throttling port into another chamber. The resistance this causes is known as the damping force. A rapid change in the distance between the vehicle's superstructure and the axle also causes this damping force to rise rapidly.

Thus it is mainly the change in that distance which is responsible for building up the damping force.

As the distance between the superstructure and the axle changes, the damping force is simultaneously reduced by the damper oil flowing through the throttle. The time for this reduction is defined by the design of the damper (e.g. throttle diameter, viscosity of oil).

Now the damping force is a force counteracting the motion of the superstructure, and it prevents oscillation of the superstructure and the wheel losing contact with the road. However, it thus also counteracts the change in the level.

This damping force which varies over time represents a problem for the control process.

Control Process for Changes in the Reference Value

When the forces of ECAS are balanced, the wheel load acts on the supporting bellows of the axle. Any axle steering transmission must be taken into account.

The pressure in the supporting bellows multiplied by the effective cross-sectional area of the bellows (It cannot be computed directly from the diameter of the supporting bellows!) counteracts the wheel load. The pressure in the supporting bellows depends only on the wheel load, not the level.

As the level is changed as a result of the change in the reference value (e.g. by using the remote control unit), the pressure in the bellows is increased or decreased until the actual value for the distance between the superstructure and the axle corresponds to the new reference value. This is a dynamic process. The greater the desired change in the reference value, the greater the acceleration which can be achieved by the control process. The system shows a tendency to oscillate. Overshooting may occur.

This tendency to overshoot particularly occurs on empty vehicles. On the one hand the steep static pressure gradient between the supply and bellows pressure sides within the ECAS solenoid valve causes high flow rates as the bellows are being filled.

On the other hand the damping force to be overcome is greatest. Thus the hazard of the control loop oscillating is great. The result is an unnecessarily large number of control cycles within the ECAS solenoid valve which in turn reduces its useful life.

If the tolerance range for the reference value is defined widely enough, undesired oscillations can be prevented. However, this has a negative impact on the repetitive accuracy of the control process at similar reference values.

If, however, a specific dimension should be adhered to, the control process must be changed in such a way that the influx of air is reduced even before the reference level is reached. This would reduce the speed at which the superstructure is raised, and the excessive tendency to oscillate is prevented.

As the solenoid valve can only switch the air stream off or on but not reduce it, the solenoid current of the ECAS solenoid valve is pulsed. This pulsing action briefly interrupts the air stream. Thereby achieving a throttling effect which prevents excessive oscillation, i.e. overshooting.

Length of Pulsing Period and Pulse Length

For the pulsing process of the curve, the terms of 'length of the pulsing period' and 'pulse length' need to be defined:

Length of the pulse period

The length of the pulsing period is a fixed value which is stored in the ECU as part of the procedure for setting the parameters. The beginning of the pulsing period is assumed to be the actuating pulse for the valve solenoid. The length of the pulsing period itself is then the period of time before the valve solenoid receives the next actuating pulse. (↑ Fig. 2).

Pulse Length

The pulse length describes the length of time for which the valve solenoid receives the actuating pulse. This value is variable and is recomputed for each pulsing period. The computation of the pulse length by the ECU is done as a ratio of the existing control deviation, i.e. the difference between the reference level and the actual level.

This type of control is called 'proportional differential control' (or 'PD control' for short). The control process is achieved as a ratio of the control deviation and the speed at which the control deviation changes.

Major control deviations cause great pulse lengths. If the computed pulse length is greater than the stored length of the pulsing period, the valve solenoid is energized continuously. Thus the change in the control deviation is at its greatest.

As the large flow diameter causes the subsequent control process to be rapid as the vehicle's superstructure is being raised, it is slowed down just before the new reference value is reached; for this purpose, the speed at which the control deviation is changing is analysed and included in the control process. Control deviations changing at high speeds cause the pulse length to be reduced.

Equation for Calculating the Pulse Length by "Raising the Superstructure while Stationary"

Pulse length = (| control deviation x K_P | - | speed at which control deviation is changing x K_D |) x program cyclus time (≥ 25 ms)

K_P (Proportional coefficient) and K_D (Differential coefficient) are important for describing the control cycle and are stored in the ECU as part of the procedure for setting the parameters.

- In case of "lowering of the superstructure at standstill" and always by "regelation when driving" set the speed at which control deviation is changing to 0.

The equation shows:

- For K_P great control deviations or high values result in prolonged pulse lengths at equal control deviations.
- Whilst prolonged times for changes in the control deviation or high values at K_D at equal control deviations shorten the pulse length.

The pulse length is recomputed for each length of the pulsing period. A pulse length which exceeds the length of the pulsing period causes the solenoid to be energized continuously ('continuous pulse'). The shortest pulse length provided is 75 milliseconds (0.075 seconds).



Shorter pulse times would jeopardize the switching process of the solenoid valve at temperatures below - 40°C.

Determining the Parameters for the Proportional and Differential Coefficients

These factors have to be determined by way of trials on the vehicle. Like the other parameters, they lie within the scope of responsibility of the vehicle manufacturer. After the K_P -values have been finally determined for front and rear axle and stored in the ECU, the vehicle is taken to a level which is below the tolerance band for reference value.

If the driving level is reached without any excessive oscillation and without repeated pulsing of the solenoid valve, the setting for the reference level tolerance and

the proportional coefficient are acceptable.

The control process is now checked against a major change in the reference value. Now the differential coefficients K_D can be set. The object of establishing K_D is to suppress any tendency to oscillate excessively. Pulsing of the ECAS solenoid valve begins sooner as the K_D value increases. Thus the raising process of the superstructure is slowed down.

If it turns out that the K_P - and K_D values established according to these recommendations do not provide any satisfactory results for the control process. The flow diameter in the pneumatic portion may be reduced. Usually it is sufficient to fit a throttle in the air line between the solenoid valve and the supporting bellows unit of the axle concerned.

(↓ 9.4.1 Explanation of Parameters)

Summary

Thus it is concluded that the user can adjust the control process for the distance between the vehicle's superstructure and the axle by way of the following settings:

- Length of pulse period T ,
- Reference value tolerance Δs ,
- Proportional coefficient K_P ,
- Differential coefficient K_D ,

! To see which from values are to recommend and how they are to determine is described in paragraph 9.4 "Setting Parameters".

5.2 Control Algorithm for Lifting Axle Control (General)

Vehicles with a lifting axle can be equipped with a lifting axle control facility. This is an optional extra and is not necessarily included in every system.

Lifting axle control is used to control the position of the lifting axle(s). For this purpose, ECAS decides whether the lifting axle(s) has (have) to be down or raised. It is disturbance factors - usually changes in the load - which make it necessary to control the lifting axle(s).

With ECAS, a maximum of two lifting axles can be separately controlled. Experience has shown that vehicles with one lifting axle are more common. For this reason, the control of one lifting axle will be explained in order to illustrate the basic principle. Two separately actuated lifting axles are treated as one axle for this purpose. Having to separately control two lifting axle is the exception rather than the rule. This control principle is based on one lifting axle and is explained below.

General Comments on Lifting Axle Control

The subject of "lifting axle control" also includes subjects like "traction help" and "overload protection". These will also be covered in this context.

Controlling the position of the lifting axle is based on the pressure in the supporting bellows on the leading axle, this is picked up by one pressure sensor on the supporting bellows. The pressure reading is compared by the ECU to different reference values. These reference values can be defined as part of the commissioning process for the ECU. These reference values determine the following limits:

- Lowering or raising pressure for the lifting axle,
- Maximum permissible traction help pressure,
- Maximum permissible load pressure.

Thus every pressure value has a certain condition of the axle assembly allocated to it.

5.2.1 Control Algorithm for Lifting Axle Control (one Lifting Axle)

The thick line in the diagram (Fig. 3) shows the curve for the supporting bellows pressure on the trailer's leading axle as a ratio of the trailer's load. As the trailer is being loaded or unloaded, this line passes through different important points. Some of the pressures in the supporting bellows on the leading axle have to be stored in the ECAS system as part of the procedure for setting the parameters. Other pressures are the result of reactions of the lifting axle and can thus not be influenced - such pres-

ures have been marked with an asterisk (*).

! Proper lifting axle control requires a sufficient supply of compressed air and power.

For the purposes of the comments below, please imagine a tanker semi-trailer or trailer would be continuously filled with, or drained of, a liquid (↓ Fig. 3).

1. The filling process begins in Point ①. The trailer has an unladen weight m_{Empty} . This unladen weight is the combination of:
 - Mass of the trailer's superstructure and
 - the lifting axle mass proportion m_{LA} .
 The corresponding supporting bellows pressure p_{Empty} is shown on the reference plate for the load sensing valve.
2. The filling process which now begins increases the weight on the trailer until Point ② is reached. At this point, the lifting axle is lowered. Let us call the corresponding supporting bellows pressure $p_{LA Lower}$ this being the lowering pressure for the first lifting axle. The supporting bellows pressure has to be stored in the ECU when the parameters are set. The standard value for this pressure is the permissible nominal value $p_{100\%}$ of the pressure in the supporting bellows when the vehicle is fully laden. This value is also shown on the reference plate for the load sensing valve. The lowering pressure for the lifting axle can also be selected at a point which is lower than the permissible nominal pressure if the customer considers this necessary.

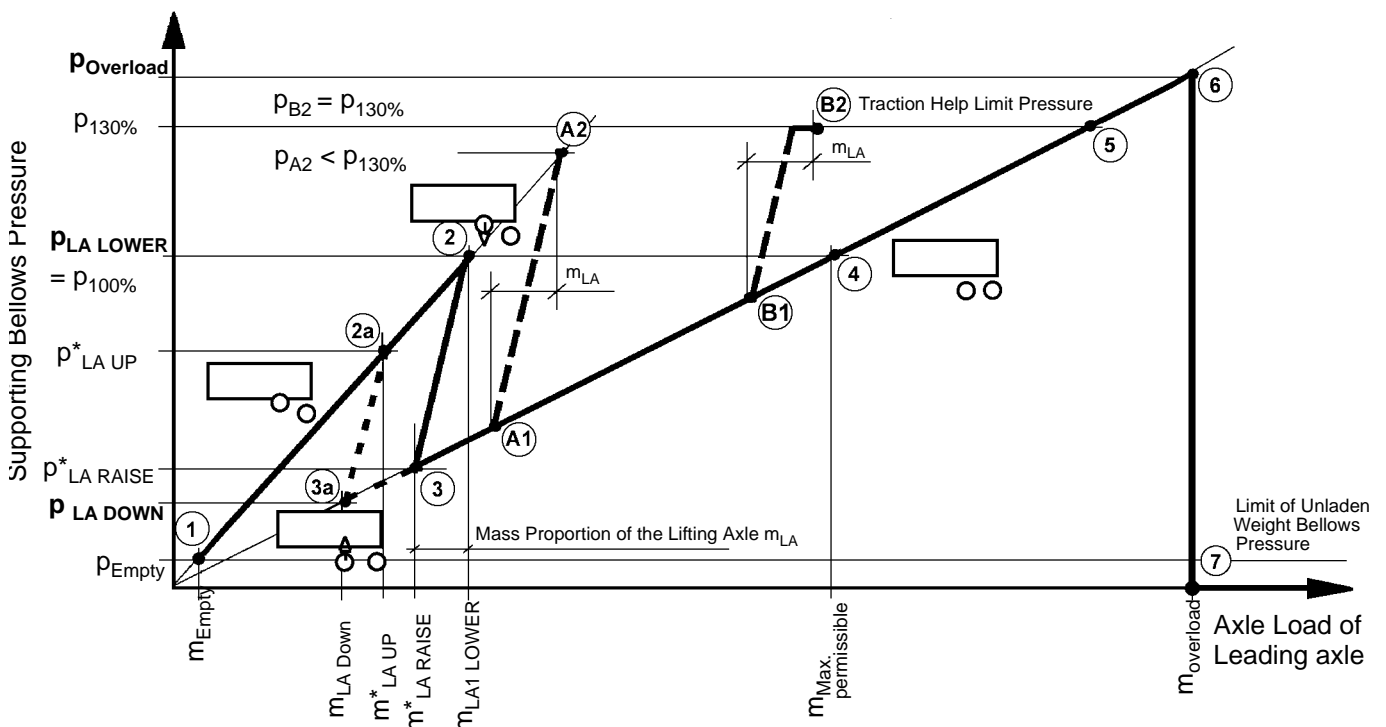

Fig. 3 Lifting Axle Function for Trailers with one Lifting Axle

3. When the lifting axle has been lowered, the load values change. The load is reduced by the lifting axle mass m_{LA} . The pressure in the leading axle's supporting bellows also falls as the axle load is distributed across the supporting bellows of the main and lifting axles. The bellow pressure curve runs from Point ② to Point ③. The resulting pressure in the supporting bellows, $p_{LA\ DOWN}^*$, thus cannot be influenced by the user.
4. As the tanker is filled further, the pressure in the leading axle's supporting bellows again rises to its maximum permissible value, Point ④.
5. It goes through the maximum permissible pressure for the bellows on the supporting axle when traction help is activated, $p_{130\%}$ Point ⑤.
6. Finally it reaches a pressure $p_{Overload}$ ⑥ at which overload protection commences.
7. Overload protection means that when this pressure $p_{Overload}$ is reached, the pressure in the supporting bellows of all axles which are in contact with the ground is reduced and the vehicle's superstructure is lowered until it sits on the buffer, Point ⑦. This is to prevent the vehicle being driven as long there is an excessive load on the superstructure. Any further increase in the load takes place while the supporting bellows are evacuated. The ECU must be informed of the pressure value for $p_{Overload}$. For this purpose, the axle manufacturer's data and any legal provisions on the vehicle's weight must be taken into account.
8. The supporting bellows will not be filled again until the axle load falls below the pressure $p_{Overload}$ once more, e.g. as a result of unloading the vehicle or of reducing the pressure. That means, when the pressure in the supporting bellows is reduced when locked at Point ⑥. Switching the ignition OFF and ON again is sufficient to fill the supporting bellows.
9. Continuing with the above example, the pressure in the supporting bellows falls below ③ when more liquid is drained from the vehicle's superstructure (3a). At this point the pressure in the supporting bellows on the leading axle is so low that it makes sense to raise the lifting axle. Let us call this pressure in the supporting bellows on the leading axle $p_{LA\ Raise}$. It has to be stored in the ECU as part of the procedure for setting the parameters.

For proper Functioning of this Feature, the following Rules must be observed:

- $p_{Empty} < p_{LA\ Raise} < p_{LA\ Lower} < p_{130\%} < p_{Overload}$ (control condition)
- $p_{LA\ Lower} \leq p_{100\%}$
- $p_{LA\ Raise} = 0,9 * p_{LA\ Lower} * (\text{number of nonraised axles} / \text{total number of axles})$ at 2 lifting axles working in parallel 0,8 *...



If these requirements are not taken into account, malfunctions of the lifting axle (e.g. continuous raising and lowering) may occur.

10. When the raising pressure has been reached, the lifting axle is raised and the supporting bellows on the leading axle alone support the axle load. The lifting axle mass proportion m_{LA} now again forms part of the load. The pressure curve for the supporting bellows runs from ③a to ②a where the resulting pressure in the supporting bellows $p_{LA\ UP}^*$ cannot be influenced.
11. Now the unloading process has been fully completed, the pressure curve for the supporting bellows is once again at point ①.

Summary

The user can set up the control of a lifting axle, including overload protection, by setting the following:

- Lowering pressure of the lifting axle $p_{LA\ DOWN}$
- Overload protection pressure $p_{Overload}$
- Raising pressure of the lifting axle $p_{LA\ UP}$

These setting pressures are pointed out in fig. 3.

Fig. 4 and 5 show an unloading and loading process for a semi-trailer with one lifting axle and one with two lifting axles working parallel.

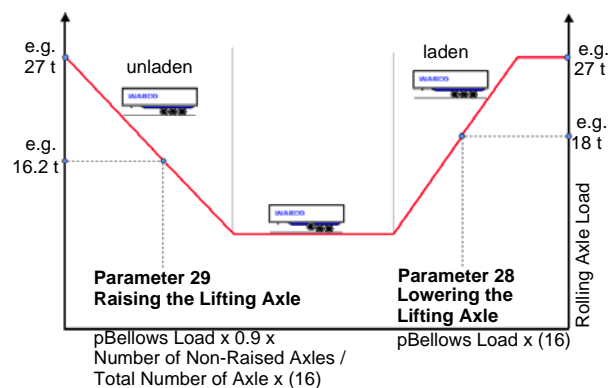

Fig. 4 Control of one Lifting Axle

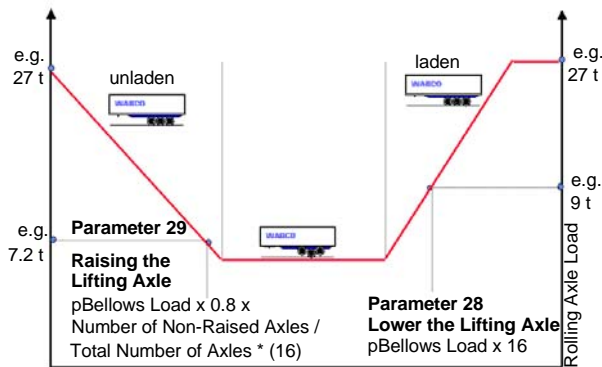

Fig. 5 Control of two Lifting Axles operating in parallel

5.2.2 Traction Help

Generally the traction help facility can be used only if the pressure in the supporting bellows as shown in the fig. 3 between (3a) and (6) can be associated. That means that the lifting axle must be down. The description follows the requirements of EC Guideline 97/27/EC (EC 97/27).

Fig. 3 uses two examples, starting at Points (A1) and (B1), to show how the traction help works for the different load conditions.

Example 1

In point (A1) the pressure in the supporting bellows of the lifting axle is evacuated completely. The lifting axle is raised in the process.

One supporting bellows pressure creates itself onto the leading axle lies on the elongation of the line between (1) and (2) and is described with (A2). After deactivation of the traction help, the pressure in the supporting bellows will once again be as shown in (A1).

The weight resting on the leading axle as a result of traction help being activated is limited by EC 97/27. The axle load must not exceed the lower of that laid down by the axle manufacturer or applicable maximum axle load as defined by law (in Germany, this is defined in section 34 of the Motor Vehicle Construction and Use Regulations (StVZO)) by more than 30%. In addition, it must be ensured that after activating traction help, the residual axle weight on the front axle of the motor vehicle is more than 0.

The maximum permissible pressure in the supporting bellows on the leading axle when traction help is activated, i.e. $p_{130\%}$, which meets these requirements must be stored in the ECAS-ECU when the parameters are set. To allow the system to actuate in condition, a control range $\Delta p_{130\%}$ must be stored in the ECU within which limiting pressure for the traction help, $p_{130\%}$ is controlled.

If traction help and overload protection are to be provided for an ECAS system, the following rule applies:

1. $p_{\text{LA Lower}} < p_{130\%} < p_{\text{Overload}}$ (control condition)
2. $p_{130\%} \leq p_{100\%} * 1.3$
3. $p_{130\%} = p_{\text{LA Lower}} * 1.3$

The control range $\Delta p_{130\%}$ is only effective below $p_{130\%}$.

! According to applicable law, traction help may only be effective at speeds below 30 km/h.

Example 2

The second example shows the behaviour when the traction help limiting pressure $p_{130\%}$ is reached. Starting at (B1) the process of evacuating the supporting bellows of the lifting axles begins again. When the traction help limiting pressure is reached, evacuation of the lifting bellows stops and the pressure in the supporting bellows of the leading axle does not increase any further (B2). In this case, the lifting axle stays down. The excess load is taken up by the supporting bellows of the lifting axle. After deactivation of the traction help, the pressure in the supporting bellows will once again be as shown in (B1).

To summarize, the following values have to be stored in the ECU for the traction help facility:

- max. permissible pressure in the leading axle's supporting bellows when traction help is activated $p_{130\%}$ (traction help limiting pressure),
- Control range $\Delta p_{130\%}$ ("pressure hysteresis"),
- Limiting speed for traction help.

In addition, parameters can be set for the times applicable to the length of actuation and the intervals between actuations. However, these parameters are of a subordinate nature for traction help control as such.

Example calculation

This example shows lifting axle control being set for one lifting axle on a 3-axle semi-trailer with ABS-VCS/ECAS. The reference plate for the load sensing valve shows that the bellows pressure p_{Empty} for the unladen vehicle is 0.7 bar and $p_{100\%}$ is 4.7 bar for the laden vehicle. The lowering pressure for the lifting axle $p_{\text{LA Lower}}$ is to be equal $p_{100\%}$. If we follow the rules for the traction help and the overload pressure, we arrive at the following pressures:

- $p_{\text{Empty}} = 0.7$ bar
- $p_{\text{LA Lower}} = p_{100\%} = 4.7$ bar
- $p_{130\%} = 4.7 \text{ bar} \times 1.3 = 6.11$ bar
- $p_{\text{LA Raise}} = 0.9 \times 4.7 \text{ bar} \times 2/3 = 2.82$ bar

The control condition is being met, because $0.7 \text{ bar} < 2.82 \text{ bar} < 4.7 \text{ bar} < 6.11 \text{ bar}$ applies.

Such a calculation is used to establish standard values. These may be adjusted individually although the control conditions have met in order to ensure proper operation.

5.2.2.1 Trailing Axle Control (Manoeuvring Aid)

If traction help is used to reduce the load on an axle and to shift it to the driving axle of the motor vehicle in order to improve its traction. A manoeuvring aid has a different purpose. It is used on the very rear axle of a semi-trailer to:

- Reduce tyre wear,
- Achieve tighter turning circles by manoeuvring at low speeds.

This is sufficient for some applications and is a viable substitute for an expensive steering axle.

! The pneumatic and electrical circuits for such applications are shown in diagrams in chapter 12 "appendix".

Pneumatic Port 25 leading to the lifting bellows is closed for this purpose.

To reduce the load on the axle only when manoeuvring aid is active and to allow it to stay in contact with the ground at all times:

- Select Parameter 28 (lowering the lifting axle) which lies below the empty bellow pressure for the vehicle.
- Select Parameter 29 (raising the lifting axle) an even lower value is selected (50% of Parameter 28); these values are stored in counts.

The manoeuvring aid also uses the same time, speed and pressure monitoring processes as the traction help:

- Set all other parameters as for a conventional traction help system.

! For 3-axle semi-trailer, the combination of a traction help on the first axle and a manoeuvring aid on the third axle is also shown in the annex.

5.2.3 Control Algorithm for Lifting Axle Control (two separate Lifting Axles)

Before describing how two separate lifting axles are controlled, the following basic facts must be mentioned:

The 1st lifting axle is usually actuated by the block of ECAS solenoid valves for rear axle/lifting axle. This is the lifting axle:

- which is served from plug-in connector X19/X20 on the ECU.
- which is the second axle to be lowered when the unladen vehicle is being loaded.

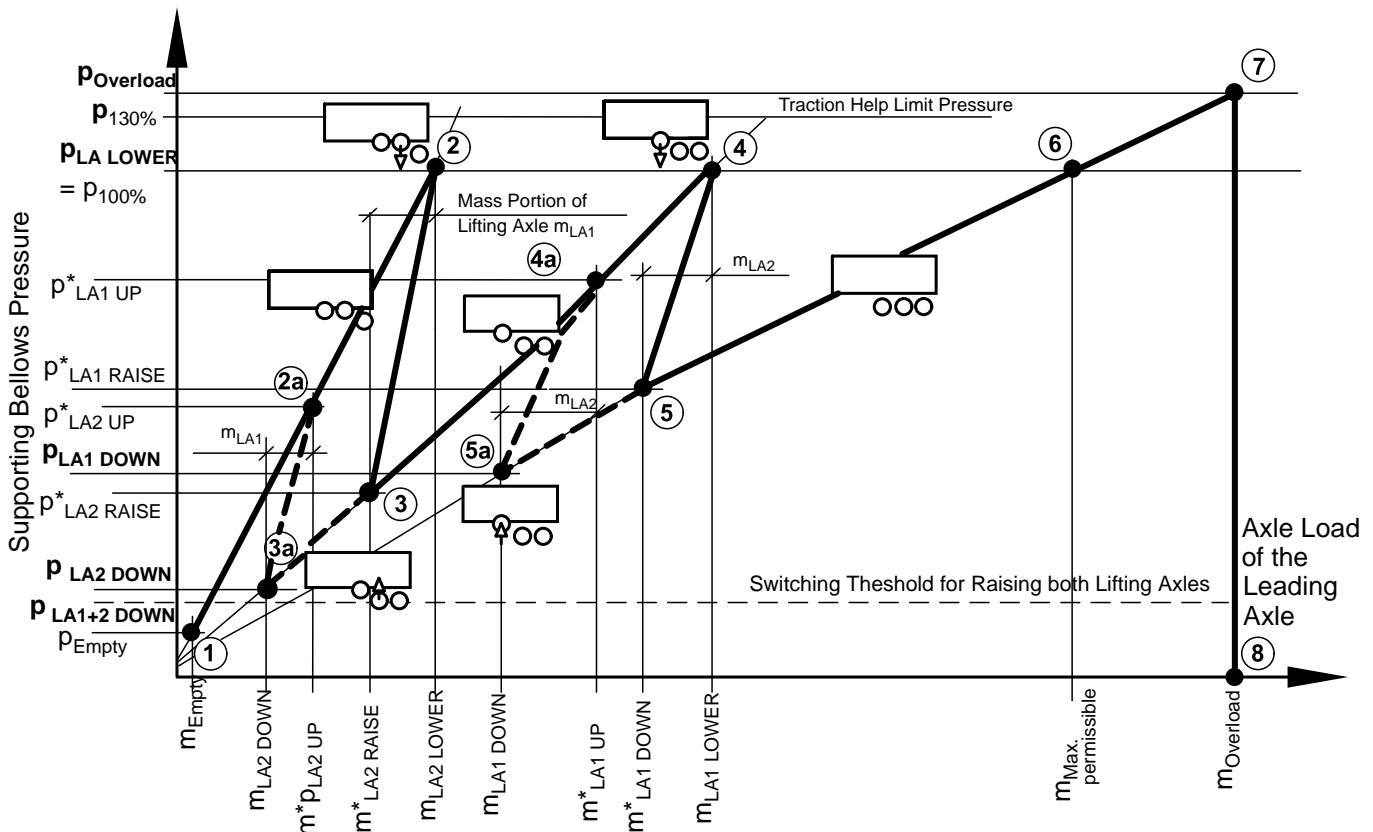

Fig. 6 Lifting axle function for trailers with two separately controlled lifting axles

- which is the first axle to be raised when the vehicle is being unloaded.
 - whose load is reduced when traction help is activated.
- The arrangement and the function of the 1st lifting axle are similar to those of systems with one lifting axle only.

The 2nd lifting axle is always actuated by a separate spring-returned valve. This is the lifting axle which:

- is served from plug-in connector X16 on the ECU.
- is the first axle to be lowered when the unladen vehicle is being loaded.
- is the second axle to be raised when the vehicle is being unloaded.
- is not actuated when traction help is activated.

Lifting axle control with two separated lifting axles is based on a lifting axle control with one lifting axle. The behaviour of the 1st lifting axle when two separate lifting axles are to be controlled is identical to that of the system for controlling one single lifting axle.

In both cases, the 1st lifting axle is actuated by the block of ECAS solenoid valves.

In the form of the bold line, the diagram (Fig. 6) shows the course of the pressure in the supporting bellows on the trailer's leading axle as a function of the trailer's load.

For systems with two lifting axles, a system for one lifting axle is extended in such a way that as the vehicle is being loaded, the second axle is lowered first when the lowering pressure has been reached. ECAS will then check for 30 seconds whether the pressure remains below that lowering pressure level. If this is not the case, the 1st lifting axle is also lowered after a delay of 15 seconds. In all other respects, the control process is similar to that described for systems with one lifting axle only.

No essential changes are required for utilizing the traction help. It is the 1st lifting axle which takes over this function.

When the vehicle is being unloaded, the 2nd lifting axle is raised last.

The raising pressure selected for the 2nd lifting axle must be smaller than that for the 1st lifting axle as it is to be raised after the 1st lifting axle. The function of the 2nd lifting axle is achieved between the time when the vehicle is empty and the time when control of the 1st lifting axle takes place.

A pressure must be defined in the range between empty bellows pressure and the raising pressure for the 2nd lifting axle as the switching threshold for raising both lifting axles. If the pressure falls below that threshold and both lifting axles are down (e.g. with ignition OFF), they are

both raised simultaneously. Above that switching threshold and below the raising pressure for the 2nd lifting axle, it is the 2nd lifting axle which is raised first, followed by the 1st lifting axle being raised after a delay of 15 seconds.

For properly setting the pressure parameters for raising and lowering the lifting axles, the following rules should be adhered to:

1. $p_{\text{Empty}} < p_{\text{LA1+2 Raise}} < p_{\text{LA2 Raise}} < p_{\text{LA1 Raise}} < p_{\text{LA Lower}} < p_{130\%} < p_{\text{Overload}}$ (control condition)
2. $p_{130\%} \leq p_{100\%} \times 1.3$
3. $p_{130\%} = p_{\text{LA Lower}} \times 1.3$
4. $p_{\text{LA Lower}} \leq p_{100\%}$
5. $p_{\text{LA1 Raise}} = 0.9 \times p_{\text{LA Lower}} \times (\text{number of non-lifted axles} / \text{total number of axles})$
6. $p_{\text{LA1+2 Raise}} = 0.8 \times p_{\text{LA Lower}} \times (\text{number of non-lifted axles} / \text{total number of axles})$
7. $p_{\text{LA2 Raise}} = p_{\text{LA1+2 Raise}} + 0.5 \text{ bar}$

After unloading, the pressure curve for the supporting bellows is once again at Point ①.

Summary

The user can establish control for two lifting axles, including traction help and overload protection, by entering the following:

- Overload protection pressure p_{Overload}
- Traction help pressure $p_{130\%}$
- Lowering pressure for lifting axles p_{LALower}
- Raising pressure for 1st lifting axle p_{LA1Raise}
- Raising pressure for 2nd lifting axle p_{LA2Raise}
- Raising pressure $p_{\text{LA1+2 Raise}}$ at which both the 1st and the 2nd lifting axles are raised.

! The basic conditions for properly establishing lifting axle control must be taken into account.

Example calculation

This example shows the setting for lifting axle control on a 3-axle semi-trailer with ABS-VCS/ECAS for two separate lifting axles.

The reference plate for the load sensing valve shows that the bellows pressure p_{Empty} for the unladen vehicle is 0.7 bar and $p_{100\%}$ is 4.7 bar for the laden vehicle.

The lowering pressure for the lifting axle p_{LALower} is to be equal $p_{100\%}$. If we follow the rules above, for properly setting the pressure parameters for raising and lowering the lifting axles, the following pressures values are achieved:

- $p_{\text{Empty}} = 0.7 \text{ bar}$

- $p_{LA\ Lower} = p_{100\%} = 4.7\ \text{bar}$
- $p_{130\%} = 4.7\ \text{bar} \times 1.3 = 6.11\ \text{bar}$
- $p_{LA1\ Raise} = 0.9 \times 4.7\ \text{bar} \times 2/3 = 2.82\ \text{bar}$
- $p_{LA1+2\ Raise} = 0.8 \times 4.7\ \text{bar} \times 1/3 = 1.25\ \text{bar}$
- $p_{LA2\ Raise} = 1.25\ \text{bar} + 0.5\ \text{bar} = 1.75\ \text{bar}$

Such a calculation is used to establish standard values.

These may be adjusted individually although the control conditions have met in order to ensure proper operation.

Fig. 7 shows the unloading and loading of a vehicle with two separate controlled lifting axles.

The control condition is being met, because $0,7\ \text{bar} < 1,25\ \text{bar} < 1,75\ \text{bar} < 2,82\ \text{bar} < 4,7\ \text{bar} < 6,11\ \text{bar}$ applies.

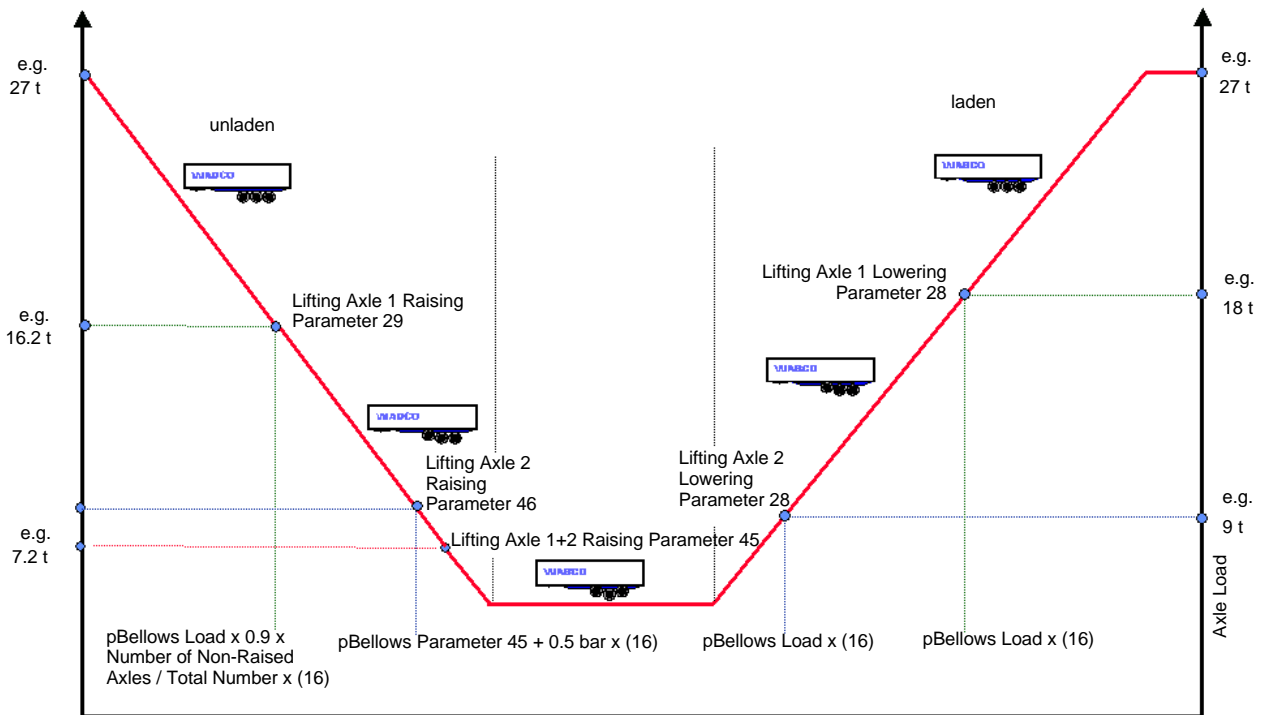

Fig. 7 Control of two Lifting Axles operating separately

The switching point for simultaneously raising lifting axles 1 and 2 (Parameter 45) lies below raising lifting axle 2 (Parameter 46)

$p_{Bellows\ laden} \times 0.8 \times \text{Number of Non-Liftable Axles} / \text{Number of Axles} \times (16)$ (only when the whole load is put down abruptly or unladen vehicle + ignition ON)

6. Tyre Deflection Compensation

The final topic regarding the control systems covered by ECAS concerns the process of compensating for tyre deflection. That means that the tyre deflection which varies as the load on the trailer changes is added to the distance between the vehicle's axle and its superstructure. This only applies to the setting of a driving level, i.e. when the vehicle is being driven. Thus the distance between the vehicle's superstructure and the road surface is the same at all times. This control system may be desirable if the overall height of the trailer is close to the maximum defined by law. Usually, however, it is not required.

This control can be implemented with ECAS systems. It is optional. Basic requirements are the presence of a height sensor and pressure sensor. The reference level is increased. Any changes in load cause the reference value to be changed.

Prior to implementing this control system, the differences in tyre deflection between the unladen and the fully laden vehicle and for the tyres to be used must be known or established. Thus the unladen vehicle, with the pressure for the supporting bellows of p_{Empty} can have a tyre deflection $\Delta r_{0\%}$ allocated, and the vehicle carrying a maximum load and a pressure for the supporting bellows pressure $p_{100\%}$ can have a tyre deflection $\Delta r_{100\%}$ allocated. The difference, $\Delta r_{100\%} - \Delta r_{0\%}$, represents the adjustment area within which the driving level is controlled as a ratio of the load.

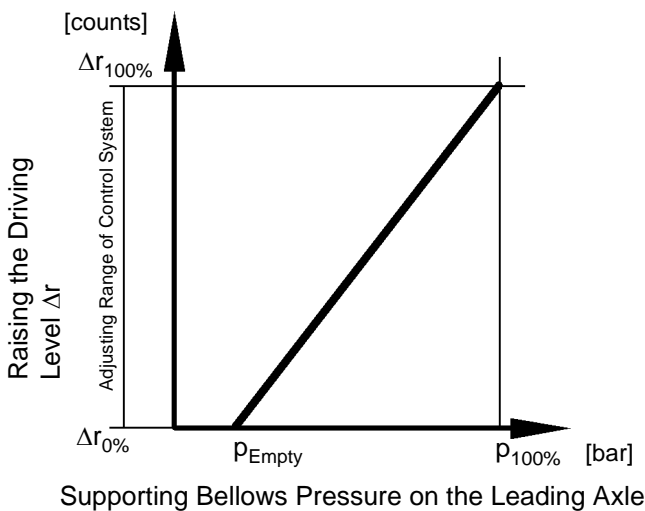

Fig. 8 Linear control to axle load

- The prime values must be stored in the ECU as part of the procedure for setting the parameters.

The ECU then uses them to compute the increase in the reference value for the driving level.

! If the allocation of prime values do not fit to used tyres, unexpected adjustments in the driving level may result.

The control process is achieved as follows. The pressure in the supporting bellows of the leading axle is ascertained when the "driving level" reference value is specified. The ECU can then use this pressure p , together with the values stored for tyre deflection, to compute a reference value for the driving level which is higher by Δr and to provide this to the system as the new reference value for the driving level.

Then, the same control procedure starts like already described in chapter "Basic Functions":

1. The height sensor determines the actual distance between the vehicle's superstructure and its axle and compares this to the new reference value just computed.
2. In the event of any control deviation, the actuator (solenoid valve) receives an adjustment signal.
3. The pressure in the supporting bellows on the leading axle is increased or decreased accordingly.
4. This causes the distance between the vehicle's axle and its superstructure to change.

Within the process of the change in the distance, the pressure in the supporting bellows remains constant, i.e. there is no further change in the reference value as a result of the readjustment.

Only changes in the load result in changes in the pressure in the supporting bellows.

Summary

An increasing driving level can be initiated with following adjustments:

- Supporting bellows pressure p_{Empty} for the unladen vehicle,
- Tyre deflection $\Delta r_{0\%}$ for the unladen vehicle,
- Supporting bellows pressure $p_{100\%}$ for the fully laden vehicle,
- Tyre deflection $\Delta r_{100\%}$ for the fully laden vehicle.

The feature for compensating for tyre deflection is not operational when traction help has been activated.

7. System Configuration

ECAS is a system of modular design, thereby allowing trailers to be fitted with a system specified designed for their operation. The selection of the system components to be used is determined by how the system is expected to perform.

This modular design is illustrated by an example circuit diagram for ECAS system (1-point control) on a trailer (equipped with ABS-VCS) with a remote control unit. (↓ Fig. 9)

The ECU offers several different options for supply/activation/diagnostic.

In this example, the power supply is provided via the diagnostic port of the ABS-ECU (VCS). Depending on the equipment fitted, it can also be provided via DIA/ECAS/ISS output port of the EBS-ECU (More information on this is found later in this section.).

The power supply could also be provided from ABS-ECU (Vario C). The power supply will be explained in more detail below.

Optionally, it could be connected to the stop lamp. The control procedure is suspended while the brakes are being applied.

A remote control unit may be provided on the trailer to control the superstructure's movement. Even the use of additional remote control units is possible (such as on motor vehicles). In this case, a changeover switch must be provided in the data line because otherwise the ECAS ECU can only communicate with one remote control unit at any one time.

It is necessary to arrange for a diagnostic port for diagnostic work on the ECAS and ABS or EBS system. Usually the diagnostic port is included in ECAS.

There are even more possibilities in the ECU for the control circuit. Between 1 and 3 height sensors can be connected here.

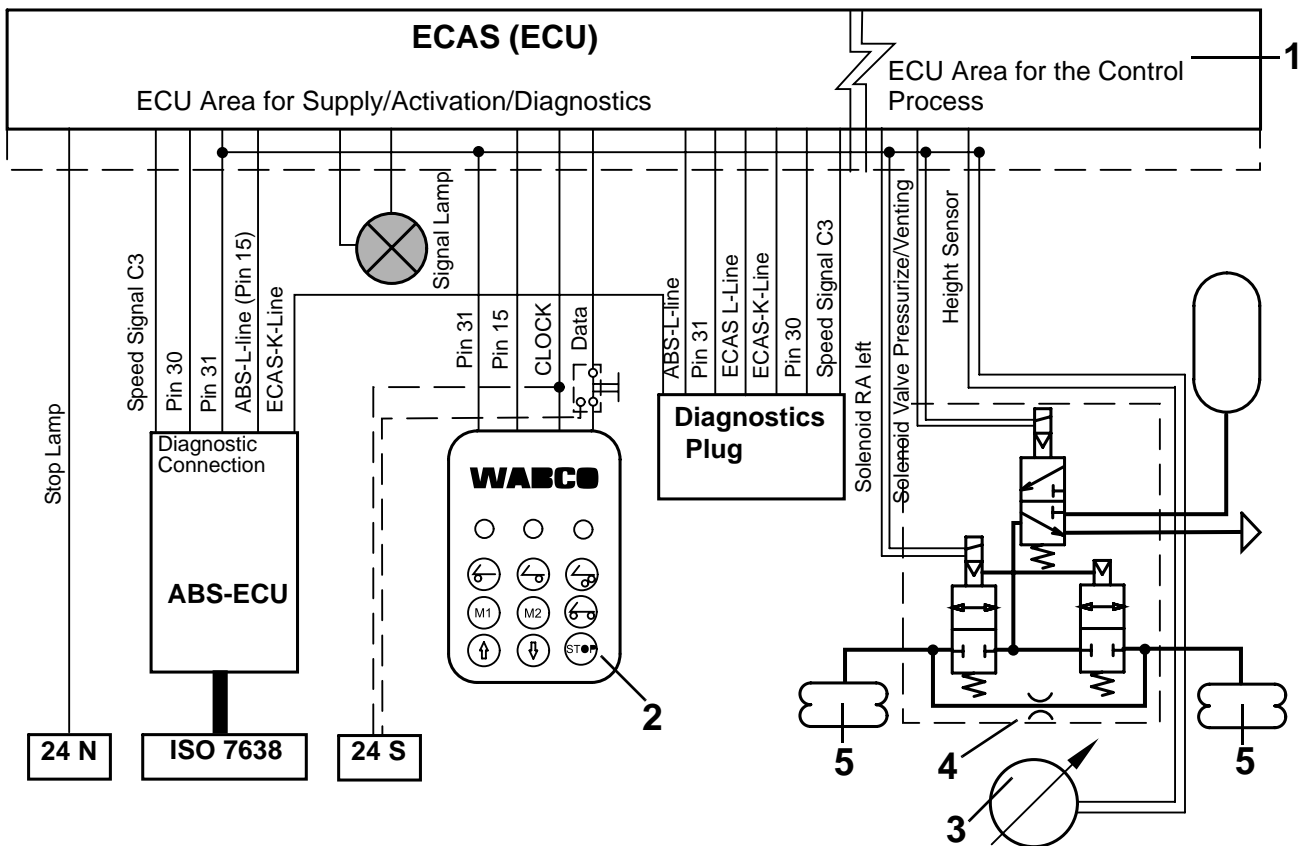

1 ECU
2 Remote Control
3 Height Sensor
4 Solenoid Valve
5 Bellow

Fig. 9 Wiring Example for ECAS System (1 Height Sensor Control) in a Trailer (applied with ABS - VCS) with Remote Control

! It is important to remember that at least one height sensor is required and up to two height sensor are permissible per axle or per axle assembly.

Axle unit will say, a pair of two leading axles is handled as one axle.

One height sensor means one control circuit for levelling control. Systems with two height sensors can be designed in such a way that the control circuits operate separately by side or by axle.

7.1 Control in the Trailer

7.1.1 1-Point Control

A 1-point control is used a a standard for semi-trailers and central-axle trailers. Even if the trailer has got three axles, one height sensor on the middle axle is enough.

7.1.2 2-Point Control

A 2-point control is used at the rear axle or on semi-trailers:

- If the used axle unit more smooth is used.
- For specific actuation of the individual supporting bellows (left/right control).
- For great track widths.
- If the load is expected to be spread unevenly.
- If the centre of gravity is very high.

These vehicles are mostly fitted with very rigid axles. The usage of two 2-point control would result in a distortion of the axles against the forces of the air spring.

7.1.3 3-Point Control

A 3-point control is mainly used on drawbar trailers. A 1-point control is on the steering axle. A 2-point control is on the rear axle.

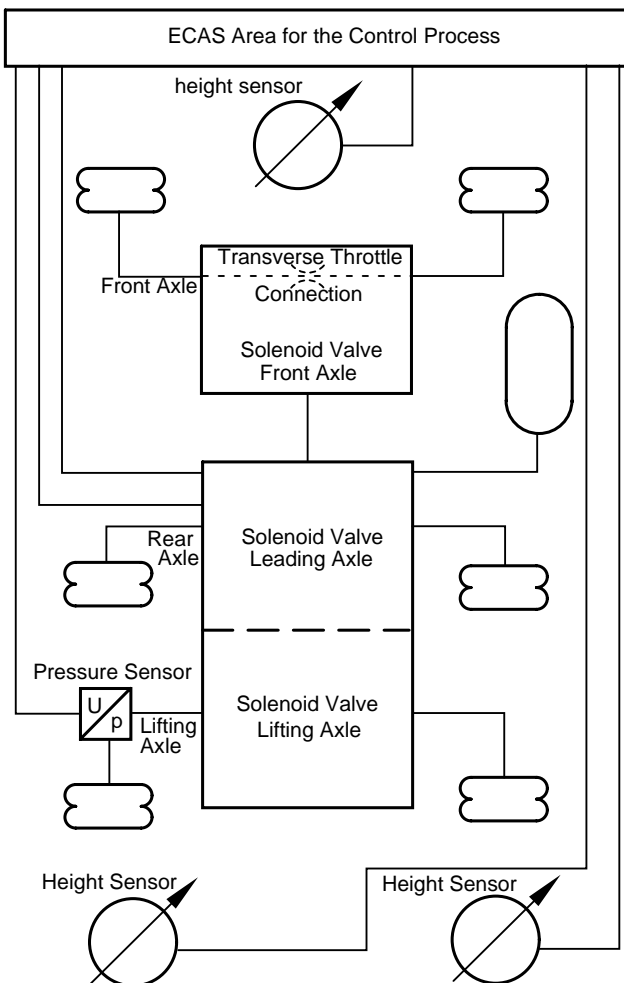

Fig. 10 Vehicle with 2-Point Control on Rear Axle

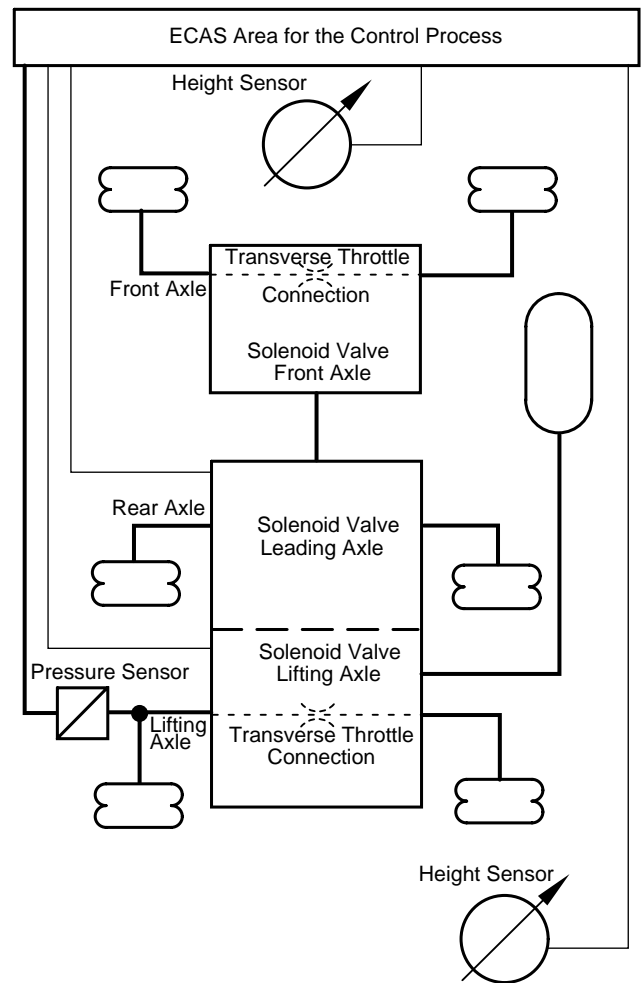

Fig. 11 Vehicle with 1-Point Control on Rear Axle

Fig. 10 and 11 compare the situation of 2-Point sensor and 2-Point sensor axle. The axle with 2 height sensors is always the rear axle. Additionally the connection of lifting axles and front axles is shown. The main difference is the transverse throttle connection, always fitted between the two bellows of the 1-Point axle. Further diagrams for possible connection are to be found in the annex.

Control of Lifting Axles

If the vehicle has one or several lifting axles, the height-sensor configuration can be extended by a pressure switch or pressure sensor.

To automatically lower one or several lifting axles when

the maximum pressure in the bellows of the lifting axle is reached, it is sufficient to fit a pressure switch to determine the pressure in the bellows on the leading axle. If lifting axle control is desired (also known as fully automatic lifting axle control), the pressure on the leading axle must be picked up by a pressure sensor. For using the traction help facility, lifting axle control must have been implemented.

It is likely that WABCO's Electronically Controlled Braking System, EBS, will also be used to an increasing extent on trailers. In the event of the so-called Trailer EBS being used on the trailer, ECAS is easy to install. Compared to the VCS variant, the area of supply/actuation/diagnostics changes.

8. Components

Components of an ECAS System

- Height sensor(s)
- pressure sensor (optional, i.e. their use depends on the type of system chosen)
- Electronic-control unit (ECU)
- ECAS solenoid valve(s)
- Remote control unit (optional)
- Pneumatic components (air suspension bellows; possibly lifting bellows; pressure limiting valves; pipes; compressed air reservoir)

The power is supplied via an upstream ABS or EBS ECU and is thus dealt with separately as part of the description for the ECAS ECU.

8.1 Sensors

The control process begins by sensors. These sensors pick up the Quantities to be controlled and transmitting them to the ECU via the sensor cable.

! The ECAS system must have at least one height sensor.

For controlling additional functions, a pressure sensor is used.

8.1.1 Height Sensor 441 050 011 0

The height sensor continuously picks up any changes in the height of the superstructure. The height sensor detects the position (distance) of an armature within the coil. The inductive measuring principle is used.

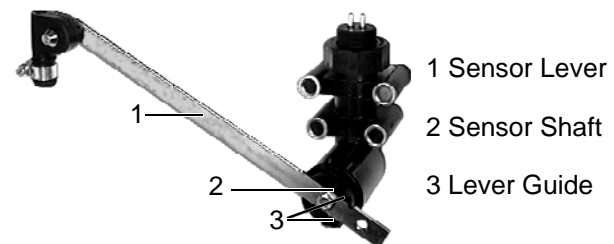

Fig. 12 Height Sensor with Lever Fastened to the Height Sensor's Shaft

A slewing motion applies externally via the lever to the inside of the sensor. This movement, according to the principle of crack gear, is translated free from play into a linear movement of the armature into the coil. The 'dipping movement' of the ferromagnetic armature into the stationary coil causes a phase displacement between current and voltage. The ECU measures the current displacement and converts it into counts.

! The height sensor cannot be functionally tested by using a voltage meter.

If necessary, the coil resistance of the height sensor can be checked. The resistance must be approx. 120 ohm. The coil's induction is evaluated more than 50 times a second by a special evaluation circuit within the ECU. The ECU monitors the proper function.

The height sensor is located on the vehicle's frame near the axle whose air suspension bellows are to be controlled. The master gauge for the holes used for fastening the sensor is identical to that of a conventional air suspension valve.

Steered (front) axles usually have one height sensor (1-point control) above the centre of the axle. (Leading) axles which are always in contact with the ground can have one or even two height sensors fitted.

In order to achieve the best possible control performance for the individual height sensor (2-point control on one axle):

- Fit the sensors as far apart as possible.

The height sensor is firmly attached to the axle to be controlled via a threaded rod. The rod has rubber end pieces acting as dampers and compensating devices.

Important for Installation

The height sensor has a measuring range from + 43° to - 40° starting from a horizontal sensor lever position. Fig. 13 displays the arrangement of the positive and negative areas.

Ideally the whole of the excursion range is used, with the lever being close to horizontal at the normal level. The lever has a 90° angle to the height sensor. This corresponds to 80-100 counts. In this position the normal level is adjusted the best.

! The maximum excursion of the lever (+/-50°) may not be exceeded.

For the lever linkage, a threaded rod is preferable to a smooth rod. This way slipping within the rubber is virtually impossible.

The length of the sensor lever is selectable. However, it must be identical for the height sensors connected to the ECU.

Short sensor lever

A short sensor lever ensures a high resolution of the measured values even when the change in the height is slight. However, it can only cover a small range of settings.

Long sensor lever

A long sensor lever can achieve the opposite, covering a wide range of settings to achieve at the expense of the resolution of measured values. The object should always be the best possible utilization of the excursion angle.

! Bending the lever at right angles must be avoided because this might result in an impermissible tilting torque acting on the sensor shaft. For this reason, all swivelling axes must be in parallel to each other.

There is only one type of height sensor.

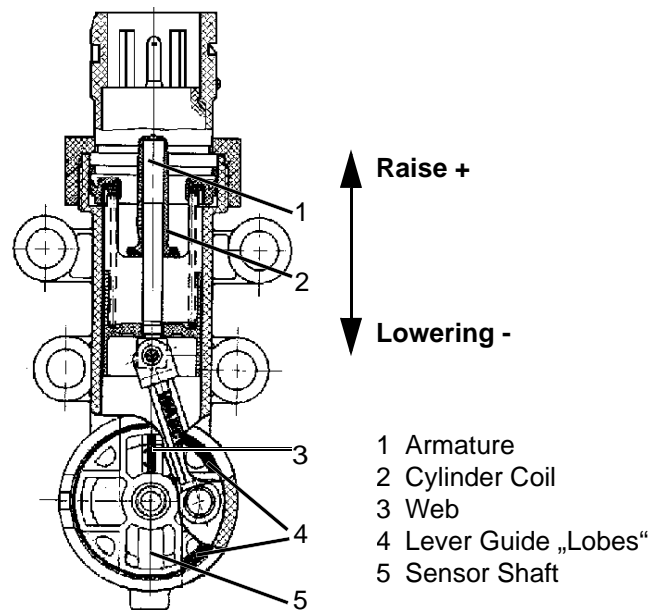

Fig. 13 Cross-Section of Height Sensor

The sensor level can, however, be mounted in steps of 90 degrees on the sensor shaft which can be smoothly turned in the sensor housing. For accurate operation and measured values, the sensor shaft has to be aligned properly.

To facilitate this, two projections (4, ↑ Fig. 13) have been provided on the sensor shaft which are used as lever guides. Those projections point toward the right at right angles to the direction in which the armature moves, or to the left, this permits the best possible utilization of the height sensor's measuring range.

! It is important that the height sensor moves freely across the whole of its operating range, and that the lever can only move in the way intended.

When mounting the height sensor on the vehicle's superstructure, the sensor's raising and lowering reactions must be taken into account.

- The dipping cylinder coil in the RAISE direction increases the induction.
- The dipping cylinder coil in the LOWER direction reduces the induction.

The values measured can be displayed on suitable diagnostic equipment (PC).

- Raising the superstructure causes the display values to be increased.
- Lowering the superstructure causes them to be reduced.

8. ECAS Components

8.1.2 Pressure Sensors

For utilizing pressure-controlled ECAS functions, a pressure sensor must be used. This pressure sensor picks up the pressure in the supporting bellows on the axle which is always in contact with the ground (on the trailer this is usually a rear axle) in order to:

- Control a lifting axle;
- Traction help,
- Compensate for tyre deflection.

The pressure is detected by means of extension measuring strips. As the pressure is increased, the resistance at a Wheatstone bridge changes, this in turn generating a voltage as a ratio of the pressure. Depending on the type of pressure sensor used, it is energized with 8 ... 32 volts. Via a signalling line (sensor cable) the voltage generated by the pressure is transmitted to the ECU.

In a pressureless condition (pressure sensor offset), the output is 0.5 volts.

The transmittable voltage at the upper limit of the measuring value at a pressure of 10 bar is 4.5 volts (pressure sensor type with bayonet connector to DIN 72 585-A1-3.1 - in short DIN bayonet) or 5.5 volts (pressure sensor type with bayonet - older version).

! The maximum permitted pressure of 16 bar for these pressure sensors may not be exceeded.

The output of measuring values is done in digital form, i.e. in steps. The values measured can be displayed on suitable diagnostic equipment (PC).

If ECAS has been installed together with EBS, no separate pressure sensor needs to be fitted for ECAS. The pressure sensor signals from EBS are also used for ECAS.

EBS transmits the data to the ECAS system via the K-line. This means that the ECAS-ECU evaluates pressure sensor data even if the system does not use lifting axle control or compensation for tyre deflection. If a pressure sensor is fitted nonetheless, the signals for the ECAS pressure sensor will have priority over the data transmitted from the K-line.

The pressure sensor is connected to a separate connector on the supporting bellows or on a T-piece on the bellows' inlet port.

! The pressure sensor should never be fitted in the air line between the supporting bellows and the ECAS solenoid valve. Due to the great dynamic forces ensuing from increasing and decreasing the pressure could cause measuring errors.

Older systems provided for the installation of two pressure sensors; however, this was never implemented. It has turned out, that the existence of one pressure sensor is sufficient for the desired control process. At present there are two different types of pressure sensor variants used in Trailer ECAS.:



Fig. 14 Pressure Sensor 441 040 003 0

Pressure Sensor 441 040 003 0 with bayonet connection for the sensor cable. The smallest digital measuring steps are 1/20 bar. 1 bar would equal 20 measuring values. This type of pressure sensor is increasingly being replaced by the type described below.



Fig. 15 Pressure Sensor 441 040 (007)/013/015 0

Pressure Sensor 441 040 (007)/013/015 0 with DIN bayonet for the sensor cable. The smallest digital measuring steps are 1/16 bar. 1 bar would equal 16 measuring values. Because of its standardised DIN connection, this type of pressure sensor is being used to an increasing extent on trailers (also by EBS) and will replace the variant described above.

- When replacing the pressure sensors it becomes necessary to change the parameters in the ECU which affect the pressure related control process. (↓ 11.1 Fitting a new ECU and 11.3 Component Replacement).

Signalling line 4

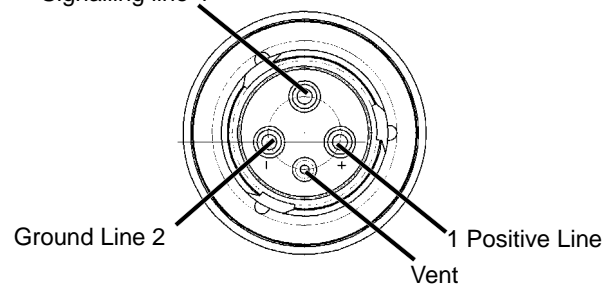

Fig. 16 Port Allocation Pressure Sensor 441 040 003 0 (Bayonet Type)

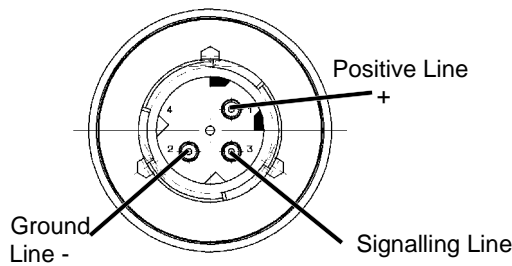

Fig. 17 Port Allocation Pressure Sensor 441 040 (007)/013/015 0 (DIN Bayonet Type)

8.2 Electronic Control Unit (ECU) 446 055 ... 0

The Electronic Control Unit is the heart of the ECAS system. The power for the ECAS-ECU is supplied from the ABS- or EBS-ECU.

The control process for the air suspension is coordinated in the ECAS-ECU. This means:

- All incoming signals from the height sensors are continuously monitored, converted into computer-legible signals (these signals being called counts) and evaluated;
- If the system configuration comprises a pressure sensor, these incoming signals are also continuously monitored, converted into computer legible signals (counts) and evaluated;
- Depending on the parameters set, and on the design of the system, the signals are determined for controlling the reference values in the air suspension bellows and transmitted to the ECAS solenoid valves;
- All data for which parameters have been set, which have been calibrated or otherwise defined (e.g. memory levels), are stored and managed.
- Any error perceived are stored and displayed via the signal lamp on the trailer, if applicable. They can be read out using the appropriate software;
- The appropriate software can be used for setting the parameters and for calibrating the system; Parameterizing and calibrating require a training;
- Exchanging data with the remote control unit and performing certain monitoring functions.

In order to ensure swift control reactions to any changes in actual values, the microprocessor performs cyclic processing of a firmly installed programme within fractions of second (25 milliseconds). One programme cycle meeting all the above requirements. This programme is firmly written into a programme module (ROM).

However, it uses numerical values (parameters) which

are stored in a programmable memory. These parameters affect the computing operation and thus the control reactions of the ECU. They are used to transmit the system configuration and the other preset values concerning the vehicle and functions to the computer programme.

The ECU is sited on the Trailer's frame, preferably in the vicinity of the ABS- or EBS-ECU in a protective housing. This protective housing is similar to the ABS-VARIO C system. The cable of the ECAS system lead through holes in the side of the housing to a base plate inside.

! The ECU does not need to be opened for diagnostic purposes.

The ECU does have to be opened when:

- the system is being installed or modified to attach connectors for ECAS components to the base plate or to remove components from the base plate;
- checking the paths leading to the connected ECAS components.

When the ECU has been opened, the base plate is visible (↓ Abb. 18). The actual electronics are located behind the base plate and are thus inaccessible.

The diagnostic socket shared by ABS or EBS and ECAS for the diagnostic cable is located on the underside of the ECAS housing, or on the vehicle's frame.

ECU Variants for Use on Trailer



Fig. 18 Base Plate of ECU 446 055 060 0

446 055 060 0

Standard version for all trailers with ABS VARIO C. Can also be used for VCS. Version 446 055 065 0 is preferred.

! Not for new vehicles.
Has been discontinued since early 1999.

446 055 065 0

Standard version for all trailers with ABS. Replaces variants 446 055 060/070 0.

8. ECAS Components

446 055 066 0

Standard version for all trailers with EBS.

446 055 070 0

Version with reduced functional scope for semi-trailers (1-point control; no lifting axle) with ABS VARIO C (can also be used for VCS) Version 446 055 065 0 is preferred. On the basis of ECU 446 055 060 0.

- ! Not for new vehicles!
- ! Has been discontinued since early 1999.

Fig. 19 shows the cover of the protective housing available for establishing the connections after it has been folded back from the lower part of the housing. The cover is 'upside-down'.

- The drain holes (1) for any condensation water which may have collected in the housing at the top; when the housing is closed, these have to point downwards.
- The sticker in the top right-hand corner shows the assignment for plug-in connections (2).
- The inside of the cover shows the base plate with 20 consecutively numbered plug-in connectors (3). It is into these plug-in connectors where the plugs with the connecting cables of the individual ECAS components are pushed.
- Next to plug connector X3 there is a 10 amps fuse against ABS or a 5 amps fuse against EBS (4).

- The sticker shows the assignment of the plug-in connectors (5) on the base plate.

8.2.1 Installation

- The installation begins by identifying a suitable place to site the ECU.

- ! The cable fittings have to be on the side of the housing.

The lower part of the ECU's housing should be sited such that:

- The ECU does not lie in the direct spray by the tyre.
- The ECU does not lie in the direct stones thrown by the tyre.
- It is easily accessible for diagnostic purposes.

- ! The drilling dimensions for the lower part of the ECU's housing can be found on the housing's back.

- For mounting the ECU's housing, Ø 8 mm holes should be drilled for the M 6 bolts provided.

This should provide adequate location tolerance even if one of the holes is slightly off centre.

- ! **Prevent Corrosion:**
 - Paint the holes.
 - Trim the holes. This prevents from injuries.

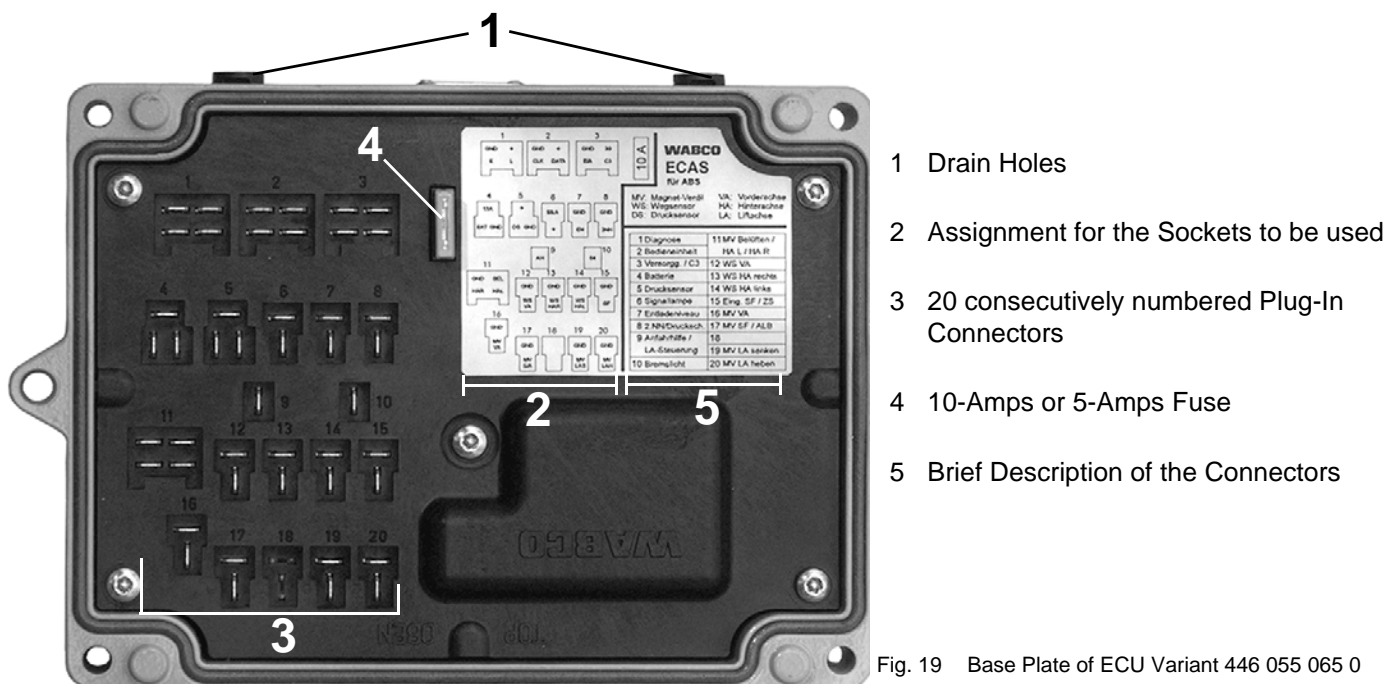

Fig. 19 Base Plate of ECU Variant 446 055 065 0

! Prevent electro-chemical reactions due to moisture:

- Steel screws, even when zinc coated should be wax treated or sprayed when in contact with aluminium.
- When screwing the ECU to the lower part of the housing using the 4 hexagon socket screws supplied.

! Make sure that no water or dirt can get into the housing.

- Make sure there is no gap between the cover and the housing.

The seal is not available as a spare part. If the seal has been mechanical damaged the WABCO warranty is no longer valid.

! Never use pointed objects e.g. scissors or screw driver to check the deepness or deformation of the seal.

On both sides of the WABCO name plate you can see a 'labyrinth' seal made of rubber (5, ↑ Fig. 19).

The semi-circular opening allowing the ECU to breathe. The open drainage hole must point downwards. The installation position therefore is defined. The lower part of the housing is a surface treated aluminium casting. It has threaded port for the screw-in unions (PG 11).

- Those ports not used are sealed using rubber seals and blanks.

The latest version of the lower part of the housing has predefined ports in the casting which can be opened using a mandril as needed.

Advantages:

The time required and the risk of error when sealing the non-used ports are minimized.

- The housing should always be mounted using a tightening torque of 0.8 - 1 Nm.

Entry of Cable into the ECU Housing

- Cables must always approach the ECU assembly from below.

The reason for this is to prevent external water from 'creeping' along the sheath of the cable to the seal and collect there. Otherwise the cables need a water trap as shown on the right (↓ Fig. 20).

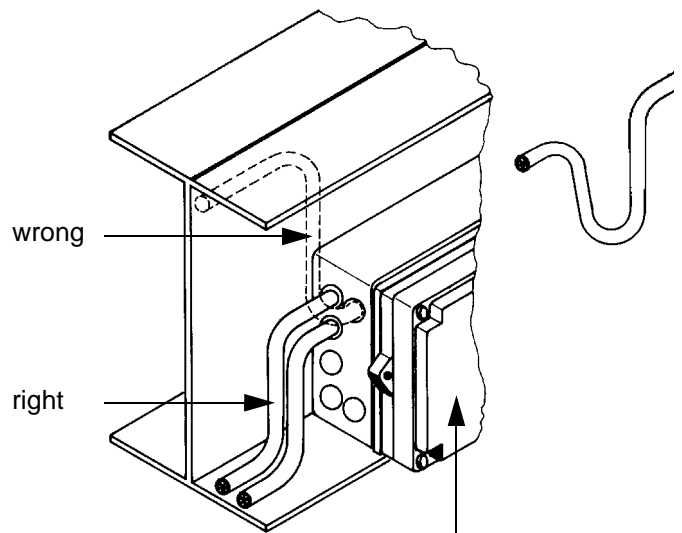

fuse inside of frame for mounting wherever possible

Fig. 20 Cable Passages; Water Trap

- Before a solenoid or sensor cable enters the ECU's housing, the compression gland must first be sleeved over the cable.
- Any slack remaining in the cable once the connections have been made can be gathered up in the way shown (↓ Fig. 21).

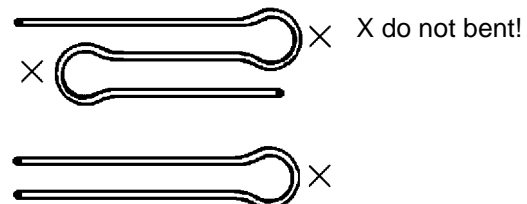
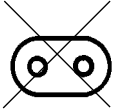

Fig. 21 Z-shaped Loop

! The bending radius of a cable must always be 9 to 10 times greater than the cable's diameter.

Seals are specifically designed for sensor, solenoid, and supply cables supplied by WABCO. In special applications, additional cable may be needed.

! Use only cable of the circular section type and the right diameters are used.



wrong since no seal possible

Fig. 22 Cables with permissible and not permitted External Diameter.

Sealing Range

PG 11 - sealing 6.0 - 11 mm

8.2.2 Base Plate Assignment (ECU Variant 446 055 065 0)

The assignment of the plug-in connections is as followed
↓ Fig. 23):

Connector X1

Diagnostic cable leading to the diagnostic socket on the housing.

Connector X2

Cables leading to remote control unit
(top left: terminal 31 / top right: Terminal 15 / bottom left: clock pulse line/ bottom right: data cable).

Connector X3

Power supply and C3 signalling line from ABS- or EBS-ECU.

Connector X4

Trailer battery connection for power supply of ECAS in stationary operation (top: battery switch / bottom left: positive wire / bottom right: ground wire) - ('pressure sensor for right RA' only on ECU variant 446 055 060 0).

Connector X5

Pressure sensor connector to determine bellows pressure (top: positive wire / bottom left: signalling line / bottom right: ground line - ↑ please refer to 8.1.2 pressure sensor)

Connector X6

Connector for a signal lamp to be installed on the trailer (24 volts 5 watt).

Connector X7

Connector for a levelling switch to control the 3rd driving level or the unloading level (connected to ground).

Connector X8

Top: output of ABS L-line to diagnostic socket (only ECU variant 446 055 065 0 - otherwise ground wire) / bottom: line from leveling switch for setting 2nd driving level (connected to ground).

Connector X9

Line lead from (push-bottom) switch of traction help in driver's cab (connected to ground ECU variant 446 055 060/070 0, connected to positive or ground on ECU variant 065/066).

Connector X10

Line leading to stop light switch to deactivate ECAS while brakes are being applied (connected to positive).

Connector X11

Connecting line leading to ECAS solenoid valve (or part of the ECAS solenoid valve) to control the leading axle; top left: ground connection / bottom right: control port of breather valve / bottom left: control port of supporting bellows valve on the left / bottom right: control port of supporting bellows valve on the right.

Connector X12

Connection from height sensor on front axle (also to the left-hand height sensor on the leading axle if separate right/left control is to be achieved via remote control unit - ↓ see Connector X13).

Terminal X13

Connection from right-hand height sensor on the leading axle for 2-point control of leading axle.

Connector X14

Connection of left-hand height sensor on the rear axle (WABCO recommends that this connector is always assigned - i.e. even if the system uses only one height sensor.)

Connector X15

Connector for a switch for automatically lowering the lifting axle.

Connector X16

Connector for the ECAS solenoid valve to control the front axle.

Connector X17

Connector for a solenoid valve which supplies the bellows pressure control ports of the load sensing valve with full suspension system air pressure in the event of the supporting bellows failing (e.g. bursting).

(Connector X18)

Connector of the lifting bellows with a separate solenoid valve (only for variant 446 055 060 0, otherwise no assignment)

Connector X19

Connector for the LOWER function of the lifting axle on the control portion for the lifting axle on the ECAS solenoid valve.

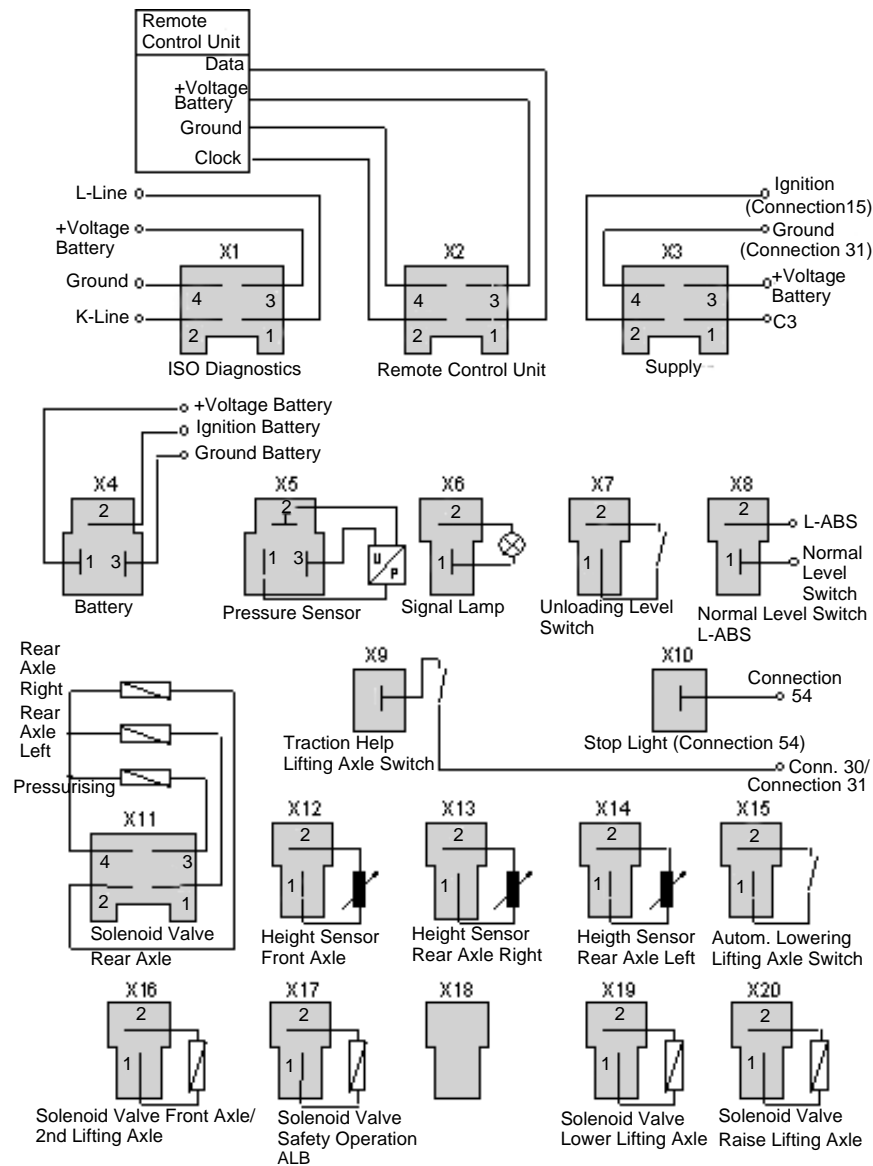

Fig. 23 Port Allocation (ECU Variant 446 055 065 0)

Connector X20

Connector for the RAISE function of the lifting axle on the control portion for the lifting axle on the ECAS solenoid valve.

Plug-in connections 12 - 20 all have two poles. The upper pin is always in the ground connection and is switched through for these connectors. This means, any missing ground contact may be obtained from a free plug-in connector. The lower pin is used as described above and must be switched to ground.

To prevent wrong connections, the cables in the ECU may be flagged in different colours. Another way to distinguish cable is found in ECUs which are supplied as kits.

Their cables may show flags in different colours on the outside, showing symbols for the components to be connected to them.

8.2.3 Power Supply and Diagnostic Assignment

Trailers fitted with VARIO C-ABS have the power for the ECAS-ECU variant 446 055 060 0, supplied via a supply module. It is in the housing of the ABS-ECU and has to be plugged in separately.

The circuit diagram for this supply module not only shows the supply but also the assignment for trailer battery operation.

The connections of an ABS VARIO C with ECAS-ECU variant 446 055 065 0 in which the supply module is no longer required (↓ see annex).

In modern trailer version which have VCS installed (VARIO COMPACT ABS), the ECAS receives its power supply from the diagnostic connection of the ABS-ECU. The C3 signal is provided to the ECAS-ECU via a separate C3-line.

To connect it, all that needs to be done is to push the plug into the connector.









Connectors X1 and X3 on the ECAS-ECU are of particular importance. They are used for the power supply and the diagnostic assignment.

The ECAS system on trailers with EBS receives its power supply in a similar manner to an ECAS system on trailers with VCS. The ECAS-supply cable is connected to the DIA/ECAS/ISS output port on the EBS-ECU. The C3 signal is transmitted to the ECAS-ECU via the K-line.

Power Supply in the ECAS (ECU Variant 066)

In the initial versions, Connector X3 top right and Connector X3 bottom left were bridged. As a rule, this is no longer necessary. If in doubt, establishing a bridge should not cause any damage because this bridge is already in place internally. The lower pins in Connector X3 are dispensable.

Table 1: Assignment for ABS Vario C, VCS and EBS applying to the Different Systems

Connector	ABS Vario C (ECU Variant 060)		VCS (ECU Variant 065)		EBS (ECU Variant 066)	
	Assignment	Line Leading	Assignment	Line Leading	Assignment	Line Leading
 X1			Pin 31	To Diagnostic Socket Pin 7	Ground	To Diagnostic Socket Pin 7
 X1			Pin 30	To Diagnostic Socket Pin 1		
 X1	K-Line	To Diagnostic Socket Pin 3	K-Line	To Diagnostic Socket Pin 3	K-Line	From EBS Diagnostic Plug to Diagnostic Socket Pin 3
 X1	L-Line	To Diagnostic Socket Pin 6	L-Line	To Diagnostic Socket Pin 6	L-Line	To Diagnostic Socket Pin 6
 X3	Pin 31	From Supply Module Connection 'ECAS' Pin 3	Pin 31	From ABS Diagnostics Pin 4	Ground	From EBS Diagnostics Plug to Pin 3
 X3	Pin 30	From Supply Module Connection 'ECAS' Pin 1	Pin 30	From ABS Diagnostics Pin 3	+24 V	From EBS Diagnostics Plug to Pin 4
 X3	Pin 15	From Supply Module Connection 'ECAS' Pin 2	ABS-L-Line	From ABS Diagnostics Pin 2		
 X3	C3-Signal	From ABS-ECU Supply Plug Pin 8	C3-Signal	From ABS Diagnostics Pin 5 and to Diagnostics Socket Pin 2		
 X8			ABS-L-Line	To Diagnostic Socket Pin 5		

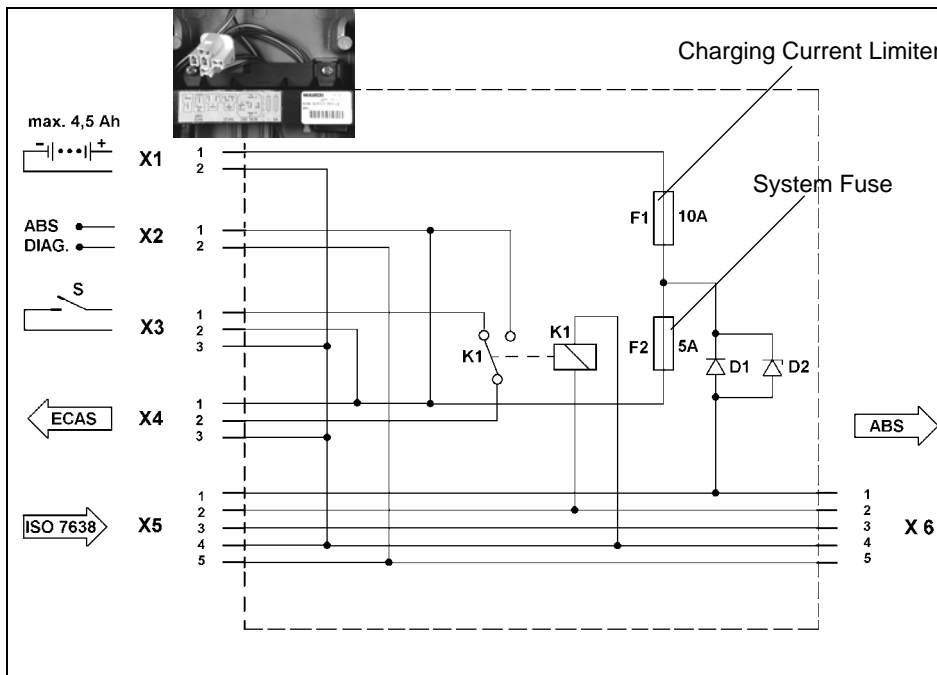

Fig. 24 Circuit Diagram of Supply Module for ECAS-ECU Variant 060 with ABS-Vario C (no current)

- X1: Battery Supply
 - 1 = + 24 V (Terminal 30)
 - 2 = Ground (Terminal 31)
- X2: ABS Diagn. to Diagnostic Socket
 - 1 = + 24 V (Terminal 30)
 - 2 = + Signal Lamp Line
- X3: Battery Switch
 - 1 = Ignition (Terminal 15)
 - 2 = + 24 V (Terminal 30)
 - 3 = Ground (Terminal 31)
- X4: ECAS Power Supply
 - 1 = + 24 V (Terminal 30)
 - 2 = Ignition (Terminal 15)
 - 3 = Ground (Terminal 31)
- X5: ISO 7638 = X6: ABS Power Supply
 - 1 = + 24 V - ABS Solenoid Valve (Terminal 30)
 - 2 = Ignition - ABS-ECU (Terminal 15)
 - 3 = Ground Warning Lamp
 - 4 = Ground ABS Solenoid Valve + ECU (Terminal 31)
 - 5 = + Signal Lamp Line

8.2.4 Battery Operation

ECAS can also be operated while the vehicle is stationary. A storage battery (24 V, 7.2 Ah) is needed on the trailer. This battery could, for instance, consist of two 12 volt motor cycle batteries connected in series.

- If battery operation is intended, a sufficient air supply must be ensured.

! For independently operating the trailer, a recommended air volume of at least 40 litres per axle is recommended.

If Pin 30 ISO7638 of the vehicle is active with cut off ignition its past on to the battery by the trailer modulator. The charge current is limited to 3.5 A.

The EBS electronic control unit takes over monitoring via this connection when the ignition is switched on (e.g. the EBS electronic control unit is operating).

The output is switched on only under certain conditions. A connected battery is only charged if the supply voltage measured by the trailer EBS modulator is greater than 24 volts and no EBS/ABS braking is taking place. The charging process is switched off if the supply voltage falls below 23 volts. The charge current is limited to 3.5 A.

The ECU Variant 446 055 060/070 0 can permit a battery mode due to the supply module.

- To activate ECAS with the battery, a battery switch

has to be connected to the supply module.

- After battery operation that switch should be turned off to make sure that the storage battery is not discharged completely.

A more convenient solution to protect the battery against complete discharge is to use a time switch relay. Battery switch Connector X3 with ground connection (Pin 3) is designed for connecting an electrical time switch relay. In addition, a 10 amps fuse is provided as discharge protection.

ECAS-ECU Variant 446 055 065/066 0 can be connected to the storage battery via plug-in Connector X4 on the base plate of the ECU.

The storage battery is charged via supply module by motor vehicle's generator. To ensure that the charging current is not excessive, the storage battery's permissible capacity is limited to a maximum of 7.2 A/h. Any capacities beyond that require a diode to be used which prevents charging of the storage battery. This capacity, depending on the number of control cycles to be performed, permits the system to be operated for several hours.

ECAS can also be operated via the storage battery of another aggregate.

! Ensure (e.g. by using a diode) that no charging current leading to that aggregate goes through the supply module.

8.3 ECAS Solenoid Valve

For the purposes of controlling the system, the ECAS solenoid valve is the interface between the electronic output signals from the electronic control unit and the pneumatic actuating signals for the air suspension bellows. Each one ECAS solenoid valve is installed per axle respectively axle aggregate.

In the ECAS solenoid valve several individual solenoid valves are combined in a block. Each of these solenoid valves is a combination of an individual solenoid with one or two pneumatic valves with one or two control slides.

The corresponding ECAS solenoid valve is plugged into Connectors X11, X16, X19 or X20 ↑ 8.2.2 Pin Assignment (ECU variant 446 055 065 0) on the ECU's base plate (↑ Fig. 23) according to its intended function.

The electrical control signal for activation of the individual solenoids is sent from the electronic control unit by means of the electrical plugs on the individual solenoids or individual solenoid valve blocks. This individual solenoid effects opening/closing of the respective valves respectively moving of the respective slides.

This control represents an indirect control since the valve solenoids are opening a valve seat (1).

Via this open valve seat the supply pressure or air supply flows onto the control pistons (3), (9) or (10) or onto the control slides and pressurizes them so that they move into the position desired.

Depending on the Solenoid Control of Air Valves, there are two Types of Valves:

8.3.1 Spring-returned Valve

The spring-returned valve is a 3/2- or 2/2-way valve, or directional control valve, inside the ECAS solenoid valve. It is mainly used to control the supporting bellows at the front axle or the rear axle which is always on the ground. The valve can be either a sliding valve or a seat valve.

The 3/2 directional control valve, if this is a seat valve as shown in the cross-sectional drawing (↓ Fig. 25), operates as follows:

1. When solenoid (41) is energised, valve seat (1) opens.
2. It allows pneumatic control pressure from duct (4) to flow through duct (2) until it acts on the top of control piston (3).
3. The piston (3) now opens valve seat (6) against the force of a return spring.

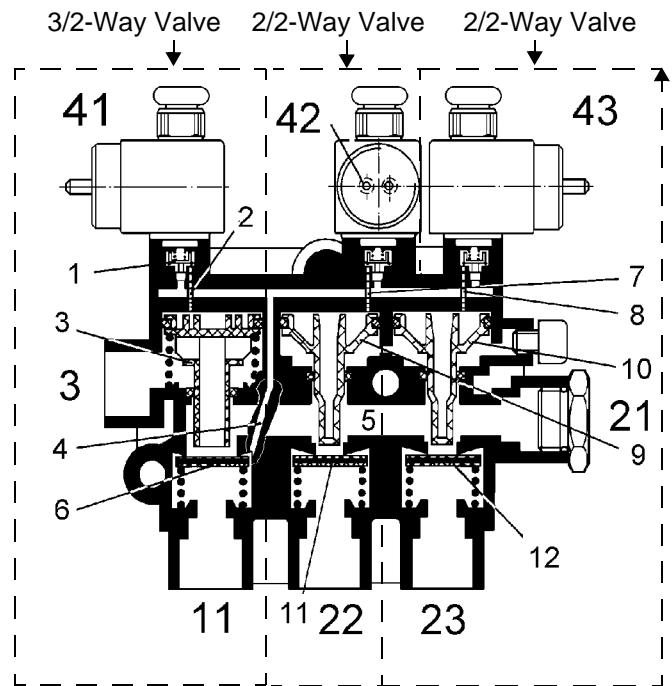

Fig. 25 Cross-Section of an ECAS Solenoid Valve with Spring-Returned Seat Valves for the Leading Axle (Individual Solenoids)

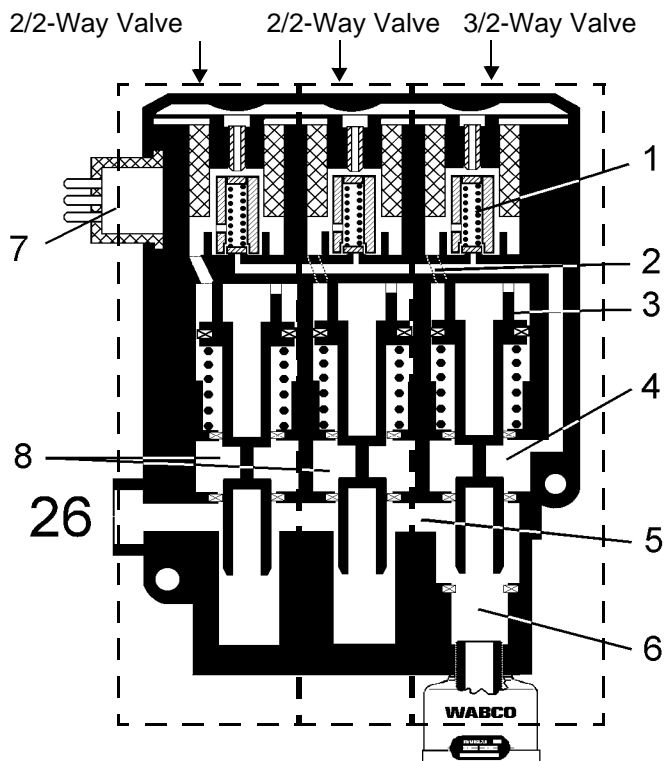

Fig. 26 Cross-Section of an ECAS Solenoid Valve with Spring-Returned Sliding Valves for the Leading Axle or the Main Axle Portion (Solenoid Block)

Thus permits duct (5) and any downstream consumers to be pressurised.

When the solenoid is no longer energized:

4. Valve seat (1) is closed and the top of the control piston (3) is evacuated.
5. The valve spring closes valve seat (6) and, with the help of the piston return spring, returns the control piston (3) to its original position.
6. Through control piston (3), which is hollow, duct (5) and any downstream consumers are evacuated.

Operation of the 2/2-way valves follows the same principle.

In ECAS solenoid valves from more recent generations, the seat valves are progressively being replaced by sliding valves. The spring-returned sliding valve (↑ Fig. 26) works in a similar fashion. The essential difference is that the seat valves have been replaced by slides which, however, are also controlled by a return spring.

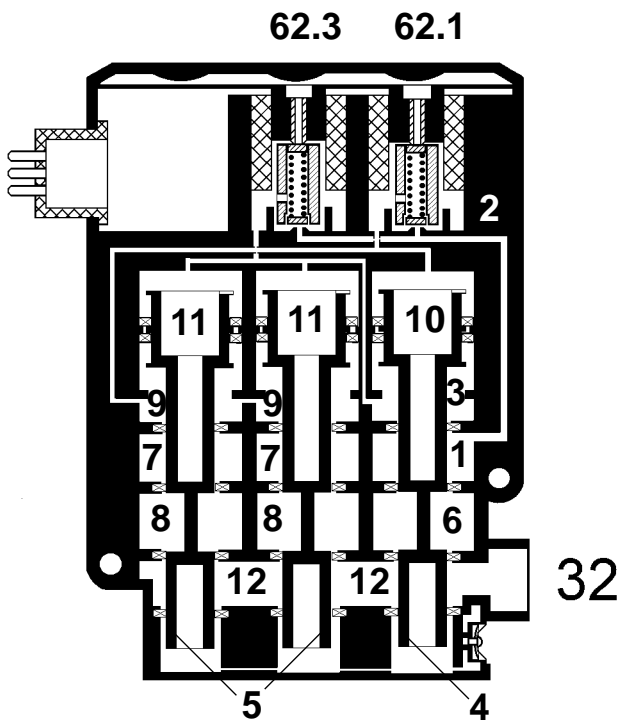

Fig. 27 Cross-Section of an ECAS Solenoid Valve with Pulse-Controlled Sliding Valves for the Lifting Axle Portion in the 'Pressure Hold' Position

8.3.2 Pulse-Controlled Sliding Valve

The pulse-controlled sliding valve is a 3/3-way valve within the ECAS solenoid valve. It is mainly used to control the lifting axle bellows together with the supporting bellows of the lifting axle. Pulse-controlled valves can be used for automatically controlling lifting axle. Usually the group of solenoid valve for controlling the lifting bellows are flanged onto the group of solenoid valves for control-

ling the leading axle.

The 3/3-way valves (↑ Fig. 27) operate as follows:

1. In annular chamber (1), the supply pressure acts on control solenoid (62.3 'raise' lifting axle) and (62.1 'lower' lifting axle) via duct (2).
2. For raising, control solenoid (62.3) receives a current pulse - hence pulse-controlled - and opens its valve seat.
3. Through a system of ducts, annular chamber (3) at control piston (4) is pressurised.
4. Thus forces the control piston upwards and annular chamber (1) is connected with annular chamber (6) at whose outlet the lifting bellows are connected.
5. This causes the lifting bellows to be filled.
6. At the same time, pressure acts on the top of the two control piston (5) as the pressure in chambers (11) is increased, and the control pistons are forced downwards.
7. Annular chambers (8) are connected to the supporting bellows of the lifting axle. They are connected to duct (12) and evacuated through vent (32).
8. These processes cause the lifting axle to be raised.

When there is no longer any current pulse on the solenoid, chambers (3) and (11) are evacuated through the solenoid vent.

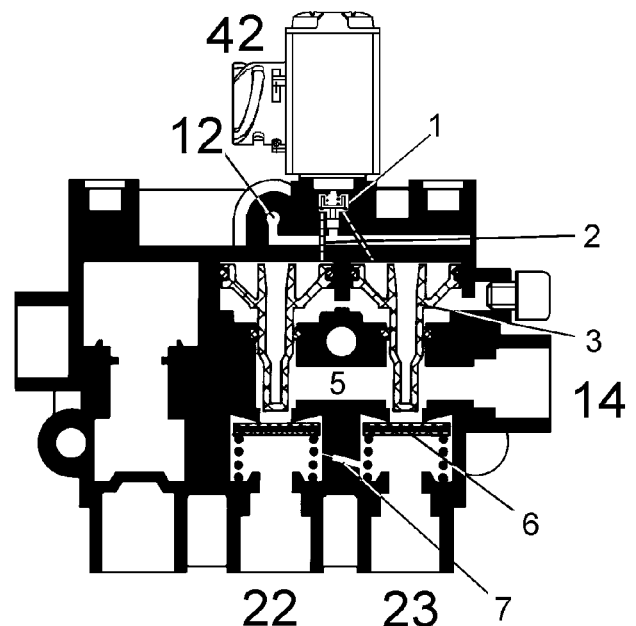

Fig. 28 Cross-Section of an ECAS Solenoid Valve with Spring-Returned Seat Valves for the Front Axle (Steering Axle)

The position of the slides in the ECAS solenoid valve does not change until changed by another control pulse.

1. To lower the lifting axle, solenoid (62.1) receives a current pulse and opens its valve seat.
2. Through a system of ducts, annular chamber (10) at control piston (4) is pressurised.
3. This pushes the piston downwards and annular

chamber (6) whose outlet is connected to the lifting bellows is connected with duct (12) .

4. This causes the pressure in the lifting bellows to be reduced.
5. At the same time, the annular chamber (7), with the pressure of the supporting bellows is connected to annular chamber (8), with the supporting bellows connected to the lifting axle.
6. The pressure in the supporting bellows for the leading axle and the lifting axle is balanced.
7. These processes cause the lifting axle to be lowered.
8. When there is no longer any current pulse on the solenoid, chambers (9) and (10) are evacuated through the solenoid vent.

The valve position (↑ Fig. 27) represent a special case and causes the pressure in all bellows to be held. This will occur, for instance, when the pressure in the supporting bellows for the leading axle and the lifting axle vary while traction help is active. This means the pressure in the supporting bellows of the leading axle is at its maximum and the pressure in the supporting bellows of the lifting axle is lower. This condition is achieved by control solenoids (62.1) and (62.3) being continuously switched on simultaneously.

8.3.3 Difference between 3/2-, 2/2- and 3/3-Way Valves

3/2 Directional Control Valve

(i.e. 3 pneumatic connections: supply, consumer and vent - and two switching positions - in this case: ON or OFF depending on the solenoids energized)

Via this valve, any downstream consumer are supplied with the supply pressure p_1 of the air suspension system, or evacuated when the switching position is ON.

In the OFF switching position, the downstream consumers are connected to atmosphere.

One typical application for this type is to control the increase or decrease in pressure at the rear axle valve or at the leading axle valve.

2/2 Directional Control Valve

(i.e. 2 pneumatic connections: supply and consumer - and two switching positions - in this case: ON and OFF depending on the solenoids energized)

Via this valve, any downstream consumer are supplied with the supply pressure p_1 of the air suspension system when the switching position is ON.

In the OFF switching position, the downstream consumers are shut off, i.e. the pressure is being held.

One typical application for this type is to be established or to shut off the passage for the compressed air to the sup-

porting bellows of the axles which stay on the ground, i.e. in the front axle valve, rear axle valve and the rear axle block for the rear axle/lifting axle valve. The number and allocation of the 2/2-way valves in the ECAS system exactly corresponds to the number and allocation of the height sensor used.

- If ECAS controls the left and right sides of the axle individually (2-point control of the axle) each individual magnet actuates one 2/2-way valve (↑ Fig. 25).
- If, on the other hand, ECAS controls the axle as one unit (1-point controlled axle) one individual solenoid actuates two 2/2-way valves (↑ Fig. 28).

In the latter case, the consumer output ports leading to the supporting bellows are interconnected with a transverse throttle to balance the pressure.

3/3 Directional Control Valve

(i.e. 3 pneumatic connections: supply, consumer and vent - and three switching positions - in this case: TOP, CENTRE and DOWN depending on the position of the control slide in the valve)

- In the TOP switching position, a connection is established between supply (1, looking at the right-hand one) and consumer (6). This causes the pressure to be increased.
- In the CENTRE switching position, the downstream ports are shut off. This applies to holding the pressure.
- In the DOWN position, a connection is established between the consumer and atmosphere. The pressure is reduced.

One typical application for these valves:

Controlling the supporting bellows and the lifting bellows on the lifting axle within the lifting axle block of the rear axle/lifting axle valve is to be operated automatically by the system.

Due to the individual solenoid valves partial load pressures cannot be generated at the valve seats.

The following three positions are achieved by combination of the functions of the individual solenoids:

- Pressure build-up
- Hold pressure
- Reduce pressure

Any changes in the balanced condition of the air suspension system are picked up by the height sensor only, interpreted by the ECU.

The required commands are transmitted to the ECAS solenoids valve.

The ECAS solenoid valve is located on the frame – preferably on a frame cross-member – above the axle to be controlled, or above the axle assembly to be controlled.

! The pipes and cables leading off the bellows should be symmetrical, i.e. identical in length and in diameter. The proper allocation of air and electrical connections follows the numbering system.

8.3.4 Differentiation of the ECAS Solenoids Valves depending on their Application

Front Axle Valve (FA Valve)

The FA valve is located near the front axle and controls the supporting bellows for the front axle. The FA valve usually has only one 2/2-way valve for the front axle (steering axle) - 1-point control for the axle.

The process of increasing and decreasing the pressure is taken over by the 3/2-way valve of the rear axle valve.

Rear Axle Valve (RA Valve)

The RA valve is the core of an ECAS system with no automatic lifting axle facilities. It is located near the rear axle and controls the supporting bellows of the rear axle. An additional air output port can be used to pressurised or evacuated any downstream consumers, e.g. a FA valve on drawbar trailers. The RA valve usually has a 3/2-way valve to increase or decrease the pressure.

Depending on the type of ECAS used, the RA valve for controlling the supporting bellows varies as well:

- 1/2-way valve if the axle has a 2-point control.
- 2/2-way valve if the axle has two 2-point control.

Rear Axle/Lifting Axle Valve (RA/LA Valve)

The RA/LA valve is the core valve of a system with automatic lifting axle control. The valve consists of a rear axle block and a lifting axle block. Its functions is similar to that of the rear axle valve.

It is located near the rear axle and controls not only the supporting bellows of the rear axle but also the lifting bellows and the supporting bellows of the lifting axle.

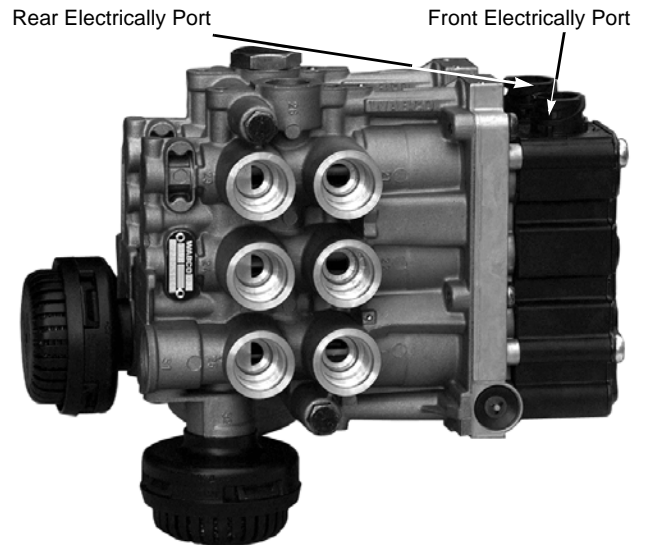

Fig. 29 Sliding Valve (Rear Axle and Lifting Axle Control)
472 905 114 0

An additional air output port can be used to pressurise or evacuate any downstream consumers, e.g. a FA valve on drawbar trailers.

The RA/LA valve usually has a 3/3-way valve in its rear axle block for increasing or decreasing the pressure.

Depending on the control used in the ECAS it consists of a control for the supporting of the rear-axle bellows:

- 3/2-way valve if the axle has a 1-point control.
- 2/2-way valve if the axle has a 2-point control.

There are three 3/3-way valves in the block of lifting axle valves which are actuated by two valve solenoids. They are responsible for controlling the lifting bellows and the supporting bellows of the 1st lifting axle.

! Clear allocations can only be made by referring to a circuit diagram (↓ 12. Annex).

Whilst the assignment of the electrical connections is not standardised, the following guideline applies to the assignment of air connections, or ports:

Port 1

Only on RA/LA valves: Supply from reservoir for downstream consumers.

Port 11

Only FA valves and on RA valves: Supply from reservoir for downstream consumers.

Port 12

Only FA valves and on RA valves: Actuating pressure from reservoir to actuate the control element in the ECAS solenoid valve.

Port 13

Not relevant for operation.

Port 14

Only on FA valves: Supply port from RA valve.

Port 21

- On dedicated RA valves: Output for Port 14 of FA valve.
- Only on RA/LA valves: Output for (left-hand) supporting bellows of the axle(s) which is (are) on the ground.

Port 22

Output for (right-hand) supporting bellows of the axle(s) which is (are) on the ground.

Port 23

- On dedicated FA or RA valves: Output for (left-hand) supporting bellows of the axle(s) which is (are) on the ground.
- Only on RA/LA valves: Output for (left-hand) supporting bellows of the lifting axle for fully automatic lifting axle operation.

Port 24

Output for (right-hand) supporting bellows of the lifting axle for fully automatic lifting axle operation.

Port 25

Output for lifting bellows on the lifting axle for fully automatic lifting axle operation.

Port 26

- Only on RA/LA valves: Possible output for Port 14 of FA valve.
- On buses also output for supporting bellows on the front axle for the 'kneeling' function.

Port 27

- Not relevant for operations on trailers.
- On buses also output for supporting bellows on the front axle for the 'kneeling' function.

Port 3

Only on RA valves: Evacuation for downstream consumers.

Port 31

Only on RA/LA valves: Evacuation for downstream consumers in rear axle block.

Port 32

Only on RA/LA valves: Evacuation for downstream consumers in lifting axle block.

At present, ECAS solenoid valves with DIN bayonet connectors are being used. The solenoids are no longer exposed but are located inside a block of solenoid valves.

- The bayonet connector of the FA valve contains two pins which are plugged into Connector X16 on the ECU.
- The bayonet connector of the RA valve contains four pins which are plugged into Connector X11 on the ECU.

The RA/LA valve has two DIN bayonet connectors.

- The DIN bayonet Connector for the rear axle portion is also plugged into connector X11 on the ECU.
- The DIN bayonet Connector for the lifting axle portion is also plugged into Connector X19 and X20 on the ECU.

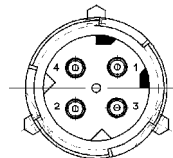

Fig. 30 RA Valve with DIN Bayonet 472 900 055 0

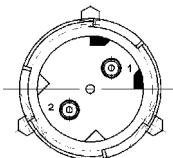

Fig. 31 FA Valve with DIN Bayonet 472 900 058 0

Table 2: Solenoid Valves

Configuration	Solenoid Part Number		Remark
	ECAS II	ECAS III	
RA 2-Point Control	472 900 053 0	472 880 001 0	3 Solenoid, VOSS Port
FA	472 900 054 0	472 880 020 0	1 Solenoid, 3 Pins, VOSS, not compatible
FA	472 900 058 0	472 880 021 0	1 Solenoid, 2 Pins, VOSS, not compatible
RA 1-Point Control	472 900 055 0	472 880 030 0	2 Solenoids, VOSS
RA + FA	472 900 057 0	472 880 050 0	4 Solenoids (3+1), 2 Electrical Ports, VOSS
RA + LA	472 905 111 0		5 Solenoids (3+2), 2 Electrical Ports, VOSS
RA + SA	472 905 114 0		4 Solenoids (2+2), 2 Electrical Ports, VOSS

8.4 Remote Control Unit 446 056 116/117 0

With the Remote Control Unit the Driver can:

- Change the vehicle's reference level,
- Adjust the position of the lifting axle,
- Switch on traction help,
- Preselect the desired driving level.

The vehicle's level can be adjusted only while the vehicle is either stationary or moving at a speed that is slower than a limiting speed v_{OPER} .

- This limiting speed must be set on the ECU as part of the procedure for setting the parameters.

The remote control unit is preferably mounted into a housing.

Build contact to ECU:

- Plug the coiled cable into the socket on the vehicle.

Various control units are available depending on the type of system used.

8.4.1 Functions of ECU 446 056 117 0

- Lowering and raising of the superstructure simultaneously above all axles, separately above the front or rear axle or axle assembly, and, if the system is designed for this, separately on the axle's right-hand and left-hand side.
- Raising and lowering the lifting axle and thereby switching off or on any fully automatic lifting axle operation, and reducing or increasing the load on the trailing axle.
- Activating the traction help facility.
- Preselection of a driving level from up to three possible driving levels and adjustment of the current - i.e. preselected - driving level.

- Storing up to two preference (i.e. memory) levels and adjusting these levels by briefly pushing the appropriate button.
- Setting the vehicle to STAND-BY operation where the power for ECAS is supplied from the trailer's own storage batteries.

Systems with less comprehensive configurations (e.g. semi-trailers because they have no front axle) show no reaction if a button is pushed which the system is unable to identify (e.g. selecting the front axle on the semi-trailer).

Fig. 32 shows the most important parts of ECU 446 056 117 0.

The layout of the remote control unit shows three lamp in its upper row ILF, ILR and ILL. They inform the user which axle has been preselected for the adjustment to be made.

Below these are three preselect buttons PSF, PSR and PSL in a row. Each of these buttons is located below the appropriate lamp.

- Push the preselect button.

The corresponding lamp will come on, indicating to the user that the preselected axle can be actuated.

- Pushing a preselect button again.

It makes the appropriate indication lamp go off again indicating to the user that the input mode has been aborted from the remote control unit.

 No further change can be achieved via the remote control unit.

Reference level for the whole vehicle is to be changed:

- Keep PSF- and PSR-button depressed.



Fig. 32 ECU 446 056 117 0 and its Components

Both corresponding check lamps must be on to indicate that the system is ready for actuation.

! Usually any input using the remote control unit begins by preselecting the desired axle(s) and ends by cancelling the input mode.

Raising and Lowering of the Superstructure

- Keep the RAISE or LOWER button depressed. The ECU is given a changed reference level for the superstructure above the preselected axles. The superstructure changes its height above the axle without delay as long as the button is being hold.
- Release the RAISE or LOWER button. The change in the reference value ends. The last reference level which applied when the button was released is assumed to be the new reference level.

Raising and Lowering the Lifting Axle

- Briefly pushing the RAISE or LOWER button after preselecting PSL button. The lifting axle is raised or lowered or the weight resting in the trailer's axle is increased or decreased. Raising, i.e. increasing the weight, is only possible provided the defined permissible maximum pressure in the leading axle's supporting bellows is not exceeded.

Lowering the lifting axle, or increasing the weight on the trailing axle, causes any automatic operation of the lift-

ing/trailing axle for which the parameters may have been set to be switched off.

Switching off Automatic Lifting/Trailing Axle Operation

The automatic lifting/trailing axle operation can be switched off, if at least one lifting/trailing axle has been automatically raised/relieved due to a light load.

- Push LOWER button. Switching off automatic lifting axle operation means that the lifting axle(s) which was (were) raised automatically before are lowered, or the load on any relieved trailing axle(s) will be increased.

When automatic lifting/trailing axle operation is switched off, the ignition lamp on the trailer will indicate so on ECU Variant 446 055 060 0.

Switching on Automatic Lifting/Trailing Axle Operation

- Push PSL button and after that RAISE button. If the parameters have been set for manual lifting axle operation, the raising or lowering function is performed as described above.

Traction Help

- Push PSL button and after that M 1 button. Traction help facility is activated.

 This only applies if the parameters have been set for automatic lifting/trailing axle operation.

- Push STOP button to abort traction help.

 The STOP button also aborts traction help if activated with the button in the motor vehicle.

Driving Levels

If the parameters have been set accordingly, the remote control unit can be used to activate the driving levels I, II and III. It is sufficient to preselect one existing vehicle axle.

- For driving level I push the M 1 button and DL button simultaneously.
- For driving level II push the M 2 button and DL button simultaneously.
- For Driving Level III push the DL button and RAISE button simultaneously.

This selects a driving level which assumed to be the current driving level until another driving level is selected.

Selecting the current driving level:

- Briefly push DL button.

Memory Levels

If a certain level is to be addressed frequently when the vehicle is being loaded or unloaded.

That level can be stored or adjusted by pushing a button at any time.

- Push STOP button and M 1 or M 2 button simultaneously.

An existing reference level can be stored as the memory (or 'preferential') level.

The stored values are not lost when the ignition is switched off. They apply to the whole of the vehicle, i.e. when retrieving it, it is sufficient to simply preselect one axle.

- Push corresponding button M 1 or M 2.

The vehicle's superstructure is immediately brought to the level stored.

Stop

- Push STOP button.

All levelling control processes are stopped immediately, the present level is recognised as the reference level.



This function primarily permits the operator to cancel any automatic changes in the vehicle's level (memory, driving level) if he considers that the continuance of that control process would be hazardous.

- Switch off ignition by hold down STOP button.

The vehicle is put into a Stand-By mode.

Via an additional battery switch on the trailer, ECAS can now receive its power supply from sources outside the motor vehicle.

Dependency on Speed

The "Raising and lowering of superstructure" and "Memory level" functions can be used only when the vehicle is either stationary or has not exceeded a preselected speed v_{OPER} . Any control process which was started below that speed will be completed.

Manual lifting/trailing axle control from the remote control unit is accepted by the ECU only if the vehicle's speed has not exceeded another predefined speed $v_{LA-LIMIT}$.

Pressing several Buttons simultaneously

If several buttons are pressed simultaneously and these do not represent a plausible combination, no command will be accepted. The STOP function is executed.

Disconnecting the Remote Control Unit

- Disconnect the remote control unit.

The STOP function is executed immediately.

With ECAS software from Version 9.1.1 D upwards, the change of any reference value continues even when the remote control unit is disconnected.

Using several Remote Control Units

In addition to the remote control unit on the trailer, Trailer ECAS permits a second remote control unit to be used, e.g. in the driver's cab.

To ensure that only one of these remote control units communicates with the ECU, the DATA line leading to the ECU must have a selection switch fitted for selecting one of these two remote control units. This also applies if more than two remote control units are used.



Do not connect two remote control units to the ECU in parallel. This is not permitted and will result in operational problems.

Priority

The remote control unit has a high priority within the system. If the Unloading Level function has been activated and a raise/lower command is given via the remote control unit, the command from the remote control unit will be executed.

If the RAISE/LOWER function has failed, the vehicle's superstructure can be taken to a reasonable level so the vehicle can be driven to the workshop.

- ECAS needs to be aware of the existence of a remote control unit. For this reason, the remote control unit must be connected to the ECU before the system can be put into operation.

ECAS using no Remote Control Unit

When the system is not intended to use no remote control unit, the following must be taken into account:

- The connections for the DATA and CLOCK lines for the remote control unit on the ECU (plug-in connection X2, bottom left and bottom right ↑ 8.2.2 Pin Assignment (ECU variant 446 055 065 0)) are permanently connected to each other ('bridged')

This allows the ECU to recognise that the system will be used without remote control unit and to address Driving Level I immediately after the ignition has been switched on.

If this plug-in connection is not bridged, Driving Level I will not be addressed until the speed for which the parameter has been set for returning to the driving level is exceeded.

8.5 Control Box



With the control box only Driving Level I can be selected, but not Driving Level II/III or Unloading Level. Control boxes have no memory button.

Control boxes have an extra port for a warning lamp. If the control box is connected as shown in plan 841 801 828 0 (combine VCS) or 841 801 829 0 (combine EBS) the integrated warning lamp has the same function as the external signal lamp.

Warning Light:

OFF	Vehicle has no failure in driving level
FLASHING	Failure in the system
ON	Vehicle has failure in driving level

Table 3: Control Box

Control Box Part Number	Description	Connecting Cable Part Number
446 156 010 0 	Raising/Lowering	449 637 050 0
446 156 011 0 	Raising/Lowering Lifting Axle Function	449 637 050 0
446 156 012 0 	Raising/Lowering for Drawbar Trailer	449 637 050 0

8.6 Battery Box

446 156 090 0	Battery Box without Batteries
446 156 094 0	Battery Box with 2x Panasonic lead Gel Accumulators LC-R127R2PG
449 517 060 0	Connecting Cable

8.7 Pneumatic Components and Installation Instructions

Like conventional air suspension systems, electronic air suspension systems include pneumatic components such as:

- Charging Valve
- Air Reservoir
- Plastic Piping,
- Screw-In Union.

Charging Valve

As in any air suspension system, the circuit for ancillary consumers is secured against the service braking circuit with a charging valve with no return flow of 6.0 bar (e.g. 434 100 125 0).

Air Reservoirs

The size of the air reservoirs for the air suspension system depends on the number of axles and on the systems requirements:

- For vehicles with no lifting axles, 60 to 80 litres are sufficient.
- For vehicles with lifting axles, 80 to 120 litres should be selected.

This provides sufficient reserves for the control process in loading ramp operation and for frequent lifting axle operation without any additional compressed air being provided from the motor vehicle. In this respect, ECAS is no different from other air suspension systems.

Plastic Piping

Regarding plastic pipes, ECAS achieves considerable savings compared to other systems which offer the same scope of function. On a vehicle with lifting axle control and an air suspension valve with height limiting facility, this will be more than 30 metres.

Because of the valve's large nominal width, the nominal width of the plastic pipes between the solenoid valve and the bellows is between 10 and 12 mm.

👉 12 mm is recommended unless the axle manufacturer or WABCO's diagrams require otherwise. The supply line's nominal width should never be less than 12 mm.

⚠️ To ensure that the lifting axle is not lowered or raised too rapidly and to prevent damage to the tyre it is recommended:

👉 The nominal width of the plastic pipes to the lifting bellows should be 8 mm.

To protect the lifting bellows against excessive pressures, and against creasing, WABCO has included the option of using pressure limiting valves and charging valves in the diagram. The instructions of the lifting bellows' manufacturers must be followed.

Screw-In Union

Most vehicle manufacturers use plug screws which are available from WABCO under the name of Anoflex. ECAS also achieves savings regarding screw-in connections. No such screw-in work is required at the rotary slide valve or the air suspension valve for the remote control unit or the height sensor. Even the expenditures for vehicle owners are reduced significantly when they use ECAS. Surveys among vehicle manufacturers fitting ECAS in series production have shown that installation times were reduced in comparison to conventional systems.

Test Connections

For service purposes, test connections are essential for quickly locating any defects.

In the event of total system failure it should be permitted to lower or raise the laden or unladen vehicle.

- At least two test connections for the service brake and the supporting bellows should be accessible externally if 1-point control is in place.

This allows the driver to lower the vehicle from outside (pushing the test connection), or to raise it (Connecting the two ports by means of the test hose and pressurising via the service brake system).

After removing the test hose, the pressure is looked inside the air suspension system because when there is no electrical current on the ECAS system it closes all ports.

Only a normal leakage will then cause the superstructure to be lowered again over time.

While checking the normal level, usually the vehicle can be driven across a short distance to the nearest workshop for repair.

Choosing Suitable Sites

When choosing suitable sites for the individual components, there are no definite rules other than those defined for the fitting position (↓ 12. Annex - outline drawings). However, accessibility for servicing is important. Information on the installation of the individual components:

Electronic (ECU)

This is located on a cross member or side member of the vehicle where it is not exposed to splash water or loose chippings.

- It must be installed vertically with the breather holes pointing downwards. Please note where the word TOP is shown on the housing.

⚠️ If installed horizontal, no warranty will be accepted.



Fig. 33 ECU with Test Connections

8. ECAS Components

On this tank semi-trailer, the ECU is easily accessible and located in an external box with all test and emergency filling connections.

Remote Control Unit

Its location varies with the type of system used, and the type of vehicle.

- It should, however, be connected externally in an easily accessible location which is not exposed to any splash water, and provided with a protective cover.
 - On tankers and vehicles carrying chemicals, the boxes at the side are often used for this purposes.
 - Tipper vehicles have a control unit interface at the side.
- Sitting in a protective box wherever possible.

This also offers space for additional switches or a storage battery for the power supply when the semi-trailer is detached from its tractor.

The HEDI-GmbH company offers subassemblies for the remote control unit. In addition, an accessory kit is available for housing two 12 volt storage batteries. For further information please contact:

The HEDI-GmbH Company, D-87725 Babenhausen



Fig. 34 Protective Box for Remote Control Unit

Optionally, the remote control unit can of course be installed on the motor vehicle. For this purpose, two 7-pole or 15-pole plugs are required. The towed vehicle can then be controlled completely from the front, even when moving at slow speed.

Solenoid Valve

- The solenoid needs good accessibility for servicing.
- Detach the incoming air lines if necessary.

The lifting axles block consists of two valve units screwed together.

- The part containing the pneumatic ports is the 'front'.

- Thus the 'rear' would be the valve portion facing the frame.

Coloured flags showing the valve and the words 'vorn/hinten' (= front/rear) thus makes it easier for the vehicle manufacturer to properly allocate the electrical connections.

The plastic pipes leading to the supporting bellows should be of equal length.

Pressure sensor

The pressure sensor is located near the supporting bellows.

👍 WABCO Recommendation:

- Connect the pressure sensor to a test valve (463 710 998 0) for pressure simulation.

This allows all of the vehicle's control processes to be simulated and checked, regardless of the load it carries, e.g. to check the behaviour of its lifting axle.

- Install the pressure sensor in an easily accessible location.

Any pressure peaks are suppressed by the ECU. A T-piece may be used for installation on the bellows.

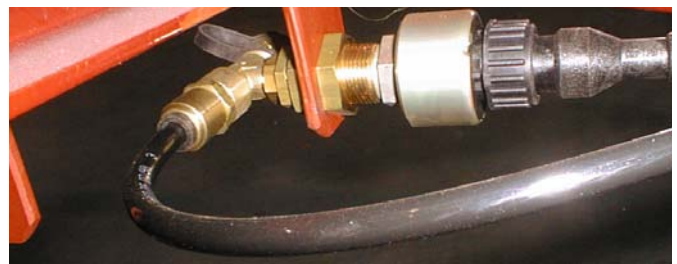

Fig. 35 Pressure Sensor with Test Connection

Height Sensor

The height sensor is installed in place of a conventional levelling valve. The master gauge is fully identical with that for the levelling valve, as is its installation site.

- It is important that for the whole of the control range the lever does not make contact in the upper or lower area.
- Please remember that when the vehicle is being driven, additional bounce occurs frequently, so sufficient room must be left between the lever and the limit stops.

- Wherever possible, a location should be chosen where the height sensor is not exposed to any chip-pings or splash water from the road.

Systems using two height sensors:

- Fit the sensors on the rear axle having them spaced as far apart as possible.
- All rotational axes should be in the same direction to avoid any transverse forces. The lever should not be bent at right angles.
- Unintentional shifts in position can be avoided by using a threaded rod to attach the lever to the axle.

The lever has three holes for length adjustment.

! The longer the lever, the greater the possible control range.

At the calibrated or main driving level, a lever position of 90° to the sensor is recommended to achieve the best possible resolution.

- This is easy to achieve by pushing the lever along the threaded rod at driving level.
- Then tightening it.



Fig. 36 Height Sensor

Electrical Feed Lines

- Any extra lengths in sensor or solenoid lines should be laid in the form of a Z.
- Shortening them should be avoided because this would mean that they would have to be crimped again. If this becomes necessary use Crimp Set 446 008 911 2.
- Cables which have to be attached to objects subject to constant rocking or vibration should be fastened using double cable binders 894 326 012 4.



Such rocking or vibration will eventually result in strain hardening and thus premature damage.

- Cable binders should only be tightened to the extent that cables are sufficiently held in place.

9. Commissioning and Diagnostics

Diagnostics

ECAS is an universal system. This means that after installation of all ECAS components, the system needs to be prepared for operation.

This commissioning procedure consists of:

1. Setting the parameters for the ECAS system.
2. Calibrating all sensors which are part of the ECAS system.

Setting Parameters

When setting the parameters, a set of parameters which defines all of the functions to be implemented and all limiting and control threshold values are entered in the ECU. When new, the ECU is aware of some parameters; however, this 'emergency set of parameters' only covers an absolute minimum of parameters.

The ECU's parameters must be set:

- For new systems,
- After replacing ECU.



This work must be done by trained staff.

These trained staff have a special numeric code allowing them access to the appropriate parts of the programmes of the diagnostic equipment.

Calibrating

When the parameters have been set, the sensors of the ECAS system have to be calibrated. Therefore the driving level is defined as normal level for the ECU. The sensors are calibrated using diagnostic equipment. This also requires a special numerical code.

Documentation

- After starting the system print system label (↓ Fig. 37) and put it on the vehicle.

This way the vehicle can be reset using the old functions any time.

Order number for the sytem label: 899 200 922 4

9.1 PC Diagnostics

Apart from the WABCO Diagnostic Controller (DC), which is not described in more detail in this manual, the use of a PC, also known as a desktop computer is surg-ested.

The requirements for a diagnostics with a PC are:

Software	446 301 520 0
Interface (incl. Cable)	446 301 021 0
Diagnostic Cable Trailer	446 300 329 0

The actual version of the diagnose software is available for free on [www.wabco-auto.com / Downloads](http://www.wabco-auto.com/Downloads).

WABCO		TRAILER ECAS				
HERSTELLER MANUFACTURER CONSTRUCTEUR	Muster	Parameter: Wert Parameter: value Paramètre: valeur				
WABCO TEILENUMMER WABCO PART NUMBER REFERENCE WABCO	446 055 070 0	0: 18	11: 255	22: 20	33: 0	44: 0
SERIENNUMMER SERIAL NUMBER NUMERO DE SERIE	000607	1: 28	12: 255	23: 0	34: 0	45: 0
DIAGNOSEKENNUNG DIAGNOSTIC ID IDENTIF. DIAGNOSTIC	12 91 03 37	2: 4	13: 5	24: 15	35: 0	46: 0
FAHRGESTELLENUMMER CHASSIS NUMBER NUMERO DE CHASSIS	XYZ123	3: 0	14: 25	25: 255	36: 0	47: 20
ZEICHNUNGSNUMMER DRAWING NUMBER NUMERO DE SCHEMA	8418007680	4: 0	15: 6	26: 0	37: 0	48: 0
PARAMETERSATZ-NUMMER PARAMETER SETTING NO. NO. DE LA LISTE PARAMETRES	180000XXXX	5: 115	16: 12	27: 0	38: 0	49: 0
		6: 0	17: 8	28: 0	39: 0	50: 0
		7: 115	18: 255	29: 0	40: 120	51: 0
		8: 0	19: 0	30: 0	41: 25	52: 0
		9: 4	20: 10	31: 0	42: 0	53: 0
		10: 255	21: 0	32: 0	43: 0	54: 0
FAHRHOEHEN (mm) DRIVING LEVEL (mm) NIVEAU DE ROULAGE (mm)	VORN FRONT AVANT			HINTEN REAR ARRIERE		
				A		
TYP TYPE TYPE				430		
NORMALNIVEAU I NORMAL LEVEL I NIVEAU NORMAL I						
SERVICE D-180-2232337 http://www.wabco.de						

Fig. 37 System Label (PC-Print)

The Diagnostic Software has the following Functions:

- Startup of the ECAS system,
- Troubleshooting,
- Activation of the valve,
- Testing and measuring values,
- Analyse ECU data,
- Functional testing,
- Printing the diagnostic memory and system label.



Diagnostic operation on a vehicle with two separate lifting axles will cause the second lifting axle to be lowered. This is due to the way a spring-returned lifting axle valve works.

At the beginning of diagnostic, the lifting axles are deactivated. After diagnostic, the lifting axle again behaves according to the parameters set.

9.1.1 PIN

After receiving a special code number the user can change the settings apart from the diagnostics.



A special code number is only handed out after taking part in system training. It is not allowed for the user, to pass the special code number to another person without the special training. Driving and functional safety could be influenced otherwise.

- To receive your special code number please contact pin@wabco-auto.com. Specify the serial number of the diagnostic software.

It is found on the programme disc's label below a bar code and starts with SN ... This number must be identical to the serial number in the programme – found under "Options" → "Enter PIN". If the two numbers are not identical, the serial number given in the programme is invalid.

The ECAS system is maintenance-free. The system monitors itself by means of the fault routines which are part of the ECU program. If ECAS recognises a failure the signal lamp will be flashing. Only in this case ECAS needs to be checked in a workshop.



Please check the correct height and position of the vehicle.

Control signal lamp during the ignition.

9.1.2 Initializing the ECU

The electronic control unit has to be initialised for diagnostics, i.e. the PC registers with the ECU for the transfer of data.. There are two ways to achieve this:

- The data line is activated for 1.8 seconds.
- The ECU is addressed via its device address (5 baud address).

After initialisation, the ECU will interrupt its normal programme sequence and "report" to the PC as being ready to receive.

The connection is maintained until:

- The PC "signs off",
- The ignition is switched off,
- The data lines are interrupted.

This method is also used for exchanging data between the PC and other ECUs, e.g. the ABS- or EBS-ECU.

- To facilitate diagnostics, the data cables are conducted from ABS or EBS and ECAS to the diagnostic port on the bottom part of the ECAS housing.



The housing does not need to be opened for diagnostics.



The exact wiring is shown in the circuit diagrams contained in chapter 12 "annex".

Due to several combined data lines in one diagnostic port, it is advisable to initialise the system only via the equipment address:

The equipment addresses have been defined in an ISO standard:

- Motor Vehicle ABS 08
- Trailer ABS 10
- Trailer EBS 11
- Motor Vehicle ECAS 16
- Trailer ECAS 18
- etc.

Initialisation at 1.8 seconds would mean that all systems connected to the data line would respond simultaneously and thus cause a jumble of data.

In the (unlikely) event that ECAS ECU does not respond to the call via the equipment address, an initialisation attempt of 1.8 seconds can be made if the combination ABS/ECAS is being used.

- Make sure that the right address is selected.
- However, the diagnostic line for ABS has to be disconnected first.
- When the connection is then established, the parameter for setting the ISO address in the ECU should be checked.

9.2 Setting Parameters

9.2.1 Option Parameters

Option parameters can be expressed by setting or not setting a bit. They are defined as YES or NO, or as "1" or "0", to use computer language. They have no dimensions.

One byte comprises 8 bits, i.e. 8 option parameters. They are clearly shown as numbers between 0 and 255. These apply to information regarding the functional scope and the desired mode of operation for the system e.g.:

- The existence of a lifting axle, the type of lifting axle,
- The definition of the position of height sensor,
- The presence of a pressure sensor, traction help, load sensing valve,
- The type of driving level,
- The definition of plausibility error detection.

9.2.2 Value Parameters

Value parameters are numerical values defining the reference, limit and tolerance values for the system. These values are numbers between 0 and 255. They are proportional values for actual physical dimensions such as:

- Travel,
- Pressure,
- Time,
- Speed.

Eight option parameters can also be combined to arrive at one value parameter.

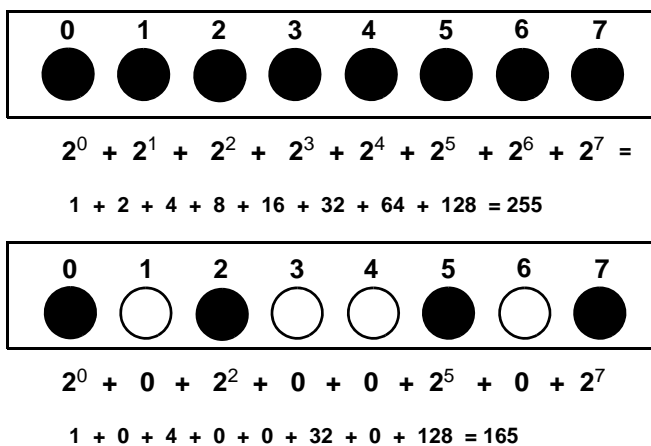

Fig. 38 Model Representation of Numbers 255 and 165 in Digitalised Form (Example)

One byte can be illustrated at follows:

8 lamps are placed on a strip with terminals 0 to 7. If one lamp is on, this equals the number "2 raised to the power of the terminal number".

Example:

The lamp on terminal 3 is on. This equals $2^3 = 8$.

If the lamp is off, this is equal to the figure 0. There are a total of 256 different combinations for illuminating the lamps.

Since an option parameter merely needs to be described as YES or NO (lamp ON or OFF) 8 option parameters then represent one value parameter. These 8 option parameters represent one value parameter.

The parameters can be set using the appropriate software.

In this step, parameter records can, for example:

- Be read in, displayed and stored in a PC from an existing ECU;
 - be written into an ECU from a PC;
 - be manually created and modified in the PC and stored, i.e. transferred to an ECU.
- The parameter record stored in the ECU should be transferred to the PC.

This provides a back-up copy which can be used to store the final set of parameters in the ECU at any time. This particularly important if existing sets of parameters are to be modified. Any number of data records can be stored in the PC.

9.2.3 Counts

Counts are count values produced by the ECU. The basis for these counts are the binary number explained above. The counts range from 0 to 255.

When the parameters – i.e. the reference values for control – are being set, they are set as counts. To allow the ECU to compare reference values and actual values, the actual values also have to be provided as counts.

The values picked up by the sensors are based on distances or pressures. They are transmitted to the ECU as voltages or current pulses. The ECU then converts these signals into digital values, the so-called counts (the signals are being digitalised).

The band width of the voltages and pulse times within the measuring range is divided into equal parts for this purpose.

The maximum measuring range equates to 256 steps.

The smaller these steps are, the:

- more accurate are the measured values provided for computation.
- smaller is the band width to be cover.

The bigger these steps are, the:

- less accurate are the measured values provided for computation.
- wider is the band width to be covered.

These facts must be taken into account when choosing the lever length for the height sensor.

(↑ 8.1.1 Height Sensor - Important for Installation)

9.2.4 Explanation of Parameters

Precondition:

- The diagnostic equipment has been properly connected.
- The ignition has been switched ON.
- Section "Parameters" within the diagnostic programme has been addressed after activating the special function by entering the PIN.

Now the parameters from the vehicle's ECU or from the PC path can be transferred, displayed and changed.

The number of the parameters chose according to the design of the parameter record for ECU variant 446 055 065/066 0.

The design of the parameter record for ECU variant 446 055 060/070 0 has been modified.

! If the parameter number is different from the parameter number for ECU variant 446 055 065/066 0, the changed parameter is shown in brackets in the headings for the individual.

! Please do not change any parameters unless you have attended a special system training course.

Parameter 0

Parameter 0 sets the equipment address which allows the diagnostic equipment (PC) to address the ECU.

👉 For the ECU of Trailer ECAS, this address has been standardised to 18.

Any exceptions are permissible only if a vehicle has had more than one ECU fitted and these share one diagnostic interface.

- The parameters 1 to 4 define the scope of the system.

- In ECU variants 446 055 060/070 0 the parameters 1 to 3 define the scope of the system.

They have each been established by combining 8 YES/NO commands (option parameter).

Parameter 1

Bit 0: Separate Lifting Bellows Valve

Bit 0 must be ZERO for reasons of compatibility.

For the input value for all ECUs 446 055 065/066 0 applies:

- Set input value **👉** Bit 0 = 0.

The following only applies value to ECU variant 446 055 060 0:

- It is set to Bit 0 = 1, if the block of solenoid valves for lifting axle control has a separate solenoid for actuating the lifting bellows.

The solenoid valve is connected to Connection X18 (only ECU variant 446 055 060 0).

Otherwise, controlling only one solenoid simultaneously achieves disconnection and evacuation of the supporting bellows on the lifting axle and increasing the pressure in the lifting bellows (Bit 0 = 0).

Bit 1: Air Suspension on Front and Rear Axle

- If only the rear axle is controlled, set Bit 1 = 0.

This value of 0 permits two lifting axles to be independently controlled in addition to the rear axle.

For drawbar trailers:

- Set Bit 1 = 1.

Rear axle(s), front axle(s) and a separate lifting axle can be controlled independently from each other. In addition, this can be used to achieve right/left control.

Bit 2: Trailers with/without Lifting/Trailing Axle

- If the vehicle has a lifting/trailing axle or if traction help is to be implemented, set Bit 2 = 0.

- Otherwise set Bit 2 = 1.

Bit 3: Implement Lifting/Trailing Axle Control with/without a Pressure Sensor

- Set Bit 3 = 0 to implement fully automatic lifting control.

This setting allows:

- Automatic lowering of the lifting axle/ increasing the weight on the trailing axle when a defined maximum pressure in the supporting bellows is reached and
- raising of the lifting axle / reducing the weight on the trailing axle when the pressure in the supporting bellows falls below a defined minimum value.

This requires a pressure sensor to be fitted in the system.

- The pressure values are defined in Parameter 28 and 29 or 45 and 46 according to the configuration of lifting axles.

In addition, traction help or manoeuvring aid can be implemented.

- For this purpose, Parameter 2 (Bit 0 and 1) and Parameters 32 to 38 have to be set.

Compensating the tyre deflection can also be provided.

- The threshold values for this are defined by Parameters 42, 43 and 44.

Bit 3 = 1 means that the system does not have any pressure sensor. If there is a lifting axle in the vehicle, this is controlled by means of a pressure switch. However, this only permits the lifting axle to be lowered.

The command for raising the lifting axle then has to be given from the remote control unit or push-button.

In combination with EBS, the ECAS-ECU receives the data from the pressure sensor via the K-line.

- In this case, set Bit 3 = 1.

Bit 4: Number of Height Sensors Rear Axle

- Set Bit 4 = 0 to make the system assume 2-point control on the rear axle.

With two height sensors and a solenoid valve with two 2/2-way valves, the level can be kept in parallel to the axle even though the load on either side of the vehicle may vary. The supporting bellows on each side of the superstructure are controlled separately.

- Set Bit 4 = 1 to make the system assume 1-point control on the rear axle.

With the height sensor, which is usually sited in the centre of the axle, the supporting bellows are actuated by a solenoid valve with a 2/2-way valve.

A transverse throttle between the two valve outlets of the valves permits the pressure of the supporting bellows on both sides of the vehicle to be balanced slowly.

A one-sided load can result in the negative effect of a tilting superstructure.

- Set Bit 4 = 1 if active left/right control is to be achieved on a semi-trailer with two height sensors.

- One of the height sensors (on the left) is then plugged into Connector X12 for the front axle, and the second one (on the right) to X13 for the rear axle.

Bit 5: Defining the Side of the Height Sensor for System with only one Sensor

- Bit 5 = 0 Height sensor left to Connector X14
- Bit 5 = 1 Height sensor right to Connector X13

The base plate of ECAS-ECU offers two ways to connect a height sensor.

In systems with only one height sensor on the rear axle, this bit is used to indicate whether it is connected to the Connector X14 (left) or Connector X13 (right) in the ECU.



In this case, left/right has nothing to do with the location in the height sensor on the vehicle.

The following only applies value to ECU variant 446 055 060 0:

If two pressure sensors are being used, the side allocation of the pressure and height sensors must be taken into account.

- The pressure sensor must be connected to Connector X5 if the height sensor connected to Connector X14 (left).
- The pressure sensor must be connected to Connector X4 if the height sensor connected to Connector X13 (right).

Two pressure sensors are used very rarely on trailers. Usually only one pressure sensor is used.

Bit 6: Number of Calibration Level

For the calibration process, the ECU expects three levels to be addressed.

- Driving Level I, the upper and the lower level then have to be addressed and calibrated.

- Set  Bit 6 = 0 (standard setting) for vehicle with:
 - that have a remote control unit.
 - on which a remote control unit can be fitted.
- Set Bit 6 = 1 for:
 - if upper/lower levels are known and
 - in exceptional cases.

- Prior to the calibration process, the upper/lower levels must be stored in the ECAS-ECU as counts from the PC.

- During the calibration process, Driving Level I is then addressed and calibrated.

Bit 7: Automatic Recognition of Peripherals

- If Bit 7 = 0, the ECU must be informed of the whole system configuration in the option parameters.
- If Bit 7 = 1, the ECU checks the electrical connections prior to calibration and then concludes which system configuration is being used.

The parameters for the description of the system configuration (Parameter 1: Bit 0, 1, 2, 4, 5; Parameter 2: Bit 5; Parameter 3: Bit 0) are then set automatically when a parameter is changed and/or when the calibration process is repeated.

Even though the Bit 7 has been set, the parameters still have to be set as well. For example, the ECU is not aware:

- whether a pressure switch has been connected.
- how traction help is to operate.

Parameter 2**Bit 0: Traction Help Type "Germany"**

- Set Bit 0 = 0 if a vehicle is registered according to the German motor vehicle construction and use regulation.

Traction help will then only be effective for a limiting time after it has been activated. It cannot be activated again until a forced delay period has passed.

- These periods are defined by Parameters 32 and 34.
- Activate traction help by using the button on Connector X9.

The traction help version called "other countries" Bit 0 = 1 is also active for a defined time.

- However, it can be extended as needed by the button again once or repeatedly (↓ Parameter 33).

When EC Directive 97/27/EC comes into force, the time limit for the traction help will no longer apply. The traction help will then be designed according to axle weight criteria and a speed threshold.

- Set 👍 Bit 0 = 1.

The time for the traction help for "other countries" is active as defined by Parameter 33.

- For EC traction help set 255 counts on Parameter 33 and 0 counts for Parameter 34.
- Activate traction help by using the button on Connector X9.

- ! Other threshold values for traction help are defined in ↓ Parameter 35 to 38.

Bit 1: Traction Help Type "Nordic"

- Set Bit 1 = 1, to activate traction help type "Nordic". Traction help type "Nordic" permits the time for which the traction help is to be active to be freely defined by the driver.
- Time for which the traction help is to be active by using the button on Connector X9.

Bit 2: Driving Level II via Switch Position/Remote Control Unit or Limiting Speed

- Set Bit 2 = 0.
- If a limiting speed defined by Parameter 25 is exceeded, Driving Level II defined in Parameters 23/24 is addressed.
- When the speed falls below a limiting speed defined in Parameter 26, Driving Level I is addressed again.

This function makes sense for special applications.

- Set 👍 Bit 2 = 1.

Driving Level II can be addressed by means of a switch (Connector X8), or by means of the remote control unit if ECU variant 446 055 065/066/075 0 is used.

Bit 3: Manual/Fully Automatic Lifting Axle Control

- Set Bit 3 = 0 to allow manual lifting control.

If a system with a pressure switched is used, the lifting axle is lowered. This also happens when the pressure in the supporting bellows indicates that the weight on the leading axle is excessive.

- After reducing that weight, however, the lifting axle has to be raised again manually via a switching contact or by means of the remote control unit.
- The lifting axle also has to be raised manually or by means of the remote control unit if Bit 3 is set to 0 on systems which have a pressure sensor.
- Set 👍 Bit 3 = 1, to preselect automatic lifting axle control.

This setting allows:

- Automatic lowering of the lifting axle/ increasing the weight on the trailing axle when a defined maximum pressure in the supporting bellows is reached and
- Raising of the lifting axle / reducing the weight on the trailing axle when the pressure in the supporting bellows falls below a defined minimum value.

This requires a pressure sensor for the whole of the system.

- Depending on the lifting axle configuration the pressure values are defined in Parameters 28 and 29, and in Parameters 45 and 46 if the system uses two separate lifting axles.

Bit 3 = 1 is also required for a system using traction help.

Bit 4: Pulse-Controlled or Spring-Returned Lifting Axle Solenoid Valve

The ECAS solenoid valve or the lifting axle portion of the ECAS solenoid valve block for actuating the lifting axle bellows is used for implementing a pulse-controlled valve if Bit 4 = 0. In this case the lifting bellows are actuated via a pressure pulse on slides inside the solenoid valve (the usual case on trailers).

- The lifting axle valves shown in the WABCO diagrams require  Bit 4 = 0.
- Bit 4 = 1 is used to implement lifting-bellows control with a spring-return valve.

The lifting bellows are actuated by a continuous pressure acting on a spring-loaded piston in the ECAS solenoid valve. This is fairly rare on trailers.

Bit 5: Additional Valve for Traction Help

- Set  Bit 5 = 0, if no traction help is required, or if a pulse-controlled solenoid valve is being used for traction help (the usual case).

If a spring-return valve is being used for lifting axle control, the traction help facility can only be implemented by using an additional solenoid valve. This solenoid valve then shuts off the bellows on the supporting axle from the lifting axle.

- Set Bit 5 = 1 if an additional solenoid valve is used.

 None of the diagrams contained in this document have an additional valve.

Bit 6: Number of separate Lifting Axles

- Set Bit 6 = 0 for:
 - a drawbar trailer with fully air suspension
 - a semi-trailer with one controlled lifting axle.
 - vehicles with no lifting axle.

Now actuating of only one lifting bellow is possible at the most.

Of course several lifting axle bellows can be connected in parallel.

- The actuating pressure for the lifting axle are defined in Parameters 28 and 29.

- If Bit 6 = 1, the ECU is capable of separately controlling two lifting axles on a semi-trailer.

If this option is used, front axle control is no longer possible.

- The actuating pressure for the lifting axle are defined in Parameters 28, 29, 45 and 46.

Bit 7: Output of Measured Values

- Normally Bit 7 is set to 0.
- If Bit 7 = 1, the ECU will, during the normal operation, continuously transmit 8 measured values.

These measured values are computed from the sensor reading.

- Using the PC, these measured values can be displayed.

The measuring locations have the following allocations:

- 1 Actual value height sensor, rear axle left
- 2 Actual value height sensor, rear axle right
- 3 Actual value height sensor, front axle
- 4 Reference value height rear axle (if different reference values have been set for left/right, the "left" value will be displayed)
- 5 Value height sensor, front axle
- 6 Actual value pressure sensor (several pressure sensors: average value)
- 7 Current offset for compensating for tyre deflection (will increase the reference value for the driving level)
- 8 Current vehicle speed.

Output of measured values 1 to 7 is in counts, output 8 in k.p.h.

If the system does not possess one of the measuring locations (e.g. measuring location 3 in the system without air suspension on the front axle), a value of 0 or 255 will be returned.

 The output of measured values may be used only in connection with the process of setting parameters. Since the ECU continuously transmits data, diagnostics is not possible without a PIN. To end the process of setting the parameters, Bit 7 must be set to "0" because otherwise no troubleshooting can be done without a PIN.

Parameter 3

Bit 0: Load Sensing Valve

- Set 👍 Bit 0 = 0.
- If this bit is set to "1", a separate 3/2-way solenoid valve is energised as long as the system is working properly and the level is higher than the rubber buffers.

It is energised as long as long as the system is working properly and the level is higher than the rubber buffer. If this is not the case the solenoid valve applies the full supply pressure to control port 41 and 42 of the load sensing valve.

! This special application is shown in the diagrams. (↓ 12. Annex)

Bit 1: Monitoring the C3 Signal with Error Recognition

- Set Bit 1 = 0 (standard setting) to permit normal error recognition.
- To permit extended error recognition, i.e. a short to ground can be detected, set Bit 1 = 1.

! The function is possible only for VCS.

Bit 2: Switch-Off Function if a Plausibility Error occurs

- If Bit 2 = 0, the occurrence of a plausibility error (↓ Parameter 40) cause the error to be detected and the system switched off.
- For vehicle with a frame which has particularly low torsional resistance and which are driven in difficult terrain (e.g. pole vehicle), it should be set to 👍 Bit 2 = 1.

In the event of a plausibility error, only the ECAS solenoid valves would then be switched off and the current actual level is perceived as the reference level.

Bit 3: Transmission of Operational Data on the K-Line

- Set Bit 3 = 0 for ECAS working together with ABS. No operational data for ECAS are transmitted on the K-line.
- Set Bit 3 = 1 for ECAS working together with EBS. Data required for the operation of ECAS are transmitted from EBS to ECAS on the K-line Data means:
 - Speed Signal,
 - Pressure Sensor Signal.

In order to be able to work together with EBS, ECAS does not require its own pressure sensor.

The pressure sensor for ECAS alone has priority over the EBS pressure sensor if:

- a pressure sensor for ECAS is connected to Connector X5 on the ECU.
- Parameter 1 Bit 3 is set.

Bit 4: Pressure Sensor Resolution

- Bit 4 = 0 for pressure sensors which, at 10 bar, have a voltage output of 5.5 volt to the signal line.
- Bit 4 = 1 for pressure sensors which, at 10 bar, have a voltage output of 4.5 volt to the signal line.

Bit 4 = 0 for 1 count then equals 1/20 bar (= 0.05 bar).

Bit 4 = 1 for 1 count then equals 1/16 bar (= 0.0625 bar). The pressure sensors with this resolution have a DIN bayonet connector and are standard components for Trailer EBS and ECAS.

Bit 5: Select Unloading Level - Driving Level III

- Set Bit 5 = 0 for the unloading level. It is activated using a switch.
- Set Bit 5 = 1 for Driving Level III. It can be addressed with a separate switch or via the remote control unit.

The values for the level are defined in Parameter 5/6.

Bit 6: Actuation of Driving Levels II and III

Driving Level II (Parameter 2 Bit 2 = 1) and/or Driving Level III (Parameter 3 Bit 5 = 1) can be addressed:

- With a separate switch (Bit 6 = 0),
- Via the remote control unit (👍 Bit 6 = 1).

Bit 7: Addressing the Driving Level when Superstructure is raised

- Set Bit 7 = 0 (standard setting) on vehicles with one height sensor installed on its rear axle, the current driving level is addressed directly.
- Set Bit 7 = 1.

Before the driving level is addressed, the vehicle's superstructure is lowered slightly and then raised to its driving level by simultaneously pressurising the bellows. This function applies to vehicles with two or more height sensors. This Bit must be set for vehicles with left/right control.

This ensures a balance in pressures on the left-hand side and the right-hand side.

Parameter 4

Bit 0: Modify Traction Help Pressure

- Set Bit 0 = 0 to adhere the traction help pressure as defined in Parameter 37.
- Set Bit 0 = 1 so the permissible traction help pressure as defined in Parameter 37 is increased by Parameter 28 by a maximum of 10% .

This increase by 10% becomes active if at the beginning of the traction help the bellows pressure > Parameter 28.

This type of traction help is advisable if the pressure defined in Parameter 28 is lower than the permissible pressure of the axle assembly for the defined braking performance. In this case, Parameter 37 (= Parameter 28 • 130%) would be too low as the limiting pressure for the traction help.

By setting the Bit accordingly the pressure limit for the traction help facility is extended. The purpose being to control the different axle assemblies by a small number of parameters.

Bit 1: Lifting Axle Behaviour after Ignition OFF

(From Software Version V_9.1.1.D Upwards)

- Set Bit 1 = 0 (standard setting), to cause the lifting axle(s) to be lowered when the ignition is switched OFF. The lifting axle(s) will be lowered only if contact at Terminal 30 is maintained for a short time after the ignition has been switched off. This does not apply after the ABS connection has been severed.
- Set Bit = 1, so the lifting axle remains raised after the ignition is switched off.

Bit 2: Lifting Axle Behaviour after Ignition ON

(From Software Version V_9.1.1.D Upwards)

- Set Bit 2 = 0 (standard setting), this causes the lifting axle to be raised when the ignition is switched ON, provided the axle load permits this.
- Set Bit 2 = 1, so the lifting axle stays on the ground after the ignition is switched ON.

The lifting axle will not be raised until a limiting speed defined by setting the appropriate parameter (↓ Parameter 51) is reached.

 Bit 2 can only be set to 1 if Parameter 2 Bit 3 = 1 (fully automatic lifting axle operation).

This has a positive effect on construction vehicles and on motor vehicles with a poor cold start ability (no lifting axle swing).

The decision on whether the lifting axle(s) can be raised is made while the vehicle is stationary. (For this reason the axle will not be raised until after the vehicle has been stopped and subsequently exceeds the limiting speed.)

Bit 3: Reference for raising the Driving Level when the Lifting Axle is elevated

(From Software Version V_9.1.1.D Upwards)

- For raising the driving level when the lifting axle is elevated set for the lowest driving level Bit 3 = 0.
- Set Bit 3 = 1 for raising the driving level when the lifting axle is elevated for Driving Levels I and II .

At Driving Level III, the driving level is not raised when the lifting is elevated. Driving Level III should be the highest of the three possible driving levels.

- The amount, by which this driving level is raised when the lifting axle is elevated is defined by Parameter 39.

 The level will be raised only if the vehicle is actually at its driving level.

Bit 4: Effect of Switching Input " Automatic Lowering of the Lifting Axle" - Connector X15 on the ECU

(From Software Version V_9.1.1.D Upwards)

 Set this Bit only for two separate lifting axles.

Setting is only possible if Parameter 2 Bit 6 = 1.

- For the effect of switching input "automatic lowering of the lifting axle on all lifting axles" set  Bit 4 = 0.
- For the effect of switching input "automatic lowering of the lifting axle on the 2nd lifting axle only" set Bit 4 = 1.
- Set the remaining Bits 5 to 7 = 0, they are irrelevant.

Parameter 5

Difference between Unloading Level or Driving Level III and Driving Level I on the Front Axle (Parameter 4)

- This parameter for the front axle is set similarly to Parameter 6.
- The setting is 0 count if no front axle or left/right control of the rear axle is performed.

Parameter 6

Difference between Unloading Level or Driving Level III and Driving Level I on the Rear Axle (Parameter 5)

 This parameter depends on the setting of Parameter 3 Bit 5.

Parameter 6 defines the level which becomes effective when the unloading-level switch / the switch or button on the remote control unit for Driving Level III is actuated.

- Set a value for Parameter 6 between 0 and 99 counts, if the level is to be higher than Driving Level I.

This value is then added to Driving Level I.

- Set a value for Parameter 6 greater than 100 counts, if the level is to be higher than Driving Level I.

This value is then subtracted from Driving Level I to arrive at the new reference value.

- Set Parameter 6 to 0 count, if no Unloading Level or Driving Level II is required.

Parameter 7

Limit for the Recognition of Plausibility Errors on the Front Axle (Parameter 6)

- The setting is 0 count if no front axle or left/right control of the rear axle is performed.

↓ See description for Parameter 8 - similar function.

Parameter 8

Limit for the Recognition of Plausibility Errors on the Rear Axle (Parameter 7)

Parameter 8 defines a value for the height sensor.

When this is exceeded while the superstructure is being lowered, the ECU does not perceive a plausibility error (↓ Parameter 40). Depending on the definition of the lowest permissible level, the function of Parameter 8 varies:

- **The Lower Height Limit (Lowest Possible Limit) is to the Rubber Buffer.**
- Parameter 8 is to be chosen to be greater than 100 counts.

An unladen vehicle does not compress the rubber buffer as much as a laden vehicle. Therefore the value to be entered is determined by the elasticity of the rubber buffers.

If the calibration was done on the laden vehicle, the unladen vehicle will be able to reach this lowest possible level even when the bellows are evacuated completely.

This causes a plausibility error to be reported. The ECU recognises the rubber buffer and ends the evacuation process when:

- the total is less than lower level + Parameter 8 - 100 and
- no further change in height takes place within the time

defined in Parameter 18 (buffer recognition time).

This prevents the total evacuation of the bellows. The level thus reached is then assumed to be the new reference level.

- If calibration is done on the unladen vehicle, a value between 110 and 125 counts should be chosen for Parameter 8.

- On new vehicles set for Parameter 8 a value of 👉 115 counts.

This is to ensure that no plausibility error is detected even when the vehicle is in a tilting position and thus resting on the buffers on one side.

- If calibration is done on the unladen vehicle, a value between 120 and 135 counts should be chosen for Parameter 8.

- **Lower Height Limit lies above the Rubber Buffer.**

- Parameter 8 is to be chosen to be less than 100 counts.

The evacuation process is ended as soon as:

- the total is less than the lower level + Parameter 8 and
- no further change in height takes place within the time defined in Parameter 18 (buffer recognition time).
- As plausibility problems usually occur only when the vehicle is in a tilting position or on an uneven surface, a setting between 5 and 20 counts is recommended.
- On new vehicles set for Parameter 8 a value of 👉 15 counts (standard value).

If, during a lowering process, no downward height change is perceived within 30 seconds above the limiting value, the ECU will consider this to be a plausibility error.

Limiting Value = Parameter 8 + Stop Level

If the value is greater than 100 counts, the buffer can always be reached via the remote control unit. Regardless of the lower level which has been calibrated.

Parameter 9

Permissible Tolerance of Reference Level on the Front Axle (Parameter 8)

- The setting of Parameter 9 is 0 count if no front axle or left/right control of the rear axle is performed.

↓ See description for Parameter 10 - similar function.

Parameter 10**Permissible Tolerance of Reference Level on the Rear Axle (Parameter 9)**

Together with the proportional and differential coefficients, the setting of this parameter determines the control performance of the system on the rear axle. (↑ 5.1 Control Algorithm for Levelling Control)

The tolerance value entered defines the amount by which the reference level on the rear axle may vary either way. The tolerance range is thus the input value x 2.

- Set input value for Parameter 10 greater than 2 counts (👉 4, 5 or 6 counts).

Parameter 11**Permissible Right/Left Deviation in Reference Level (Parameter 10)**

Parameter 11 is effective only in systems with two height sensors on the rear axle. It defines the permissible slant of the superstructure if the load is not evenly distributed.

- Set Parameter 11 on 👉 4, 5 or 6 or 255 counts.

! Values greater than Parameter 10 x 2 are not accepted by the ECU.

- Except when independent wheel suspension is being used, axles are so torsion-resistant today that a setting of 255 is recommended.

Parameter 12**Permissible Right/Left Deviation for Raising/Lowering (Parameter 11)**

Parameter 12 applies only to axles with two height sensors. Unlike Parameter 11, it is not the control process around the reference level which is being specified but the process of greater level changes (raising/lowering).

On a vehicle with a greater load on one side, the side which has less weight on it will be raised more rapidly than the other. The side which has heavier load will be lowered more rapidly thus causing a dangerous slant as the level is being changed.

By pulsing the bellows supporting the lighter load, a more even raising/lowering process is achieved.

- Set Parameter 12 on 👉 4, 5 or 6 or 255 counts.
- Except when independent wheel suspension is being used, axles are so torsion-resistant today that a setting of 255 can be recommended.

Parameter 13**Permissible Front/Rear Deviation for Raising/Lowering (Parameter 12)**

When the height of the vehicle which has full air suspension is being changed, the front and the rear of superstructure should reach the new reference level simultaneously. The axle above with the shorter distance needs to be covered is raised/lowered at the correspondingly slower rate.

! A minor permissible deviations causes constant pulsing of the solenoid valves during the control process and should, therefore, be avoided.

- For drawbar trailers set Parameter 13 between 👉 15 and 30 counts.
- For semi-trailers with left/right control set Parameter 13 on 👉 255 counts.

Parameter 14**Permitted Level Increase 7 Seconds after Moving Off or when Unloading Level Function (Parameter 13) has been activated**

While the vehicle is in motion, the reference level is being controlled according to the setting for Parameter 27 (Standard: after a delay of 60 seconds).

Unloading the vehicle while it is moving slowly is in fact common practice. Due to the delays in the control process while the vehicle is moving (delay time), the vehicle's superstructure would then be above the reference level for a time due to the sudden reduction in weight caused by the unloading process. Parameter 14 permits the reference level for the height of the superstructure above the axle to be exceeded.

If all height sensors of the system indicate within 7 seconds after the vehicle has moved off or if the unloading level has been activated that the reference level + Parameter 14 has been exceeded, the ECU will recognise that unloading is in process. It will immediately initiate the control process for a level which is reference level + Parameter 14.

! Parameter 14 should not be 0 count. Because this would mean that the control process would commence every time reference level + Parameter 14 (= 0) is exceeded.

- Set Parameter 14 to 👉 20 counts.

If the "unloading level" function is active, any change in the height which is greater than "reference level + Parameter 14" will immediately cause the control process to commence. Even when the brakes are being applied. The control process will continue as long as the vehicle has not exceeded a speed of k.p.h. since moving off. The vehicle is being driven at a speed faster than 10 k.p.h., this control process ends and will recommence only when the vehicle has been stopped and is moving again.

Parameter 15

Vehicle Speed up to which the Deliberate Level changes can be achieved (Parameter 14)

Parameter 15 describes the limiting speed up to which the remote control unit's controls are active while the vehicle is moving (remote control unit looped through to the motor vehicle). This allows memory levels, raising, lowering, etc. to be executed.

When the speed defined by Parameter 15 is exceeded, the remote control unit is switched off.

A level which is different from the driving level will then continue to be addressed until the speed defined by Parameter 41 for returning to the driving level is exceeded.

! The value for Parameter 15 is restricted for Parameter 41. The pressure value for Parameter 15 must be smaller than Parameter 41.

- Set Parameter 15  between 10 and 20 km/h.

Parameter 16

Control Delay while Vehicle is stationary (Parameter 15)

Parameter 16 defines a period of time. In this period the height sensor signals have to have been outside the permissible tolerance range for the reference value to trigger a readjustment.

Input values are in steps of 250 milliseconds per count.

- Set Parameter 16 to  8 counts.

Parameter 17

Length of Pulse Period T (Parameter 16)

Parameter 17 defines the length of a pulse period for controlling a reference level.

- Set a pulse length of  12 counts (equalling 300 milliseconds).

Input values are in steps of 25 milliseconds per count.

The pulse period is the difference between two actuating pulses for the 2/2-way valves inside the ECAS solenoid valve. The actuation period of the 2/2-way valves is determined by the ECU on the basis of the control deviation and the speed at which the control deviation is being changed. If the computed actuation period is equal to or greater than the length of the input for the pulse period, the 2/2-way valves are energised continuously.

(↑ 5.1 Control Algorithm for Levelling Control)

Parameter 18

Buffer Recognition Time (Parameter 17)

Parameter 18 defines the time in which the ECU is to recognise the lower stop ("rubber buffer").

If after output of the command "lower superstructure" the height is not changed further within this time and the height of the superstructure above the axle corresponds to the setting of Parameter 7 or 8.

The pulsing of the ECAS solenoid valve is stopped. Input values are in steps of 250 milliseconds per count.

- Set Parameter 18 between 40 and  80 counts.

Parameter 18 Pulse divider (only for ECU variants 446 055 060/070 0).

Parameter 18 indicates the time portion of a period in the rapidly moving side of the superstructure during the raising/lowering process. This happens together with Parameter 11 and 12 of ECU variant 446 055 060/070 0.

Pulse times which are shorter than 75 milliseconds are not executed.

- Set Parameter 18 to  255 counts.

On the side moving more rapidly the solenoid valve is closed until the superstructure is once again within the tolerance as defined by Parameters 11 or 12.

- Parameter 18 should be set to 0 count.

Thus would correspond to an open valve solenoid on the side moving more rapidly.

! Parameter 18 is only set for ECU variant 446 055 060/070 0. This parameter has not been used in operation or set to 255 counts. For this reason, this parameter is no longer used in more recent systems.

Parameter 19**Proportional Coefficient K_{PF} for controlling the Reference Level on the Front Axle**

↓ See description for Parameter 20 - similar function for front axle control.

Parameter 20**Proportional Coefficient K_{PR} for controlling the Reference Level on the Rear Axle**

The proportional coefficient K_P is a basic value for ECAS controlling the reference value. It is used to compute the pulse length for level control.

The pulse length to be computed is proportional to the existing control deviation. Thus the ECU has to be given a proportionality factor – the proportional coefficient K_P – so that it can compute the pulse length. The proportional coefficient K_P is dependent on the system configuration.

It has to be determined by trials and then defined more precisely. This is done by the vehicle manufacturer and usually not required for servicing.

It is determined as follows:

- Set Parameter 11, 12 and 13 to 255 counts.
Set Parameter 17 to 👍 2 counts.
Set Parameter 10 👍 between 3 and 5 maybe up to 7 counts.
For front axle control use Parameter 9.
- Determine a (starting) value for K_P according to the equation:
$$K_P = (\text{Parameter 17} - 2) / (\text{Parameter 10} - 1)$$

Parameter 17 = Length of Pulse Periode
Parameter 10 = Reference Level Tolerance Rear Axle
For front axle control use Parameter 9.
- Determine the input Parameter according to the equation: $\text{Parameter 20} = K_P \times 3$
Round to full figure. (For front axle control:
 $\text{Parameter 19} = K_P \times 3$)
With this value, the slowest raising rate and the smallest reference level deviation to be controlled would just cause the ECAS solenoid valve to be energised continuously.
- Calibrate vehicle
- Take vehicle to a level below the reference value tolerance for the current driving level, followed by the "driving level" command via remote control unit.
- Make sure, that the driving level being addressed without overshooting and without the solenoid valve pulsing.

– Result:

- YES: K_P is okay and can stay the way it is.
- Superstructure is overshooting:
Reduce K_P value an increase reference value tolerance if applicable.
- Solenoid valves are pulsing:
Increase K_P value.

– After any adjustment, continue from ↑ "Take vehicle to a level below the reference value tolerance [...]"
Otherwise abort.

It might happen that no compromise can be found for the setting. That means the superstructure's tendency to overshoot cannot be remedied within an acceptable tolerance range for the reference value by adjusting K_P value. A smaller diameter of the pneumatic line between the ECAS solenoid valve and the supporting bellows (smaller line cross-section or throttle) is advisable.

The proportional value K_P is determined in thirds of a count.

- Set Parameter 20 between 8 and 👍 10 counts.

Parameter 21**Differential Coefficient K_{DF} for controlling the Reference Value on the Front Axle**

↓ See description for Parameter 22 - similar function for front axle control.

- Set Parameter 19 x 2, e.g. 👍 20 counts.

Parameter 22**Differential Coefficient K_{DR} for controlling the Reference Value on the Rear Axle**

The differential coefficient K_D is one of the basic values for ECAS reference level control. The period of time in which the ECAS valve solenoid is energised while the superstructure is being raised can be shortened as a ratio of the speed at which the control deviation is being changed. This serves to slow down the raising process in the event of major deviations in the reference levels in order to prevent overshooting. In order to shorten this pulse length, the ECU has to be provided with a factor – the differential coefficient K_D .

The proportional coefficient K_D is dependent on the system configuration. It has to be determined by trials and then defined more precisely. This is done by the vehicle manufacturer and usually not required for servicing.

It is determined as follows:

- Determine a standard value for K_D according to the equation:
 $K_D = \text{Parameter } 20 \times 2$ (= Parameter 22).
 (for front-axle control use this equation:
 $K_D = \text{Parameter } 21 \times 2$)
- Take value into a major reference value deviation below the driving level, followed by the "driving level" command.
- Make sure, that the driving level being addressed without overshooting and without the solenoid valve pulsing.
- Result:
 - YES: K_D is okay and can stay the way it is.
 - Superstructure is overshooting:
 Increase K_D value. K_D should be not greater than $\text{Parameter } 20 \times 4$.
- After any adjustment, continue from \uparrow "Take value into a major reference value deviation [...]" Otherwise abort.

The proportional value K_D is determined in length of pulse period per thirds of a count.

- Set Parameter 20 x 2, e.g. 👉 20 counts.

Parameter 23

Difference Driving Level II to Driving Level I on the Front Axle

↓ See description for Parameter 24 - similar function for front axle control.

Parameter 24

Difference Driving Level II to Driving Level I on the Rear Axle

Parameter 24 defines Driving Level II on the rear axle according to the condition set via Parameter 2, Bit 2.

- Set a value for Parameter 24 between 0 and 99 counts, if Driving Level II is to be higher than Driving Level I.

The value entered is then added to Driving Level I.

- Set a value for Parameter 24 greater than 100 counts, if Driving Level II is to be lower than Driving Level I.

Driving Level II is then calculated as:

Driving Level I - Parameter 24 + 100 counts

Parameter 25

Limiting Speed for Automatically Controlling Driving Level II

Parameter 25 defines a speed above which Driving Level II is addressed. This function is active when Option Parameter 2 - Bit 2 = 0.

- Input is in k.p.h.

Parameter 26

Limiting Speed for Addressing Driving Level I from Driving Level II

Parameter 26 defines a speed below which Driving Level I is addressed. This function is active when Option Parameter 2 - Bit 2 = 0. It is the inverse function derived from Parameter 25.

- Parameter 26 (in k.p.h.) must be smaller than Parameter 25.

Parameter 27

Control Delay when in Motion

The time interval at which the reference level is controlled while the vehicle is in motion can be set by this parameter.

Values of less than 10 seconds (equals 40 counts) are not suitable. For this reason, if a value of less than 40 counts is entered, this is automatically set to 40 counts. However, when the parameter is read out on the PC, the actual input value will be displayed.

- A suitable setting is a control delay of 60 seconds, equalling 👉 240 counts (standard setting).

Parameter 28

Permissible Pressure in the Leading Axle's Supporting Bellows at which the Lifting Axle is lowered or the Weight on the Trailing Axle is increased

Parameter 28 describes the lowering pressure in the supporting bellows on the leading axle. When this pressure is exceeded, automatic lifting axle control becomes effective.

As a consequence, the lifting axle is lowered and thus the axle load distributed across the main and lifting axle(s). This causes the pressure in the supporting bellows to fall.

- 👉 A pressure setting is recommended at which the pressure in the supporting bellows has reached its permissible maximum.

This value is shown, for example, on the reference plate for the load sensing valve or the EBS reference plate.

However, this pressure setting may also be below the permissible supporting bellows pressure.

! It must not lead to the permissible axle weight for the leading axle as defined by the manufacturer being exceeded.

! Section 5.2 "Control Algorithm for Lifting Axle Control" provides further details regarding this subject.

The lowering pressure mentioned there as $p_{LA\ Lower}$ is defined with this Parameter 28.

$$p_{Bellow\ Laden} [bar] \cdot 16 [counts/bar] = \frac{p_{Bellow\ Laden} [bar] \cdot 0.9 \cdot A}{Total\ Number\ of\ Axles} \cdot 16 [counts/bar] = E$$

Input is provided in steps, depending on the type of pressure sensor used, of 1/16 (standard value) or 1/20 bar per count.

Parameter 29

Pressure on the Rear Axle which permits Raising of the First Lifting Axle or Reducing the Weight on the Trailing Axle

In order to achieve automatic raising of the lifting axle(s) when the load on an axle falls below a certain value, a pressure value for the supporting bellows is provided in Parameter 29. After the 1st lifting axle has been raised, the axle load and the weight of the lifting axle must be supported by the axles which remain on the ground. Raising the 1st lifting axle causes the pressure in the supporting bellows on the leading axle to rise.

! The sections 5.2.1 and 5.2.3 give more detailed information on this aspect.

The raising pressure $p_{LA\ Raise}$ (ECAS with one lifting axle) or raising pressure for the 1st lifting axle $p_{LA1\ Raise}$ (ECAS with 2 separate lifting axles) is defined here in Parameter 29.

Input is provided in steps, depending on the type of pressure sensor used, of 1/16 (standard value) or 1/20 bar per count.

– The pressure value for Parameter 29 must be smaller than Parameter 28.

! The exact definition of Parameter 29 is to be found in the sections 5.2.1 and 5.2.3.

$$p_{Bellow\ Laden} [bar] \cdot 0.9 \cdot A$$

E = Input Values [counts]
A = Number of non-lifted Axles

– If two axles are lifted in parallel, factor 0.9 is replaced by 0.8.

Parameter 30

Excess Pressure of the Leading Axle's Supporting Bellows

! Parameter 30 describes the pressure level in the supporting bellow of the leading axle which may never be exceeded. Otherwise this would involve the risk that the axle or the air suspension bellows would be subjected to excessive strain.

If the pressure sensor picks up a reading which is higher than the value defined in this parameter. The superstructure is lowered until it rests on the buffers.

When this happens, the axle load should be reduced (unloading) and the ignition switched off and then on again to return to normal operating conditions.

! If the system includes a pressure sensor, Parameter 30 may not be set to 0 count. ECAS lowers the vehicle until it rests on the buffer.

– If the so-called overload protection is not needed, Parameter 30 should be set to 255 counts.

This is particularly important for vehicles using a combination of EBS/ECAS and which have no lifting axle.

! Section 5.2 provides further details regarding this subject.

Input is provided in steps, depending on the type of pressure sensor used, of 1/16 (standard value) or 1/20 bar per count.

$$p_{Bellows\ Laden} [bar] + 50\% \cdot 16 [counts/bar] = \frac{p_{Bellows\ Laden} [bar] \cdot 0.9 \cdot A}{Total\ Number\ of\ Axles} \cdot 16 [counts/bar] = E$$

Parameter 31

Limit Speed for Manual Lifting/Trailing Axle Control

Parameter 31 defines a speed limit up to which the lifting axle can still be manually controlled.

! Lowering the lifting axle at higher speeds would cause tyre damage due to higher stress values as the tyres make contact with the road surface.

- Set Parameter 31 to  20 k.p.h.

Parameter 31 is ineffective if fully automatic lifting axle/trailing axle control has been selected (Parameter 2 Bit 3 = 1). On vehicles with two separately controlled lifting axles it provides the reference speed for Parameter 51.

 The value for Parameter 15 is restricted for Parameter 41.

Parameter 32

Duration of Traction Help Type "Germany"

Parameter 32 defines the length of time in which traction help may be active.

Due to EC Directive 97/2001/EC (2001), the time limit for the traction help no longer applies.

 Section 5.2.2 "Control Traction Help" provides more detailed information.

Input is provided in steps of 5 seconds.

- Set Parameter 32 to  18 counts.

The decision whether the duration of traction help according to Parameter 32 or 33 shall apply is made in Parameter 2 Bit 0 und Bit 1.

Parameter 33

Duration of Traction Help Type "Other Countries"

Parameter 33 defines the length of time in which traction help may be active. This parameter is set in accordance with national legislation.

 Section 5.2.2 „Control Traction Help" provides more detailed information.

Input is provided in steps of 5 seconds.

Due to EC Directive 97/2001/EC (2001), the time limit for the traction help no longer applies.

- Set Parameter 33 to  255 counts.

In this case traction help is activated permanently.

The decision whether the duration of traction help according to Parameter 32 or 33 shall apply is made in Parameter 2 Bit 0 und Bit 1.

Parameter 34

Forced Delay for Traction Help

Parameter 34 defines the length of the delay between the end of on traction help cycle and the time when traction help can be activated again. Parameter 34 is set according to the applicable German legislation (StVZO) (at present 50 seconds).

 Section 5.2.2 "Control Traction Help" provides more detailed information.

Input is provided in steps of 5 seconds.

Due to EC Guideline 97/2001/EC (2001), the time limit for the forced delay no longer applies.

- Set Parameter 34 to  0 counts.

Parameter 35

Speed up to which Traction Help can be activated

Parameter 35 is not subject to legal provisions.

- Set Parameter 35 to  0 k.p.h.

Parameter 36

Speed at which Traction Help will automatically switch itself off

According to EC Guideline 97/27/EG (2001) this limiting speed  of 30 k.p.h. may not be exceeded.

Parameter 37

Pressure in the Leading Axle's Supporting Bellows when Traction Help is active

Parameter 37 defines the pressure in the supporting bellows of the leading axle which may not be exceeded when traction help is active.

- Usually a value of 130% of Parameter 28 is set, provided the axle manufacturer has not stipulated a lower value for the maximum load.

 Section 5.2.2 "Control Traction Help" provides more detailed information.

Input is provided in steps, depending on the type of pressure sensor used, of 1/16 (standard value) or 1/20 bar per count.

If the pressure for which the parameter is being set here would be exceeded when the lifting axle is fully raised, the lifting axle will stay on the ground.

The pressure in the supporting bellows of the leading axle is controlled in such a way that it does not exceed the value set by this Parameter. This means that the maximum weight is applied to the driving axle of the motor vehicle. Any load in excess of this is taken up by the partially evacuated supporting bellows for the lifting axle. The axle load is being distributed.

According to EC Guideline 97/27/EG (2001) the axle load may not be exceeded by more than 30% in the member states of the EU. Provided that the value is not exceeded.

$$P_{\text{Bellows Laden}} [\text{bar}] + 30\% \cdot 16 [\text{counts/bar}] = \text{Input Values} [\text{counts}]$$

Parameter 38

Pressure Hysteresis for Axle Load Distribution while Traction Help is active

While traction help control is active, the distribution of the axle load across the lifting axle and the leading axle causes the pressure in the leading axle's supporting bellows to rise.

This pressure in the leading axle's supporting bellows is kept below the pressure defined in Parameter 37 by defining a tolerance range in Parameter 38. Input is provided in steps, depending on the type of pressure sensor used, of 1/16 (standard value) or 1/20 bar per count.

- Set Parameter 38 to  4 counts.

Parameter 39

Increasing the Driving Level when Lifting Axle is raised (Lifting Axle Offset)

Parameter 39 specifies the value for increasing the driving level when the lifting axle is raised. This achieves improved clearance for the wheels of the lifting axle. This effect is also called "zero point offset". The value set for this parameter is important for the calibration process because it then raises only the driving level of an unladen or partially laden vehicle.

 Parameter 19 only applies to the lowest existing driving level (standard setting up to Version 4) or for Driving Levels I and II. Parameter 19 does not apply for Driving Level III.

The decision about the setting for this is made in Parameter 4, Bit 3.

-  Set input value for Parameter 39 different from Parameter 23/24 (in counts).

Parameter 40

Delay Plausibility Error Detection

Parameter 40 indicates a time after the ignition is switched ON in which the ECU does not check the system for plausibility errors.

Plausibility errors are caused by values provided by the height sensors which are different from those expected by the ECU.

The ECU checks the way ECAS reacts to any commands given. For example, after a command to RAISE has been given, the ECU expects a rising number of counts supplied by the height sensors. If the counts remain unchanged, or if they even fall, the ECU considers this to be implausible. The ECU detects a so-called plausibility error. In spite of ECU working properly, a raise command can sometimes not be executed, especially when the vehicle has not been moved for some time, due to a shortage of compressed air in the air suspension system. To prevent an error being recorded due to this shortage, Parameter 40 is used to give the air suspension system enough time to build up sufficient operating pressure to execute the raise command.

Input is provided in steps of 10 seconds.

- Set Parameter 40 to  120 counts.

Parameter 41

Limiting Speed above which the Driving Level is activated automatically

Parameter 41 defines a speed above which the current driving level is automatically addressed. The driving level assumed to be the current driving level depends on:

- the position of the driving level switch or the driving level preselected from the remote control unit
- the setting for speed-related levelling control (↑ see Parameters 25 and 26).

Parameter 41 is important for vehicles which:

- do not use a remote control unit,
- on which the CLOCK and DATA lines on Connector X2 of the ECU have not been bridged.

In this vehicles is not automatically addressed when the ignition is switched ON.

Parameter 41 is of major importance for semi-trailers being attached to or detached from the tractor, or for trailers with interchangeable platforms. For these, a speed should be set which is high enough to prevent the driving level being addressed automatically at slow speeds.

! Only values greater than 3 are recommended. Inputting a value of 255 deactivates this function.

- Set Parameter 41 to  20 k.p.h.

If the Parameter is set to 0 the driving level will be adjusted at speed. All further controls are possible in standstill.

Parameter 42

Pressure on the Leading Axle at which Compensating for Tyre Deflection begins

Parameter 42 defines the pressure in the supporting bellows of the leading axle at which the system begins to compensate for tyre deflection.

- Preferable the supporting bellows pressure for the unladen vehicle should be selected.

Input is provided in steps, depending on the type of pressure sensor used, of 1/16 (standard value) or 1/20 bar per count.

 $p_{\text{Bellows Empty}} [\text{bar}] + 0,5 [\text{bar}] \cdot 16 [\text{counts/bar}] = \text{input values} [\text{counts}]$

Parameter 43

Pressure on the Leading Axle at which Compensating for Tyre Deflection ends

Parameter 43 defines the pressure in the supporting bellows of the leading axle at which the process to compensate for tyre deflection ends.

- Preferable the supporting bellows pressure for the fully laden vehicle should be selected.

Input is provided in steps, depending on the type of pressure sensor used, of 1/16 (standard value) or 1/20 bar per count.

 $p_{\text{Bellows Laden}} [\text{bar}] \cdot 16 [\text{counts/bar}] = \text{Input Values} [\text{counts}]$

Parameter 44

Maximum Offset for Compensating for Tyre Deflection

Parameter 44 is used to define the amount by which a tyre is compressed, i.e. deflection between the load conditions.

The load conditions are defined by Parameter 42 and 43.

- This value should be determined by tests done on the vehicle.

The vehicle established then applies only to the tyre used with the applicable axle steering kinematics.

If tyres other than the ones from the test are used with this parameter setting, unintentional changes in the level might result. This changes in the level could in turn cause the permissible height of the vehicle to be exceeded.

- For standard trailer tyres and standard height sensor levers set Parameter 44 to a value  between 15 and 20 counts.

Parameter 45

Pressure on the Leading Axle at which both Lifting Axle may be raised

(only applies to systems with two separate lifting axles)

Parameter 45 provides the pressure in the supporting bellows at which, in a system with two separate lifting axles, both can be raised simultaneously. This may be necessary when both lifting axles of an unladen vehicle are to be raised, e.g. after the ignition has been switched on.

Parameter 45 is effective only in systems with two separate lifting axles. Whether this is the case is determined by Parameter 2, Bit 6.

The pressure for which this parameter is being set corresponds to a pressure $p_{\text{LA1+2Raise}}$ from section 5.2.3 "Control Algorithm for Lifting Axle Control (two separate Lifting Axles)". That section also describes in detail how this pressure is determined. Apart from the unladen bellows pressure, this is the lowest pressure setting for which a parameter is being set for lifting axle control.

! The following applies:
 $p_{\text{Empty}} < \text{Parameter 45} < \text{Parameter 46}$

Input is provided in steps, depending on the type of pressure sensor used, of 1/16 (standard value) or 1/20 bar per count.

 $\frac{p_{\text{Bellow Laden}} [\text{bar}] \cdot 0.8 \cdot A}{\text{Total Number of Axles}} \cdot 16 [\text{counts/bar}] = E$

E = Input Values [counts]
 A = Number of Non-Liftable Axles

Parameter 46

Pressure on the Leading Axle at which the 2nd lifting Axle may be raised (Only applies to Systems with two separate Lifting Axles)

Parameter 46 provides the pressure in the supporting bellows at which, in a system with two separate lifting axles, the 2nd lifting axle is raised. If the limiting pressure defined in Parameter 46 is not reached in spite of the load on the 2nd lifting axle / trailing axle being reduced, the 1st lifting axle is raised / the weight on the trailing axle is reduced after a delay of 15 seconds.

 Parameter 46 is effective only in systems with two separate lifting axles.

Whether this is the case is determined by Parameter 2, Bit 6. The pressure for which this parameter is being set corresponds to a pressure $p_{LA2\ Raise}$ from section 5.2.3 "Control Algorithm for Lifting Axle Control (two separate Lifting Axles)". Section 5.2.3 describes in detail how this pressure is determined.

 The following applies:
Parameter 45 < Parameter 46 < Parameter 29

Input is provided in steps, depending on the type of pressure sensor used, of 1/16 (standard value) or 1/20 bar per count.

$$P_{\text{Bellow Parameter 46}} [\text{bar}] + 0,5 [\text{bar}] \cdot 16 [\text{counts/bar}] = \text{Input Values} [\text{counts}]$$

Parameter 47

Follow-Up Time when Unloading Level is being active and Ignition is switched off

– Parameter 47 can be used to set up a follow-up time after the ignition has been switched off.

This follow-up time only being active while the unloading level has been activated (Parameter 4/5 or 5/6, depending on the type of ECU used).

– The superstructure is in contact with its upper stop (calibration level) when the ignition is switched off.

ECAS will use the voltage supply from Terminal 30 to lower the superstructure to the upper stop level.

Calibration Level - Reference Value Tolerance - 3 counts = Upper Stop Level

This means that the bellows are evacuated to a point where there is no longer any weight resting on the shock absorber stop.

This function is useful when a vehicle has just been un-

loaded very suddenly and rapidly (e.g. dumping a load from a tipper body).

ECAS requires a certain time for readdressing the defined unloading level.

- Therefore, the supporting bellows whose pressure was at the "laden" level would normally press the superstructure against the rebound straps.

or

- In the absence of any rebound straps, the oscillation dampers apart as far as possible, thus causing an excessive tensile load.

The result would be that ECAS would have to evacuate the supporting bellows down to a level where the unladen level is addressed. If the ignition is then switched off at that point (e.g. The driver leaves his cab to make sure that the load really has been dumped completely from the tipper body.) ECAS would abort the control process.

Due to the absence of any ignition current, the superstructure would remain in its upper position for some time, and the strain on the buffers, or stops, could be excessive.

The same excessive strain could occur if the ignition of a tanker truck using ECAS is switched off while it is being unloaded by an external pump.

Again, the buffers can be protected from excessive strain by setting Parameter 47 accordingly, provided the unloading level (Parameter 3 Bit 5) has been set.

Input is provided in steps of 10 seconds.

– Set Parameter 47 to  30 counts.

Parameter 48

Time Period for Stand-By Operation

– Set time for time period for which stand-by operation in counts.

Input is provided in steps of 15 minutes. The highest possible setting is stand-by operation for more than 63 hours.

– Set Parameter 48 to  48 counts (equals 12 hours).

Parameter 49

Increased Tolerance in Stand-By Operation

Parameter 49 is used to define the permissible amount by which the reference value defined in Parameter 9/10 can be exceeded in stand-by operation.

If a raising operation is performed in stand-by operation:

- The amount of control work can be reduced.
- The accuracy of the setting range is impaired.

The tolerance for the reference values defined in Parameter 9/10 continues to apply. This allows a setting which reduces air consumption to a minimum.

- It is advisable to increase the tolerance range of Parameter 49 to  10 to 20 counts or to double Parameter 9/10.

Parameter 50

Time Period for Detecting Plausibility Errors

Parameter 50 defines a period of time. In this period the ECU expects a command to be executed or continued. If command given is not followed by any reaction, the ECU detects implausible behaviour ("Delay plausibility error detection"  Parameter 40).

Input is provided in steps of 0.3 seconds.

- Set Parameter 50 to a periode of 30 seconds, equalling  100 counts (standard setting)

Parameter 51

Driving Speed above which the Lifting Axle(s) is (are) raised if Fully Automatic Lifting Axle Operation is in Place

(from Software 9.1.1.D Upwards)

- Set Parameter 4 Bit 2 = 1.

The lifting axle (s) is (are) then not raised immediately after the ignition is switched on but only when a certain speed is exceeded.

The ECU is informed of this speed by Parameter 51.

- Set Parameter 51 to 0 k.p.h., this causes the lifting axle(s) to be raised while the vehicle is stationary.
- Set Parameter 51 between 10 and  20 k.p.h.

Around 20 k.p.h. the tyre speed is sufficient to remove any dirt which might adhere to them. If a value higher than 30 k.p.h. is entered, this is set back to 30 by the ECU.

On vehicles with two separately controlled lifting axles: Input Value Parameter 51 \geq Input Value Parameter 31

This would cause the 2nd lifting axle to be raised too, after traction help has been active, and not when the vehicle has subsequently been stopped.

After unloading, the lifting axle will also not be raised until the value set in Parameter 51 has been exceeded.

Parameter 52

Increasing the Level if Traction Help is active (from Software 9.1.1.D Upwards)

If traction help is active, the level is raised by the value defined in Parameter 52

-  Input Value \geq Parameter 39
- Input Value between 10 and 20 counts (for tippers).

9.3 The Calibrating Process

 As part of the commissioning procedure of a new vehicle, the sensors have to be calibrated after the parameters have been set.

The height and pressure sensors which are part of the system have to be "introduced" to the ECU. This means that a reference value for the ECU has to be defined.

The calibration process has to be repeated every time the ECU is to work with a new sensor. This also applies when:

- a sensor has been replaced,
- the ECU has been replaced.

Depending on the type of sensor to be calibrated, we distinguish between:

- Height Sensor Calibration,
- Pressure Sensor Calibration.

9.3.1 Height Sensor Calibration

The process of calibrating the height sensor means that the height sensor is adjusted to the ECU. Usually the vehicle's superstructure is taken to Driving Level I, its upper level and its lower level. The ECU is then informed of the individual levels. Upper and lower level refer to the stops which cannot be exceeded within the raising and lowering processes.

- When an ECAS system is first commissioned, each of the system's height sensors should be calibrated separately.
- The values for the height sensors are entered in counts.

Proper calibration requires the following tasks to be done scrupulously:

- Place vehicle on a surface which is horizontal and even.

- Make sure that the height sensor has been properly installed and that its lever can move freely across the whole of the raising/lowering range.
- If the vehicle has two height sensors on one axle, the bellows on both sides are connected to each other by means of a test hose. This causes the pressure to spread the load evenly across the axle.
- Determine the distance between the vehicle's superstructure and the axle for each height sensor, at least in Driving Level I.
- Do not brake vehicle (secure against rolling away).
- Ensure that a sufficient air supply is available.

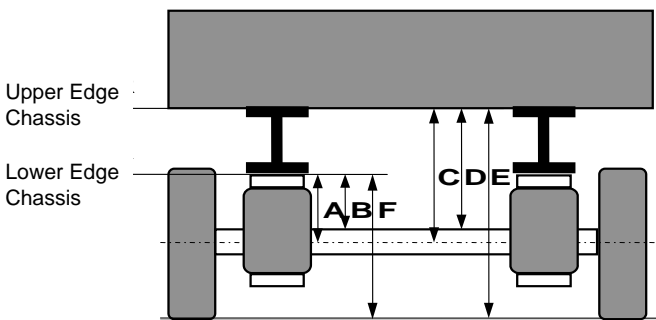

Fig. 39 Dimensions for Height Sensor Calibration - Overview

- A Distance between lower edge of side member and centre of axle beam
- B Distance between lower edge of side member and upper side of axle beam
- C Distance between lower edge of superstructure and centre of axle beam
- D Distance between lower edge of superstructure and upper side of axle beam
- E Distance between lower edge of superstructure and road surface
- F Distance between lower edge of side member and road surface

For a uniform documentation standard measuring points are defined according to the shown survey of reference dimensions.

- Wherever possible, calibration levels should be entered as defined by the axle manufacturer.

Usually this is the distance between the centre of the axle and the lower edge of the side member. (↑ Fig. 39 - Dimension A)

- Any indication of the dimension measured must always include the appropriate code letter because otherwise it is impossible to allocate the heights given in millimeters.

erwise it is impossible to allocate the heights given in millimeters.

- Avoid using dimensions E and F wherever possible because any dimensions measured would include the deflection in the tyres.

Depending on the load carried, distortions might result later.

The following basic instructions must be followed for determining calibration levels:

- Measure directly on the axle, not in front of or behind the wheel (when looking in driving direction).
- Measure as close as possible to the air bellow (when looking along the axle).
- Measure on the side where the height sensor is located.
- The calibration level determined should be recorded.

This way they are available when the vehicle goes in for service.

They may also be included when the parameter record is transmitted to WABCO. This would allow WABCO to store the calibration data in its database.

! Only one type of dimensions should be used on vehicles with several axles.

The levels are indicated in the order:

1. Driving Level,
2. Highest Level,
3. Lowest Level.

Example for a complete designation:

Dimension Type A, front 250/390/202, rear left 273/420/210, rear right 275/422/213 (dimensions in mm)

If an ECU is to be replaced and the calibration data for the vehicle are not known:

- The height sensor data calibrated in the ECU to be replaced can be displaced in the PC.
- If this is no longer possible, the following assumptions may be made:
 - In Driving Level I, the height sensor lever is virtually horizontal.
 - The upper and lower levels are addressed until the superstructure can no longer be raised or lowered.
- Calibration of the height sensor is done by using the PC.

9.3.1.1 Height Sensor Calibration with the PC

For calibrating three calibration levels (↑ 9.2.4 Explanation of Parameters - Parameter 1 Bit 6), each of the levels to be calibrated has to be addressed in the following order:

1. Driving Level I
2. Upper Stop Level,
3. Lower Stop Level.

a)

- First the vehicle is taken to the established Driving Level I (for the front axle and the rear axle).
- Then the calibration is initiated.

Actual levels are now being stored as driving level.

b)

- Take the vehicle to its upper stop level.
- Re-initiate the calibration process.

Actual levels are stored as upper stop levels.

To protect the stops, the ECU will automatically reduce the value for the upper stop level by 3 counts.

c)

- Take the vehicle to its lower stop level.
- Re-initiate the calibration process.

Actual levels are stored as lower stop level.

! When using the PC for calibration, the vehicle's levels cannot be changed using the remote control unit. To enable the ECU to recognise the remote control unit, it has to be connected to the system during the calibration process.

After the individual calibration phases are completed, the PC will check the fault memory and display whether calibration has been achieved successfully or not.

Basic principles for successful calibration:

- **4 counts < HSV < 255 counts**
The height sensor values entered must be greater than 4 counts and smaller than 255 counts.
- **$HSV_{UL} > HSV_{DL} + 3 \text{ counts} + 3 \times \text{Parameter 9/10}$**
The upper stop level $_{UL}$ must be larger than the total of driving level $_{DL}$ plus 3 counts and reference value tolerance multiplied by three. The reference value tolerance is defined in Parameter 9 (for the 'front') and Parameter 10 (for the 'rear'). The front/rear assignment of the height sensor depends on its slot in the control unit.

- **$HSV_{UL} < HSV_{DL} \cdot 2 \times \text{Parameter 9/10}$**

The lower stop level $_{LL}$ must be smaller than the driving level $_{DL}$ minus the reference level tolerance multiplied by two.

To calibrate a Driving Level and to enter the Upper and Lower Stop Levels manually

This may be done if the superstructure is to move all the way to the stops. It helps to avoid a stop release in the upper level.

! Follow the basic principles for a successful calibration.

Starting from the normal level rear left and rear right, the calibration values for the "upper/lower stop level rear" can be defined as follows:

- 1. Calculate the differences between:
 - Upper Stop Level Rear Left - "Normal Level Rear Left"
 - Upper Stop Level Rear Right - Normal Level Rear Right
- 2. Calculate the sum of:
Smaller Difference (Result 1.)+
Expected Calibration Value "Normal Level Rear Left"
= Calibration Value to be entered "Upper Stop Level Rear".
- 3. Calculate the differences between:
 - Driving Level Rear Left - Lower Stop Level Rear Left
 - Driving Level Rear Right - Lower Stop Level Rear Right
- 4. Calculate the difference between:
Expected Calibration Value "Normal Level Rear Left"
- Smaller Difference (Result 3.) = Calibration Value to be entered "Lower Stop Level Rear"
- Before calibrating store the computed data in the PC.

Initiate the calibration process as follows:

- Take vehicle to its driving level.

By initiating the calibration process, this level is recognised as the driving level.

After the individual calibration phases are completed, the PC will check the fault memory and display whether calibration has been achieved successfully or not.

Calibration by entering actual Height Sensor Values

! Entering the height sensor values can only be done after entering a PIN. To do this, the height sensor values have to be known. The direct input is done with the PC diagnostic program under system/calibration data height sensors.

! During calibration mind the increased normal level when the lifting axle is raised and the compensating for tyre deflection (↑ 9.2.4 Explanation of the Parameters - Parameter 44).

The function "increased driving level with raised lifting axle" and the compensating for tyre deflection (↑ 9.2.4 Explanation of the Parameters - Parameter 44) is suppressed during the calibration.

This means that it is not necessary to calculate a possible increase of the level due to a raised lifting axle or tyre deflection.

If ECAS is, after calibration, in operation mode and the command "driving level" is given, Parameters 39 and 44 are taken into account while the driving level is being addressed.

It might occur that a different driving level than the one calibrated is addressed.

9.3.2 Pressure Sensor Calibration

The process of pressure sensor calibration means that the pressure sensor is adjusted to the ECU.

- The values for the pressure sensors are entered in counts.

! From ECU software version 9.1.1D onwards, pressure sensors are no longer need to be calibrated.

Pressure sensor calibration is in fact an offset allocation. I.e. at ambient pressure the pressure sensor transmits a certain signal to the ECU. Depending on the type of sensor used, the signal is somewhere around 16 or 20 counts. This value has a pressure of 0 bar allocated.

Proper calibration requires the supporting bellows to which the pressure sensor has been attached to have atmospheric pressure.

- In order to achieve this, the bellows are evacuated until no evacuation noise can be heard.

The vehicle will now be resting on its buffers.

- Compress the bellows manually.
- Calibration of the height sensor is done by using the PC.

! Calibration can also be done without PC. This should be done in emergencies only because this involves a complex procedure which has to be followed scrupulously. For further information, please contact your WABCO partner.

When the parameters have been set and the calibration process has been completed, the vehicle has been commissioned.

- Exit from the diagnostic programme.
- It might be advisable to read out the error memory first.

The vehicle is now ready for operation.

10. Troubleshooting

10.1 Safety Concept

In order to check the functioning of ECAS, the ECU:

- Testing the electrical connections to the individual components for the various control processes,
- Compares the voltages and resistance values to the reference values,
- Checking the sensor signals for plausibility.

 The check cannot be done at the input ports on the ECU (Connectors X7, X8, X9, X10 and X15).

 Connect a signal lamp (24 V, 5 W) to Connector X6 of the ECU to enable the driver check the state of the ECAS system.

Every time the ignition is switched on, the lamps will come on for a few seconds as a function check.

The signal lamp can indicate three conditions if ignition is switched ON:

Signal Lamp OFF

- The system is functioning properly.
- The vehicle is now ready to be driven.
- There is currently no error.

Signal Lamp ON

- The system is functioning properly.
- The vehicle is now ready to be driven but is outside a driving level.
- There is currently no error.

Various meanings of signal lamp ON

- Functional test of the signal lamp after the ignition has been switched on. (The lamp comes on for a few seconds as a function check.)
- Traction help facility is activated.
- "Automatic-lowering" function has been activated.
- "Unloading Level" function has been activated.
- Automatic lifting axle operation has been switched off from remote control unit using the "lower lifting axle" command (applies only for ECU variant 446 055 060/070 0).

Signal Lamp flashing

- There is an error within the system.
- The vehicle might still be drivable to some extent.

 The flashing light has priority over continuous light.

ECAS Reactions depending on the Type and Significancy of the Error

- If the error is minor or if the voltage supply is insufficient (voltage between 5 and 18 volts):
No further reaction
- If there are plausibility errors or while the system is in diagnostic mode:
The system is temporarily switched off.
- If the error is severe: The system is switched off.

The severity and characteristics of a error are described as follows:

Minor Errors

- Failure of a height sensor if the same axle has another height sensor.
- Failure of one pressure sensor.
- Failure of both pressure sensors (only possible if ECU variant 446 055 060 0 is used).
- Error in the data stored in the ECU.

The System reacts as follows:

- The signal lamp is flashing.
- The error is stored in the non-volatile memory of the ECU.

Minor errors permit a limited function of the ECAS system. The system will not be switched off. After the error has been solved, the system will go back to normal operation.

Plausibility Error

A plausibility error cause the system to be switched off temporarily.

Due to the absence of measuring sensors on the inlet or outlet ports of the solenoid valves, the ECU can not measure any error. It can conclude that there is a (plausibility) error on the basis of the signals received from the height sensors which are implausible.

For this, the ECU must fail to recognise any reaction to a control process which has been initiated for addressing a reference level, within a period defined in Parameter 50 (standard: 30 seconds). At the same time, the delay defined in Parameter 40 for indicating any error must be exceeded.

Malfunctions which can cause a Plausibility Error to be reported:

- The ECAS solenoid valve is failing to pressurise or evacuate the supporting bellows.
- The ECAS solenoid valve is remaining in its pressurising or evacuating position although the control process has been ended.
- Defect in the supply of compressed air e.g. blocked or bent lines, insufficient supply pressure.
- Leakage in the supporting bellows.

Reaction of the System to Plausibility Errors:

- The signal lamp is flashing.
- The failure is stored in the non-volatile memory of the ECU.
- The current control process and levelling control are aborted.

Solving brief error in operation or errors which merely seem to exist:

- Switching the ignition off and on again.

or

- Pushing one of the buttons on the remote control unit.

If the error does not turn up again, the system is operating as usual. The error will, however, continue to be stored in the ECU until it is deleted.

Severe Errors

Severe error cause the system to be switched off permanently. They are divided into two categories.

Category I

ECAS can no longer execute any functions.

Category I includes these errors:

- An error has been detected in the programme of the ECU (ROM module).
- A storage cell in the ECU's main memory (RAM) is defective.
- A valve relay is interrupted (no contact from Terminal 30) or has a short circuit/ an external voltage at the valve-outlet port.

Category II

Emergency operation is possible via the remote control unit. Axle preselection will definitely be working. Raising/lowering by pushing RAISE/LOWER button providing air supply for raising/lowering. Category II includes these errors:

- Parameter error:
The check total of the parameter values has changed or the parameters have not been set on the ECU.

- Calibration error:
 - The calibrated sensor values are outside their permissible tolerance.
 - The storage of calibration data is defective (check total has changed).
 - No calibration has been done so far.
- Interrupt or short circuit on a solenoid valve or in a cable leading to the solenoid valve (ECAS or load sensing solenoid valve).
- Failure of all height sensors on one axle.
- Standard value for height sensor evaluation circuit or its check sum faulty or non-existent.
- WABCO-specific data are faulty.

The System reacts to Severe Errors as follows:

- The signal lamp is flashing.
- The failure is stored in the non-volatile memory of the ECU.
- The whole of the system is automatically shut down.



If these errors cannot be put right, the ECU has to be replaced.

Startup of the ECAS system after solving the error of Category II:

- Switch the ignition off and on again.

After replacing the ECU or solving the error it will be stored in the ECU until it is deleted.

Reactions of the System to Intermittent Contact

If an error is temporary, e.g. caused by intermittent contact, it will be displayed, or the system switched off, only as long as the error prevails. The type of error is irrelevant. However, the error will be stored in the error memory so it can be localised in subsequent repairs.

The error will, however, continue to be stored in the ECU until it is deleted.

Errors not perceived by the ECU

- **A Burnt Filament of the Signal Lamp**



It is up to the driver to check that the lamp is working when he switches the ignition on.



Spare bulbs are available from the spare trade and are not supplied by WABCO.

- **Malfunction of the Remote Control Unit**

The remote control unit does not transmit signals continuously and it may also be disconnected at times.

The ECU cannot check the function of the remote control unit.

Usually a malfunctioning remote control unit does not represent much of a hazard because the person using it will notice immediately that there is an error.

- **Bent Linkage on a Height Sensor**

A bent linkage can lead to an inaccurate driving level or in a slant of the vehicle.

- **Failure of a Pressure Switch or an Error of the Pressure Sensor within a Permissible Range**

Valid measured values are still being transmitted. The error causes that the permissible axle load might be exceeded.

This error types can only be found upon a close inspection of the system.

- The vehicle may have to be recalibrated after the error has been solved.



If an error is indicated by a flashing signal lamp, or if the system has been switched off and is not being operated by a storage battery, ECAS is not operable. Loading and unloading will not be accounted for by any control system.

10.2 Troubleshooting table

Table 4 show an overview of errors which may occur, representative of those reported by customers

Table 4: Troubleshooting table

Error Indication	Effect of Error	Possible Cause of Error	Suggested Remedy
ECAS signal lamp OFF. ABS signal lamp OFF. ECAS not working. (ABS supply defective)	ECU does not change the level, no reference level change possible with remote control unit.	ABS supply cable not connected or broken or defective fuse for ABS power supply.	Replace ABS supply cable as required or replace fuse for ABS power supply.
ECAS signal lamp OFF. ABS signal lamp ON. ECAS not working. (ECAS supply defective)	ECU does not change the level, no reference level change possible with remote control unit.	ECAS supply cable not connected or broken or defective fuse for ECAS power supply. ECU defective.	Replace ECAS supply cable as required or replace fuses in the ECAS-ECU or in the supply module of ABS VARIO C-ECU (only ECU variant 060). Replace ECU.
ECAS signal lamp ON after moving OFF with superstructure. Outside the driving level the superstructure does not address driving level at speed greater than Parameter 41.	Vehicle does not address driving level.	No C3 signal (ABS) respectively no speed signal via K-line (EBS).	Check wiring ABS-/EBS-ECAS; check ABS signal lamp for defect. Possible speed sensor error.
ECAS signal lamp is flashing, ECAS is inactive, raise/lower function ("emergency function") possible with remote control unit.	ECAS not working, emergency function maintained.	ECU detects a severe error of Category II (↑ 10.1 Safety Concept).	Read out error memory of ECAS-ECU; replace ECU if required (↑ 10.1 Safety Concept) respectively repair error.
ECAS signal lamp ON after error is eliminated, vehicle addresses Driving Level I.	ECAS signal lamp ON.	Traction help active or automatic lifting axle operation switched OFF (no error - ↑ 10.1 Safety Concept). Unloading level active.	Traction help switches OFF automatically or switch ON lifting axle operation (↑ 8.4 Remote Control Unit). Deactivate unloading level.
ECAS signal lamp does not go OFF after ignition ON.	May be due to slanting vehicle.	Vehicle not in driving level special function is active e.g. unloading level.	Take vehicle to driving level with remote control unit (↑ 8.4 Remote Control Unit) or drive the vehicle at a speed which is faster than that set in Parameter 41. Switch OFF unloading level.
ECAS signal lamp not working after ignition ON, or ECAS signal lamp but ECAS fully operable.	ECAS signal lamp provides no information.	Signal lamp or signal lamp feed line defective.	Signal lamp or signal lamp feed line defective.
Lifting axle is raised only in diagnosis mode but not in ECAS operation.	Lifting axle does not raise if the vehicle is unladen/partially laden.	Automatic lowering is active. Traction help is active permanently.	Deactivate automatic lowering. End traction help (possible wiring error on motor vehicle).

Error Indication	Effect of Error	Possible Cause of Error	Suggested Remedy
Raising of the lifting axle not according to preset pressures but at lower pressures.	Lifting axle 1 raised too soon, lifting axle 2 raised much too late, and both lifting axles together raised only if below pressure is 0 bar.	Defective pressure sensor, wrong parameter.	The pressure sensor value must have been included in the offset. Pressure sensor reports wrong values.
Lifting axle is lowered much too late.	The lifting axle is not lowered at the present pressure point.	Wrong parameter, defective pressure sensor.	Check parameter for lowering (Parameter 28). Check pressure sensor and its wiring (corrosion).
ECAS signal lamp ON; starts to flash after a while.	ECU does not change level.	Plausibility error Wrong parameter Poor evacuation Vehicle distortion	Charge compressed air reservoir; check height sensor for plausible reaction (increasing counts when raising, increase Parameters 40 + 50). Find cause of distortion.
Driving level is raised while lifting axle is being raised.	Vehicle is over the driving level.	No error, driving level is raised according to Parameter 39.	Adjustment of Parameter 39 required if legal maximum heights are exceeded
No switch-over from Driving Level I to Driving Level II when vehicle is unladen and axle is raised.	Driving Level II cannot be adjusted.	Driving Level II lies above Driving Level I (Parameter 24/25), by the difference of the lifting axle "zero offset" (Parameter 39); no error if ECU variant 065/066: wrong parameter setting.	Change Parameter 24/25 and Parameter 39 if necessary. Set Parameter 4 Bit 3 = 1.
Lift axle cannot be raised by remote control unit.	Lifting axle stays on the ground.	Vehicle load too heavy - no error defective remote control unit or defective pressure switch/pressure sensor or wrong parameter setting for lifting axle control.	Unload vehicle or fit a new remote control unit or fit a new pressure switch/pressure sensor or change parameter setting. Increase Parameter 29.
Vehicle superstructure above rear axle is being raised or lowered continuously.	Continuous control, continuous change of driving level.	2/2-way valves of RA valve block stay open. Sensor leap. ECU defective.	Replace solenoid valve block. Check/replace height sensor, replace ECU.
Continuous actuation of ECAS solenoid valves when in motion.	Unchecked raising and lowering of superstructure while vehicle is moving.	No C3 signal (ABS) or no data transmission on the K-line(EBS) or wrong parameter settings for basic function (Parameter 9/10/19/20/21/22).	ECAS solenoid valve leaking or check wiring ABS/EBS-ECAS or check wiring ABS/EBS-ECAS or alter parameter settings
Traction help and lifting axle function cannot be activated.	Lifting axle stays on the ground.	Load does not permit activation or pressure sensor defective or no pressure sensor signal via K-line (EBS).	Check load – no error or replace pressure sensor. Check EBS system, check K-line.
Lifting axle cannot be lowered.	Lifting axle remains raised.	Remote control unit defective or pressure sensor defective or no pressure sensor signals via K-line (EBS). No supply pressure.	Replace remote control unit or replace pressure sensor. Check pressure.
If two height sensors on rear axle, superstructure is slanting.	Slanting superstructure.	Sensor linkage bent or uneven surface - no error. Rubber on linkage has slipped.	Straighten height sensor linkage or check Parameter 11 and adjust as required. Tighten rubber.
Different supporting bellows pressures on one axle.	Slanting superstructure.	Transverse throttle in ECAS solenoid valve (one height sensor) or stabiliser distorted (two height sensors).	Replace ECAS solenoid valve or recalibrate the vehicle. Check stabiliser.

Error Indication	Effect of Error	Possible Cause of Error	Suggested Remedy
After parameters have been set, the remote control unit is not accepted by the ECAS (only if Parameter 1 Bit 7 = 1).	No raising/lowering possible with remote control unit.	Remote control unit not connected to ECAS during calibration.	Recalibrate vehicle while remote control unit is connected.
In spite of operable ABS-/EBS-ECU and ECAS-ECU troubleshooting cannot be initiated with PC.	No troubleshooting possible via PC.	Wrong ISO address setting or diagnostic line/socket defective or measuring value output switched ON.	Set ISO address to 18 or repair diagnostic line or switch OFF output of measured values (set Parameter 2 Bit 7 = 0).
Reference level cannot be changed by remote control unit.	No change in reference level.	No axle preselected on remote control unit or ignition OFF or if several remote control units: Changeover switch is in wrong position or remote control unit is defective.	Preselect axle or ignition ON or put changeover switch into correct position or replace remote control unit.
No reaction of ECAS solenoid valves while loading/unloading.	No levelling control.	ECAS switched or setting for Parameter 16 is excessive or excessive reference value tolerances (Parameter 9/10).	Switch ON ECAS - select Stand-by function (↑ 8.4 Remote Control Unit) or reduce setting for Parameter 16 or adjust Parameter 9/10.
ECAS-ECU cannot have parameters set or be calibrated.	No reaction of the ECAS-ECU.	ECU defective. Water in the ECU.	Replace ECU. Remedy the cause for water.
Lifting axle is swinging (raising/lowering).	Lifting axle does not remain in allocated position.	Parameter setting for Parameter 28/29 in unfortunate. Pressure sensor/cable defective.	Increase difference between parameters (pressure difference) Check, replace as necessary.
Lifting axle is raised in full load.	Lifting axle stays raised although full load is assumed.	No error as the load does not achieve the pressure applicable to the maximum axle load.	Improve information for customers. Reduce Parameters 28/29.

11. Replacing Components

11.1 Replacing ECU

Since the end of 1998, only the new ECU variants 446 055 065/066 0 have been available. Their predecessors 446 055 060/070 0 are no longer being sold (↑ 8.2 Electronic Control Unit (ECU) 446 055 ... 0).

The ECU variant 446 055 065 0 has replaced ECU variants 446 055 060/070 0. In this case the old set of parameters have to be adjusted to the new ECU. The following must be observed:

- The new ECU needs 52 parameters to be set instead of 47 parameter previously.
- Compared to the previous ECU, factors have been changed in these parameters (e.g. "permanent traction help" in steps of 5 seconds and not of 1 second as before).

- In systems for which parameters have been set for pressure sensors, the new ECU is designed to work with pressure sensor 441 040 007 0 (pressure/counts ratio: 1/16 bar) ausgelegt, die alte ECU für den Drucksensor 441 040 003 0 (Druck/counts-Verhältnis: 1/20 bar).

Various Types of replacing the ECU:

Type 1

ECU variant 446 055 060 0 needs to be replaced by ECU variant 446 055 065 0, while the pressure sensor remains in the vehicle, or there is no pressure sensor.

- Copy parameter record from the old ECU to the PC.
- After replacing the ECU, this parameter record is then copied into the newly installed ECU.

The parameter record is automatically converted when this is being done, i.e. the older parameter set is adjusted to the new ECU.

The number of parameters is extended automatically and set if required. The time factors (e.g. times required in the context "traction help") are also adjusted for the new ECU.

- Those parameters defining pressure values have to be adjusted, i.e. reset to their original values.

Only applies if the system includes a pressure sensor.

Type 2

In a vehicle or vehicle type ECU variant 446 055 060 0 and pressure sensor 441 040 003 0 are replaced by ECU variant 446 055 065 0 and pressure sensor 441 040 007 0.

- Copy parameter record from the old ECU to the PC.
- After replacing the ECU, this parameter record is then copied into the newly installed ECU.

The parameter record is automatically converted when this is being done, i.e. the older parameter set is adjusted to the new ECU.

The number of parameters is extended automatically and set if required. The time factors and pressures for the new pressure sensors are adjusted to the new ECU.

Type 3

ECU variant 446 055 060 0 needs to be replaced by ECU variant 446 055 065 0, while the pressure sensor remains in the vehicle, or there is no pressure sensor.

The parameter record is only available on paper.

- Rewrite the parameter record before entering in the ECU.

Mind the following rules:

- Parameter 0 to 3 are to be copied.
- Parameter 4 should be set to 0 count.
- Parameters 5 to 18 have the parameter numbers of the previous ECU minus ONE allocated.

This means:

Parameter 5 was Parameter 4, ...

Parameter 18 was Parameter 17.

The parameter values themselves will they be identical.

Parameter 19 to 47 can basically be left as they are, needing the following modifications:

- Set Parameter 27 to 240 counts.
- Be aware that parameter values of Parameter 32, 33, 34 and 47 are now only ONE FIFTH of the previous parameter values.
- Set Parameter 48, 49 and 52 to 0 count.
- Set Parameter 50 to 100 counts.

Type 4

In a vehicle or vehicle type ECU variant 446 055 060 0 and pressure sensor 441 040 003 0 are replaced by ECU variant 446 055 065 0 and pressure sensor 441 040 007 0.

The parameter record is only available on paper.

- Rewrite the parameter record before entering in the ECU.

Mind the following rules:

- Parameter 0 to 3 are to be copied.
- Parameter 4 should be set to 0 count.
- Parameters 5 to 18 have the parameter numbers of the previous ECU minus ONE allocated.

This means:

Parameter 5 was Parameter 4,

Parameter 6 was Parameter 5,

Parameter 7 was Parameter 6, ...

Parameter 18 was Parameter 17.

The parameter values themselves will they be identical.

Parameter 19 to 47 can basically be left as they are, needing the following modifications:

- Set Parameter 27 to 240 counts.
- Be aware that parameter values of Parameter 32, 33, 34 and 47 are now only ONE FIFTH of the previous parameter values.
- The new parameter values for Parameters 28, 29, 30, 37, 38, 42, 43, 45 and 46 are FOUR FIFTH of the old parameter values.
- Set Parameter 48, 49 and 52 to 0 count.
- Set Parameter 50 to 100 counts.



For replacing ECU variant 446 055 070 0 by ECU variant 446 055 065 0 the same rules apply.

11.2 Replacement of the Power Supply Module

Replacing ECU variant 446 055 060/070 0 by a new ECU brings up the question of what should happen with the supply module in the lower part of the housing. The easiest and quickest solution is to keep the module.

- Connect the lines coming from the supply module with the new ECU.

A storage battery installed can be supplied directly via Output X4 of the new ECU. The pressure sensor is connected to Output X5 of the new ECU. If the supply module is also defective, replacement is recommended.

! A switch which is connected to Output X8 of the old ECU no longer receives any ground in the new ECU. This output is used as L-line ABS and supplies no longer the ground. Therefore the ground has to be trapped from another connector.

11.3 Replacing Components

The system of electrical connections has been standardised with DIN 72585 ("DIN-bayonet").

The new generation of solenoid valves, pressure sensors, and height sensors with their corresponding sockets are developed for the use on trailers. This includes modified connecting cable with equipment plugs to match. Since the introduction of ECU variant 446 055 065/066 0 these components are used on new trailers.

The old ECAS solenoid valves with a coupling ring with a thread M 27x1 or "Schlemmer Bayonet" are still being made for the spare parts market. However, when the production of these spare parts runs out the workshop will be facing problems using ECAS component with DIN bayonet.

Table 5-7 show ECAS components which perform similar functions. They also include more information on where they are used, the electrical interface, cable required including in the connectors to be assigned on the ECU, cable colours, etc. This allows a component with "DIN bayonet" being installed in an existing system. In this case the corresponding cable needs to be replaced as well.

Table 5: Pressure sensor 441 040 00. 0

ECAS System (Used ECU Variant 446 055 ... 0)	Pressure Sensor used	Pressure Steps of Sensor for 1 count	Comments on Pressure Sensor	Interface Cable/Pressure Sensor	Cable used	Cable Dimension (no. of Wires x area x length)	Wire Colours	Connector on the ECU (Con. = Connector)
"Classical" Version (Variant 060)	441 040 003 0	Original Sensor Type	1/20 bar	Schlemmer Bayonet	894 604 419 2 (3-Pin)	3 x 1 ² x 6000	PIN1: grey/red PIN2: brown PIN3: open PIN4: white	1. Con. 5/15 2. Con. 5/31 3. open 4. Con. 5/DSENS
Revised Version with new Pressure Sensor (ECU Variant 060)	441 040 007 0	Revised Sensor Type	1/16 bar	Bayonet Connection to DIN 72585	449 422 050 0 (4-Pin)	4 x 1 ² x 5000	PIN1: yellow PIN2: red PIN3: green PIN4: brown	1. Con. 5/15 2. Con. 5/31 3. Con. 5/DSENS 4. Ground (Con.8)
Version for VCS with Introduction of Kit (ECU Variant 065)	441 040 007 0	Revised Sensor Type	1/16 bar	Bayonet Connection to DIN 72585	449 732 060 0 (3-Pin)	3 x 0,5 ² x 6000	PIN1: red PIN2: brown PIN3: white PIN4: open	1. Con. 5/15 2. Con. 5/31 3. Con. 5/PSENS
Version for EBS with Introduction of Kit (ECU Variant 066)		Sensor Values only from EBS						

List of Abbreviations for Table 6: Solenoid Valve of Series 472 900 ...0 and 472 905 ... 0

Abbreviation	Acceptation	Abbreviation	Acceptation	Abbreviation	Acceptation
PV	Pressurise/Venting	SV-FA	Solenoid Valve Front Axle	bl	blue
PV-SV	Pressurise/Venting Solenoid Valve	SV-l.Bell.	Solenoid Valve Left Bellow	gr	green
RA-Block	Rear Axle Block	SV-r.Bell.	Solenoid Valve Right Bellow	ye	yellow
LA-Block	Lifting Axle Block	SV-LLA	Solenoid Valve - Lower Lifting Axles	re	red
RR	Rear Right	SV-RLA	Solenoid Valve - Raise Lifting Axles	bl	black
RL	Rear Left			br	brown

Table 6: Solenoid Valve of Series 472 900 ... 0 and 472 905 ... 0

Solenoid Valve	Cable
<p>Front Axle Control New Part: 472 900 058 0 Bayonet Connection to DIN 72585</p> <p>Spare Part: 472 900 021 0 Coupling Ring with Thread M 27x1</p>	<p>1x 449 742 100 0 (2-Pin) 2 x 0.75² x 10000</p> <p>Cable1 (PIN1: bl, PIN2: br): 1. Ground 2. Connection 16 SV-FA</p> <p>1x 894 604 215 2 (2-Pin) 2 x 1.5² x 5000</p> <p>Cable1 (PIN1: br, PIN2: bl): 1. Ground 2. Connection 16 SV-FA (Cable to PV-SV)</p>
<p>Rear Axle 1-Point Control New Part: 472 900 055 0 Bayonet Connection to DIN 72585</p> <p>Spare Part: 472 900 030 0 Coupling Ring with Thread M 27x1</p>	<p>1x 449 422 050 0 (4-Pin) 4 x 1² x 5000</p> <p>Cable1 (PIN1: ye, PIN2: re, PIN3: gr, PIN4: br): 1. Connection 11 PV 2. Ground 3. Connection 11 RL 4. Ground</p> <p>1x 894 604 215 2 (2-Pin) 2 x 1.5² x 5000</p> <p>Cable1 (PIN1: br, PIN2: bl): 1. Ground 2. Connection 11 PV (cable to PV-SV)</p> <p>Cable2 (PIN1: br, PIN2: bl): 1. Ground 2. Connection 11 RL (Cable to SV-l.Bell.)</p>
<p>Rear Axle 2-Point Control New Part: 472 900 053 0 Bayonet Connection to DIN 72585</p> <p>Spare part: 472 900 001 0 Coupling Ring with Thread M 27x1</p>	<p>1x 449 422 050 0 (4-Pin) 4 x 1² x 5000</p> <p>Cable1 (PIN1: ye, PIN2: re, PIN3: gr, PIN4: br): 1. Connection 11 PV 2. Connection 11 RR 3. Connection 11 RL 4. Ground</p> <p>1x 894 604 215 2 (2-Pin) 2 x 1.5² x 5000</p> <p>Cable1 (PIN1: br, PIN2: bl): 1. Ground 2. Connection 11 PV (Cable to PV-SV)</p> <p>Cable2 (PIN1: br, PIN2: bl): 1. Ground 2. Connection 11 RL (Cable to SV-l.Bell.)</p> <p>Cable3 (PIN1: br, PIN2: bl): 1. Ground 2. Connection 11 RR (Cable to SV-l.Bell.)</p>
<p>Rear Axle/Lifting Axle 1-Point Control New Part: 472 905 114 0 Bayonet Connection to DIN 72585</p>	<p>2x 449 422 050 0 (4-Pin) 4 x 1² x 5000</p> <p>Cable1: (PIN1: ye, PIN2: re, PIN3: gr, PIN4: br) 1. Connection 11 RL 2. Connection 11 RR 3. Connection 11 PV 4. Ground (Cable to RA Block)</p>

Solenoid Valve	Cable
Spare part: 472 905 109 0 Schlemmer Bayonet	Cable2 (PIN1: ye, PIN2: re, PIN3: gr, PIN4: br): 1. Connection 19 SV-LLA 2. Ground 3. Connection 20 SV-RLA 4. Ground (Cable to LA Block) Cable1 (PIN1: re, PIN2: gr, PIN3: ye, PIN4: br): 1. Ground 2. Connection 11 PV 3. Connection 11 RL 4. Ground (Cable to RA Block) Cable2 (PIN1: re, PIN2: gr, PIN3: ye, PIN4: br): 1. Ground 2. Connection 19 SV-LLA 3. Connection 20 SV-RLA 4. Ground (Cable to LA Block)
Rear Axle/Lifting Axle 2-Point Control New Part: 472 905 111 0 Bayonet Connection to DIN 72585	Cable1 (PIN1: ye, PIN2: re, PIN3: gr, PIN4: br): 1. Connection 11 RL 2. Connection 11 RR 3. Connection 11 PV 4. Ground (Cable to RA Block) Cable2 (PIN1: ye, PIN2: re, PIN3: gr, PIN4: br): 1. Connection 19 SV-LLA 2. Ground 3. Connection 20 SV-RLA 4. Ground (Cable to LA Block)
Spare Part: 472 905 107 0 Schlemmer Bayonet	Cable1 (PIN1: re, PIN2: gr, PIN3: ye, PIN4: br): 1. Connection 11 RL 2. Ground 3. Connection 11 PV 4. Ground (Cable to RA Block) Cable2 (PIN1: re, PIN2: gr, PIN3: ye, PIN4: br): 1. Ground 2. Connection 19 SV-LLA 3. Connection 20 SV-RLA 4. Ground (Cable to LA Block)

For trailers, pressure sensor variant 003 has been replaced by pressure sensor variant 007. Mind the changes of the pressure steps per count.

New parameters need to be set. Future versions do not change the sensor variant but the setting of the cables.

Table 7: Comparison of Height Sensor 441 050 ... 0

Used Height Sensor	Interface Cable/ Height Sensor	Cable used	Cable Dimension (Number of wires x area x length)	Wire Colours	Connector on the ECU (Con. = Connection)
441 050 011 0 Revised Version	Bayonet Connection to DIN 72585	449 742 050 0 (2-Pin)	2 x 0.75 ² x 5000	PIN1: black PIN2: brown	1. Con.12/13/14-HS... 2. Con.12/13/14-31
441 050 010 0 Original Version	Coupling Ring with Thread M 27x1	894 604 215 2 (2-Pin)	2 x 1.5 ² x 5000	PIN1: brown PIN2: blue	1. Con.12/13/14-31 2. Con.12/13/14-HS...

Trailer ECAS Parameter Setting			
Date		Checked by	
Manufacture		Proofed by	
Vehicle type		Electronic-No.	
Type		Software	
Calibration Height		Drawing No.	841 801
		Parameter No.	18
Comment			
Changes			
System Parameter			
No.	Meaning		Value
0	Trailer ECAS device address = 18		18
1	Option parameter 1	Value	Value
	Bit 0 = 0 must be set to 0 to ensure compatibility	0	
	Bit 1 = 0 air suspension only on rear axle	0	
	Bit 1 = 1 air suspension on front and rear axles (only permissible, if there is no 2nd lift axle)	2	
	Bit 2 = 0 trailer with lifting/trailing axle(s)	0	
	Bit 2 = 1 trailer without lifting/trailing axle(s)	4	
	Bit 3 = 0 system with pressure sensor	0	
	Bit 3 = 1 system without pressure sensor or lifting/trailing axle control with pressure switch (EBS)	8	
	Bit 4 = 0 two height sensors on the rear axle	0	
	Bit 4 = 1 only one height sensor on the rear axle	16	
	Bit 5 = 0 height sensor rear left side (connector position on ECU) (only if bit 4 = 1)	0	
	Bit 5 = 1 height sensor rear right side (only if bit 4 = 1)	32	
	Bit 6 = 0 three calibration levels	0	
	Bit 6 = 1 only drive level to be calibrated	64	
	Bit 7 = 0 adjustments according to option parameter (Bit 0-5 have to be set)	0	
	Bit 7 = 1 automatic periphery detection (Bit 0-5 without function)	128	
		Sum	0
2	Option parameter 2	Value	Value
	Bit 0 = 0 traction help type Germany (StVZO), max. 90sec., with rocket switch	0	
	Bit 0 = 1 traction help type EG, without time limitation, with rocket switch	1	
	Bit 1 = 0 traction help according to bit 0	0	
	Bit 1 = 1 traction help type "northern European countries", with switch	2	
	Bit 2 = 0 DL II via vehicle speed limit, defined in parameter	0	
	Bit 2 = 1 DL II via switch or remote control (see Parameter 3 bit 6)	4	
	Bit 3 = 0 half automatic lifting/trailing axle control (no traction help possible)	0	
	Bit 3 = 1 automatic lifting/trailing axle control	8	
	Bit 4 = 0 lifting/trailing axle control with pulse controlled 3/3 valve (at 1st lifting axle)	0	
	Bit 4 = 1 lifting/trailing axle control with spring returned 3/2 valve (at 1st lifting axle)	16	
	Bit 5 = 0 without traction help valve (only if bit 4 = 1)	0	
	Bit 5 = 1 with traction help valve (only if bit 4 = 1)	32	
	Bit 6 = 0 one separate lifting/trailing axle	0	
	Bit 6 = 1 two separate lifting/trailing axle (no front axle control possible)	64	
	Bit 7 = 0 without measurement data output	0	
	Bit 7 = 1 with measurement data output	128	
		Sum	0
3	Option parameter 3	Value	Value
	Bit 0 = 0 without load sensing valve	0	
	Bit 0 = 1 with load sensing valve	1	
	Bit 1 = 0 C3 signal monitoring for EBS, VCS and Vario-C with normal fault detection	0	
	Bit 1 = 1 C3 signal monitoring only for VCS with extended fault detection (short circuit to ground)	2	
	Bit 2 = 0 plausibility fault check, system switched off and fault display	0	
	Bit 2 = 1 plausibility warning, valves switched off, actual level=new DL	4	
	Bit 3 = 0 without operating data transfer on K-line (VCS)	0	
	Bit 3 = 1 with operating data transfer on K-line (C3, balg pressure) (EBS)	8	
	Bit 4 = 0 pressure sensor with output voltage amounting 5,5V at 10bar (1/20 bar per count 441 040 003 0)	0	
	Bit 4 = 1 pressure sensor with output voltage amounting to 4.5V at 10bar (1/16 bar per count 441 040 007 0)	16	
	Bit 5 = 0 unloading level via unloading level switch	0	
	Bit 5 = 1 DL III via normal level switch I/III or remote control (see bit 6)	32	
	Bit 6 = 0 DL via DL switch	0	
	Bit 6 = 1 DL via remote control	64	
	Bit 7 = 0 DL adjusted directly direct (Standard)	0	
	Bit 7 = 1 DL adjusted with compensation for bellow pressure differences	128	
		Sum	0

4 Option parameter 4		Value	Value
	Bit 0 = 0 traction help with pressure limit according to pressure defined in par. 37	0	
	Bit 0 = 1 traction help pressure rise by max.10% when traction help is started (parameter 28)	1	
	Bit 1 = 0 lifting axle lowered when ignition off	0	
	Bit 1 = 1 lifting axle remains in raised position when ignition off	2	
	Bit 2 = 0 lifting axle raised after ignition in (only with autom lift axle control, parameter 2 bit 3=1)	0	
	Bit 2 = 1 lifting axle raised after ignition on only when low speed is reached (see parameter 51)	4	
	Bit 3 = 0 DL increase for raised lifting axle (parameter 39) refers to the lowest DL defined in parameters	0	
	Bit 3 = 1 DL increase for raised lifting axle (parameter 39) effective in DL I and II, but not in DL III	8	
	Bit 4 = 0 switch input special functions (X15, ECU) means "forced lowering" for all lifting axles	0	
	Bit 4 = 1 switch input special functions (X15, ECU) means "forced lowering" for the 2nd lifting axle	16	
	Bit 5 to 7 without meaning	0	
		Sum	0
No.	Meaning	Unit	Value
5	difference of unloading level or DL III to DL I front	counts	
6	difference of unloading level or DL III to DL I rear	counts	
7	limit of plausibility fault detection front	counts	
8	limit of plausibility fault detection rear	counts	
9	tolerance for nominal level front (>= 3 counts)	counts	
10	tolerance for nominal level rear (>= 3 counts)	counts	
11	permissible deviation right/left in the nominal levels (>= 3 counts)	counts	
12	permissible deviation right/left beyond the nominal levels	counts	
13	permissible deviation front/rear beyond the nominal levels	counts	
14	permissible level increase 7 sec. after starting to drive or when unloading level function is activated	counts	
15	driving speed up to which selective height changes can be performed by the remote control	k.p.h.	
16	control delay during stand still	250 ms	
17	pulse repetition period T	25 ms	
18	buffer recognition time until the buffer is recognised and control is adjusted	250 ms	
19	proportional coefficient Kpf for nominal level control front	1/3 cts.	
20	proportional coefficient Kpf for nominal level control rear	1/3 cts.	
21	differential coefficient Kdf for nominal level control front	1/3 cts.	
22	differential coefficient Kdf for nominal level control rear	1/3 cts.	
23	difference of DL II to DL I front	counts	
24	difference of DL II to DL I rear	counts	
25	driving speed which, when exceeded, adjusts DL II automatically	k.p.h.	
26	driving speed which, when fallen below, adjusts DL I automatically	k.p.h.	
27	control delay during driving	250 ms	
28	pressure on the rear axle at which the lifting axle is lowered (charging TA)	1/16 bar	
29	pressure at the rear axle at which raising of the first lifting axle is possible (discharging TA)	1/16 bar	
30	over pressure at the rear axle	1/16 bar	
31	driving speed for manual lifting/trailing axle control	k.p.h.	
32	duration of traction help type Germany	5s	
33	duration of traction help type EG	5s	
34	forced pause after traction help	5s	
35	driving speed up to which traction help can be started	k.p.h.	
36	driving speed at which traction help is switched off	k.p.h.	
37	pressure at rear axle when traction help is activated	1/16 bar	
38	pressure hysteresis of axle load transfer during traction help	1/16 bar	
39	DL increase with raised lifting axle referred to the lowest driving level defined by par. or DL I and DLII resp.	counts	
40	plausibility fault detection delay	10 s	
41	speed which, when exceeded, leads to autom. activation of normal level (must not be < par. 15)	k.p.h.	
42	rear axle pressure which when exceeded leads to tire impression compensation	1/16 bar	
43	rear axle pressure at which the tire impression is compensated with max. offset	1/16 bar	
44	max. offset to compensate for the tire impression	counts	
45	pressure rear axle at which simultaneous raising of 1st and 2nd LA is possible (in case of 2 sep. LA)	1/16 bar	
46	pressure rear axle at which raising of 2nd lifting axle is possible (in case of 2 separate lifting axles)	1/16 bar	
47	stand by time when unloading level is switched on	10 s	
48	stand by operation period	15 min	
49	increased tolerance in stand by operation (front/rear) (only effective if > par 9 or 10)	counts	
50	period for plausibility fault detection	300 ms	
51	driving speed which when exceeded causes raising of lifting axle when all automatic LA control is active	k.p.h.	
52	level increase in case of traction help	counts	
....	without meaning		

Explanation of the Example Parameter Records

The example parameter records are suggestions. There are several ways to set the parameters. The example parameters are chosen for a bellows pressure of 4.0 bar supporting bellows pressure, which causes the lifting axle to lower. If the laden vehicle has a different supporting bellows pressure it is necessary to adjust it.

The parameter that might need to be adjusted are highlighted in grey.

All the lifting axle only raise if a speed greater than 20 k.p.h. is reached. They do not raise in standstill.

- If this is not wanted, change Parameter 4 or set Parameter 51 to 0 counts.
- If you only desire a driving level and no unloading level is needed, set Parameters 5, 6, 23 and 24 to 0 counts.

In the examples the driving level is activated automatically if the speed of 20 k.p.h. is exceeded.

The control unit remains active until automatic adjustment of the ride height has been completed.

Traction help is always designed as EC-traction help. It is turned off automatically if a speed of 30 k.p.h is exceeded. An offset of 10 counts will be set.

If the permissible axle load is exceeded by 50% on vehicles with a pressure sensor or vehicles with EBS the vehicle is lowered in standstill.

- If this is not desired set Parameter 30 to 255 counts.

The speed for manual raising of the lifting axle is restricted to 20 k.p.h.

Table 8: Vehicles with ABS + ECAS

Circuit Diagram Number	Number of Items Axles on the Trailer	Type of Trailer	Number of Height Sensor/Axle	Right/Left Control	Number of Items Lifting Axles	Number of Trailing Axle Control	Remark
841 801 739 0							Additional uses for Vario C
841 801 720 0	3	Drawbar	2				With front axle valve
841 801 721 0	2-3-4	Drawbar	2				Without calve throttle
841 801 722 0	1-2-3	Semi	1				
841 801 723 0	2-3	Semi	1		1		
841 801 724 0	2-3	Semi	2	X	1		
841 801 725 0	2-3	Semi	2		1		
841 801 726 0	3	Semi	1		2 separate		
841 801 727 0	2-3	Semi	1			1	
841 801 728 0	2-3-4	Drawbar	3				With front axle valve
841 801 729 0	3-4	Drawbar	3		1		With front axle valve
841 801 730 0	2-3	Semi	1		1		Train transport
841 801 731 0	2-3	Semi	1				With traction help
841 801 732 0	1-3	Semi	1				Tyre-deflection compensation
841 801 733 0	3	Semi	2		2 separate		
841 801 734 0	3	Semi	2	X	2		
841 801 735 0	2-3	Semi	2				
841 801 736 0	3	Semi	1		2 separate		
841 801 737 0	2-3	Semi	2	X			
841 801 738 0	3-4	Drawbar	2		1		With front axle valve
841 801 780 0	3	Semi	1		2 parallel		
841 801 781 0	2-3	Drawbar	2				With front axle valve, train transport
841 801 782 0	2-3	Semi	2				Tyre-deflection compensation
841 801 828 0							Control and battery box for VCS
841 801 829 0							Control and battery box for EBS

Table 9: Vehicles with EBS + ECAS

Circuit Diagram Number	No. of Items Axles on the Trailer	Type of Trailer	No of Items Height Sens./Axle	Right/Left Control	Number of Lifting Axles	Remark
841 801 750 0	2-3-4	Drawbar	2			with front axle valve
841 801 751 0	2-3-4	Drawbar	2			without front axle valve
841 801 752 0	1-2-3	Semi	1			
841 801 753 0	2-3	Semi	1		1	
841 801 754 0	2-3	Semi	2	X	1	
841 801 755 0	2-3	Semi	2		1	
841 801 756 0	3	Semi	1		2 separate	
841 801 757 0	2-3	Semi	1			1 Trailing axle control
841 801 758 0	2-3-4	Drawbar	3			With front axle valve
841 801 759 0	3-4	Drawbar	3		1	With front axle valve
841 801 760 0	2-3	Semi	1		1	Train transport
841 801 761 0	2-3	Semi	1			With traction help
841 801 762 0	1-3	Semi	1			Tyre-deflection compensation
841 801 763 0	3	Semi	2		2 separate	
841 801 764 0	3	Semi	2	X	2	
841 801 765 0	2-3	Semi	2			
841 801 766 0	3	Semi	1		2 separate	
841 801 767 0	2-3	Semi	2	X		
841 801 768 0	3-4	Drawbar	2		1	With front axle valve
841 801 769 0	3	Semi	1		2 parallel	
841 801 820 0	2-3	Drawbar	2			With front axle valve, train transport
841 801 821 0	2-3	Semi	2			Tyre-deflection compensation
841 801 822 0	3	Semi	1			1. Axle traction help 3. Axle maneuver aid
841 801 823 0	3	Semi	1		2 separate	2. Lifting axle maneuver aid + automatic lowering
841 801 824 0	3	Semi	1		1	Single circuit
841 801 825 0	3 axles	Semi	1		2	Single circuit
841 801 826 0	3 axles	Semi	1		2 separate	
841 801 827 0	3 axles	Semi	1		1	Without traction help

List of Parameters Trailer ECAS

ECU Variant: 446 055 065 0

Circuit Diagram No.: 841 801 720 0

Parameter Record No.: 8418017200

Par.	Value	Unit
P 0	= 18	
P 1	= 30	
P 2	= 13	
P 3	= 116	
P 4	= 0	
P 5	= 15	counts
P 6	= 15	counts
P 7	= 115	counts
P 8	= 115	counts
P 9	= 5	counts
P10	= 5	counts
P11	= 255	counts
P12	= 255	counts
P13	= 15	counts
P14	= 20	counts
P15	= 15	k.p.h.
P16	= 8	250ms
P17	= 12	25ms
P18	= 80	250ms
P19	= 10	1/3counts

Par.	Value	Unit
P20	= 10	1/3counts
P21	= 20	1/3counts
P22	= 20	1/3counts
P23	= 115	counts
P24	= 115	counts
P25	= 255	k.p.h.
P26	= 0	k.p.h.
P27	= 240	250ms
P28	= 0	1/16bar
P29	= 0	1/16bar
P30	= 255	1/16bar
P31	= 0	k.p.h.
P32	= 0	5s
P33	= 0	5s
P34	= 0	5s
P35	= 0	k.p.h.
P36	= 0	k.p.h.
P37	= 0	1/16bar
P38	= 0	1/16bar
P39	= 0	counts

Par.	Value	Unit
P40	= 120	10s
P41	= 20	k.p.h.
P42	= 0	1/16bar
P43	= 0	1/16bar
P44	= 0	counts
P45	= 0	1/16bar
P46	= 0	1/16bar
P47	= 0	10s
P48	= 48	15min
P49	= 10	counts
P50	= 100	300ms
P51	= 0	k.p.h.
P52	= 0	counts

System Description:

drawbar trailer with two height sensors
 no lifting axle control / no traction help
 raising/lowering from remote-control unit up to calibrated upper value and mechanical stop at bottom
 automatic driving level from 20 k.p.h.
 3 driving levels selectable from remote-control unit
 DL III > DL I > DL II
 remote-control unit cleared up to 15 k.p.h.
 2 freely programmable memory levels via remote-control unit
 2 seconds control delay while stationary and 60 seconds when in motion
 power supply from WABCO-ABS-System VCS

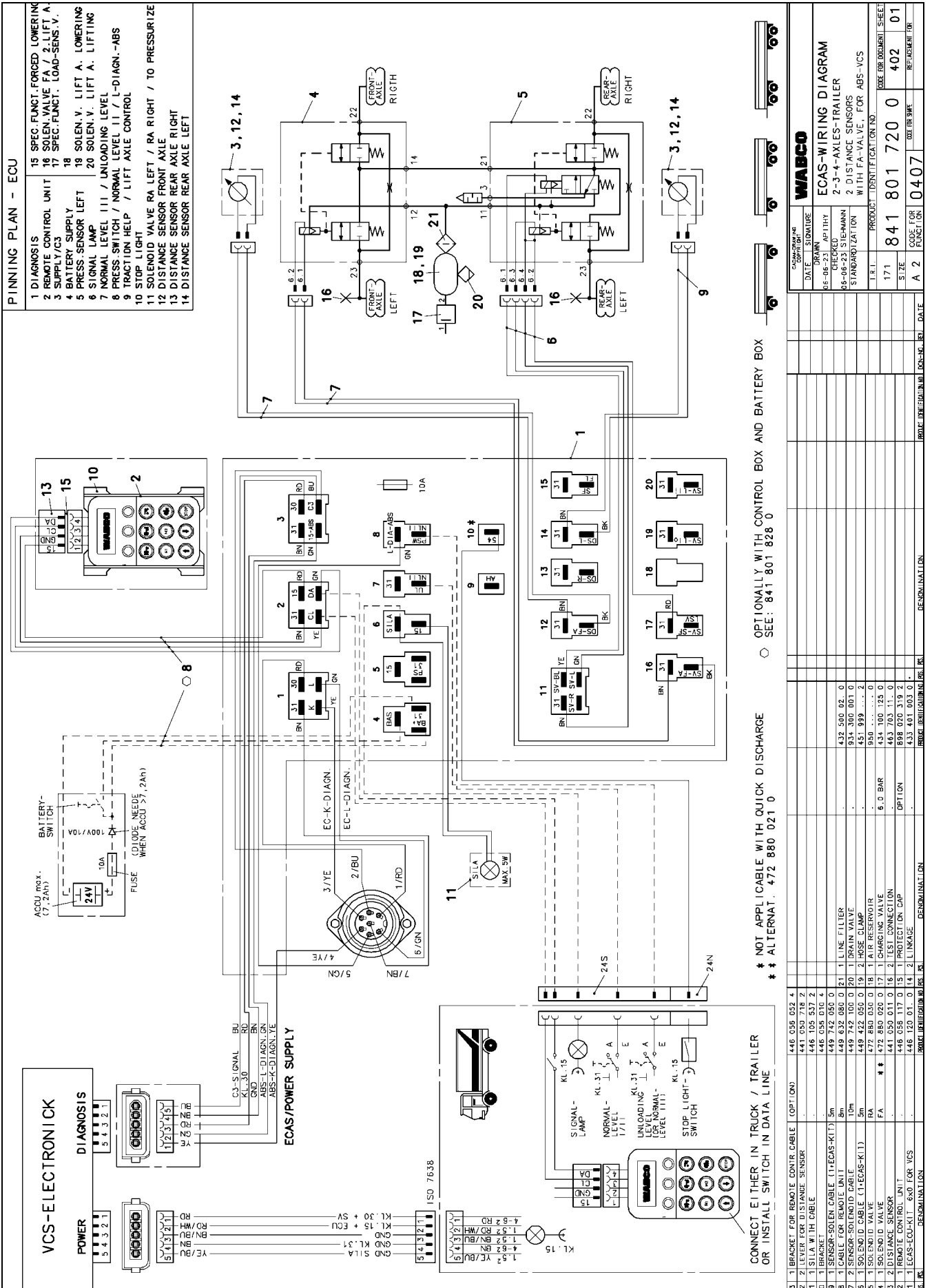

List of Parameters Trailer ECAS

ECU Variant: 446 055 065 0
Circuit Diagram No.: 841 801 721 0
Parameter Record No.: 8418017210

Par.		Value	Unit
P 0	=	18	
P 1	=	30	
P 2	=	13	
P 3	=	116	
P 4	=	0	
P 5	=	15	counts
P 6	=	15	counts
P 7	=	115	counts
P 8	=	115	counts
P 9	=	5	counts
P10	=	5	counts
P11	=	255	counts
P12	=	255	counts
P13	=	15	counts
P14	=	20	counts
P15	=	15	k.p.h.
P16	=	8	250ms
P17	=	12	25ms
P18	=	80	250ms
P19	=	10	1/3counts

Par.		Value	Unit
P20	=	10	1/3counts
P21	=	20	1/3counts
P22	=	20	1/3counts
P23	=	115	counts
P24	=	115	counts
P25	=	255	k.p.h.
P26	=	0	k.p.h.
P27	=	240	250ms
P28	=	0	1/16bar
P29	=	0	1/16bar
P30	=	255	1/16bar
P31	=	0	k.p.h.
P32	=	0	5s
P33	=	0	5s
P34	=	0	5s
P35	=	0	k.p.h.
P36	=	0	k.p.h.
P37	=	0	1/16bar
P38	=	0	1/16bar
P39	=	0	counts

Par.		Value	Unit
P40	=	120	10s
P41	=	20	k.p.h.
P42	=	0	1/16bar
P43	=	0	1/16bar
P44	=	0	counts
P45	=	0	1/16bar
P46	=	0	1/16bar
P47	=	0	10s
P48	=	48	15min
P49	=	10	counts
P50	=	100	300ms
P51	=	0	k.p.h.
P52	=	0	counts

System Description:

drawbar trailer with two height sensors
no lifting axle control / no traction help
raising/lowering from remote-control unit up to calibrated upper value and mechanical stop at bottom
automatic driving level from 20 k.p.h.
3 driving levels selectable from remote-control unit
DL III > DL I > DL II
remote-control unit cleared up to 15 k.p.h.
2 freely programmable memory levels via remote-control unit
2 seconds control delay while stationary and 60 seconds when in motion
no transverse throttle, only 1 solenoid valve, follow pipe lengths/diameters!
power supply from WABCO-ABS-System VCS

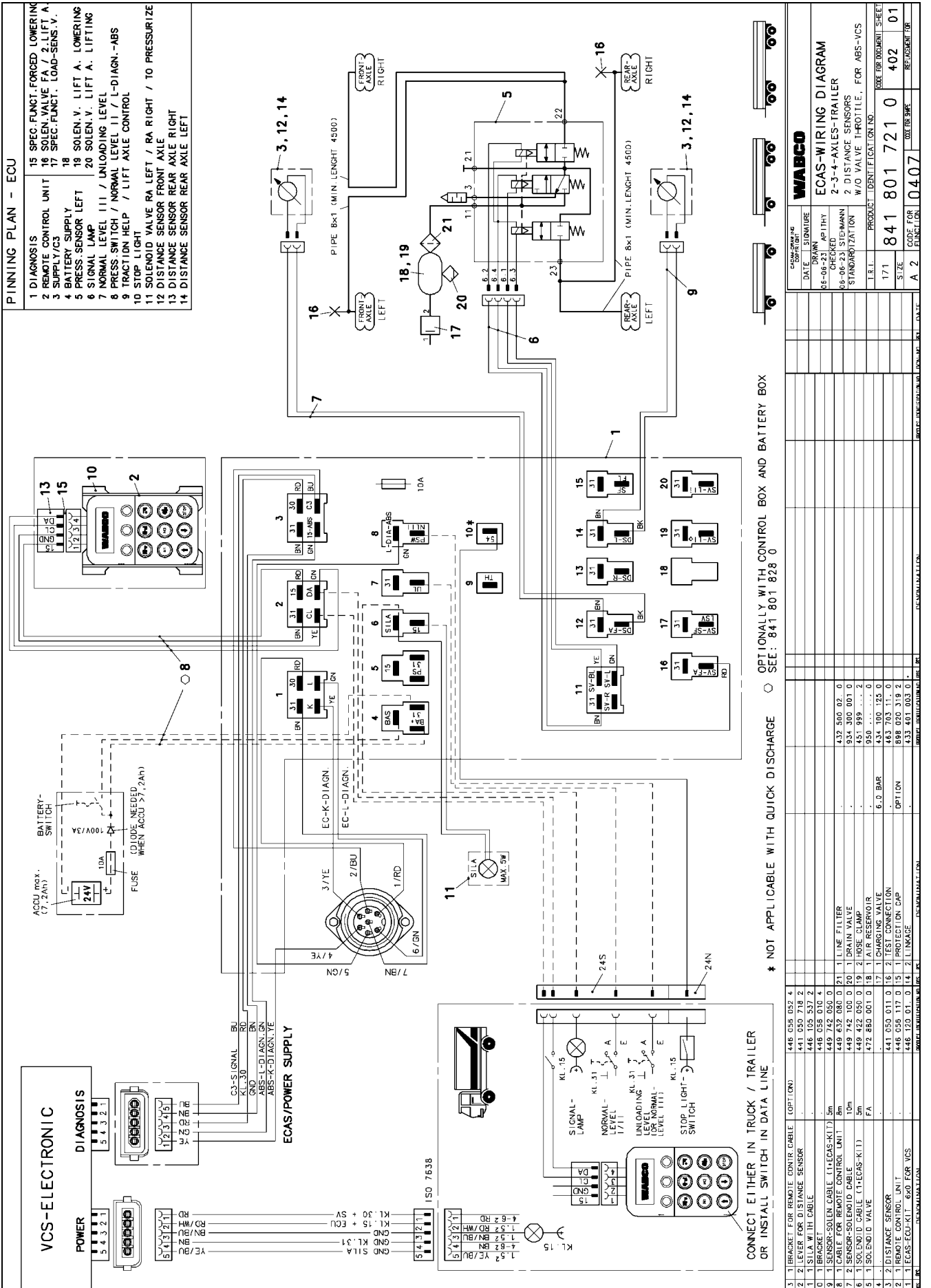

List of Parameters Trailer ECAS

ECU Variant: 446 055 065 0

Circuit Diagram No.: 841 801 722 0

Parameter Record No.: 8418017220

Par.		Value	Unit
P 0	=	18	
P 1	=	28	
P 2	=	12	
P 3	=	116	
P 4	=	0	
P 5	=	0	counts
P 6	=	15	counts
P 7	=	0	counts
P 8	=	115	counts
P 9	=	0	counts
P10	=	5	counts
P11	=	255	counts
P12	=	255	counts
P13	=	255	counts
P14	=	20	counts
P15	=	15	k.p.h.
P16	=	8	250ms
P17	=	12	25ms
P18	=	80	250ms
P19	=	0	1/3counts

Par.		Value	Unit
P20	=	10	1/3counts
P21	=	0	1/3counts
P22	=	20	1/3counts
P23	=	0	counts
P24	=	115	counts
P25	=	255	k.p.h.
P26	=	0	k.p.h.
P27	=	240	250ms
P28	=	0	1/16bar
P29	=	0	1/16bar
P30	=	255	1/16bar
P31	=	0	k.p.h.
P32	=	0	5s
P33	=	0	5s
P34	=	0	5s
P35	=	0	k.p.h.
P36	=	0	k.p.h.
P37	=	0	1/16bar
P38	=	0	1/16bar
P39	=	0	counts

Par.		Value	Unit
P40	=	120	10s
P41	=	20	k.p.h.
P42	=	0	1/16bar
P43	=	0	1/16bar
P44	=	0	counts
P45	=	0	1/16bar
P46	=	0	1/16bar
P47	=	0	10s
P48	=	48	15min
P49	=	10	counts
P50	=	100	300ms
P51	=	0	k.p.h.
P52	=	0	counts

System Description:

- semitrailer with one height sensor
- no lifting axle control / traction help
- raising/lowering from remote-control unit up to calibrated upper value and mechanical stop at bottom
- automatic driving level from 20 k.p.h.
- 3 driving levels selectable from remote-control unit
- DL III > DL I > DL II
- remote-control unit cleared up to 15 k.p.h
- 2 freely programmable memory levels via remote-control unit
- 2 seconds control delay while stationary and 60 seconds when in motion
- power supply from WABCO-ABS-System VCS

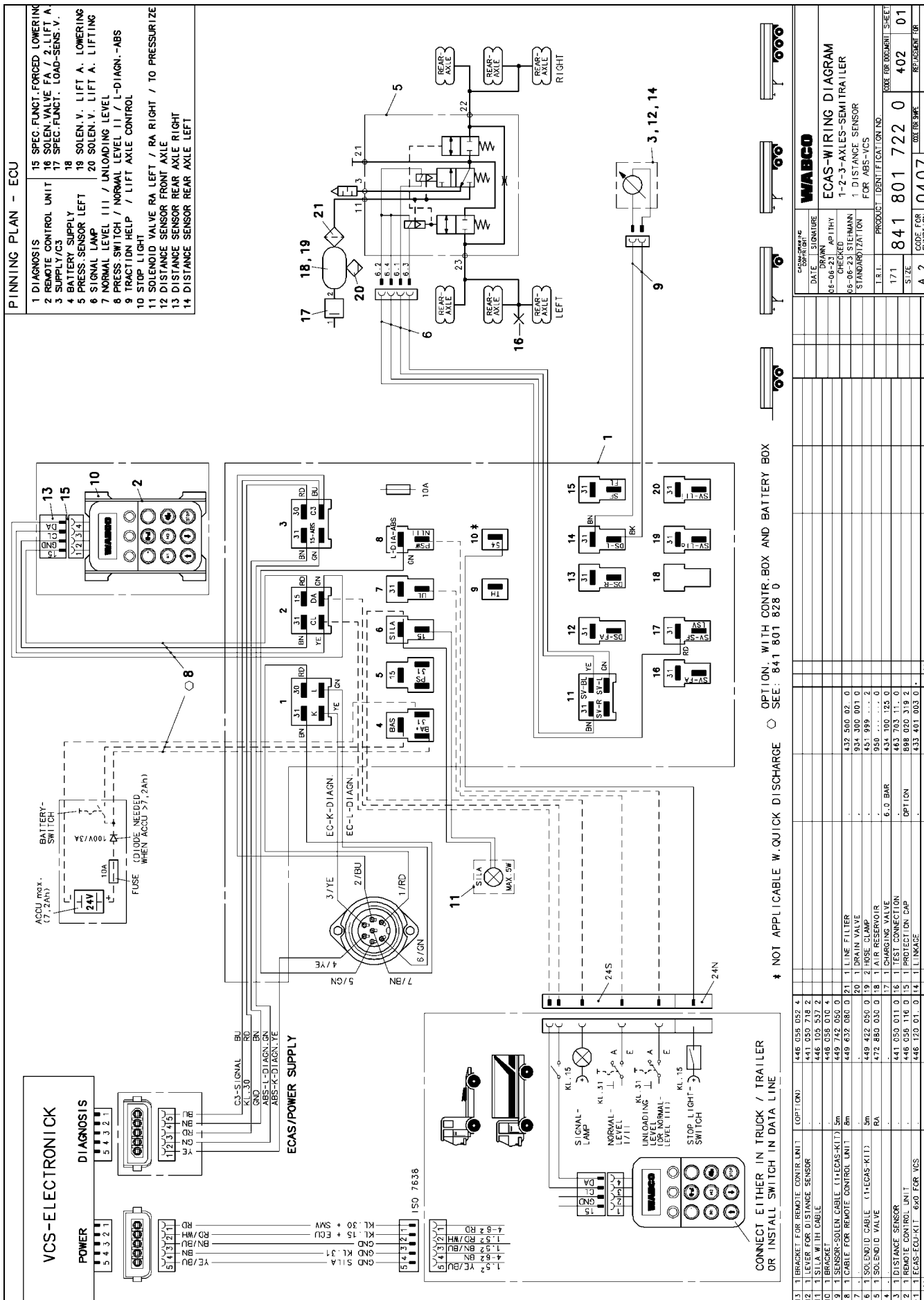

COMPARTMENT		WABCO	
DATE	SIGNATURE	ECAS-WIRING DIAGRAM	
06-06	PH/TH	1-2-3-AXLES-SEMITRAILER	
06-06	CHECKED	1 DISTANCE SENSOR	
06-06	23 STEFANN	FOR ABS-VCS	
STANDARDIZATION		PRODUCT IDENTIFICATION NO.	
L.R.I.	17.1	841 801 722 0	USE FOR ORDER SHEET
SIZE	A 2	402	REFUSEMENT FOR
CODE FOR FUNCTION	04.07		

31	1	BRACKET FOR REMOTE CONTROL UNIT (OPT.ON)	148 058 052 4
31	2	1 LEVER FOR DISTANCE SENSOR	441 050 718 2
31	3	1 BRACKET WITH CABLE	446 105 537 2
31	4	1 BRACKET	446 058 010 4
31	5	1 SENSOR-SOLENID CABLE (1+ECAS-KIT) 5m	449 742 050 0
31	6	1 CABLE FOR REMOTE CONTROL UNIT 5m	449 632 080 0 21
31	7	1 LINE FILTER	432 500 02 0
31	8	1 DRAIN VALVE	934 300 001 0
31	9	2 HOSE CLAMP	451 999 ... 2
31	10	1 AIR RESERVOIR	950 ... 0
31	11	1 SOLENOID VALVE	441 050 011 0
31	12	1 PRESSURE VALVE	443 700 023 0
31	13	1 PRESSURE SWITCH	443 700 011 0
31	14	1 PROTECT ON CAP	898 020 319 2
31	15	1 PROTECT ON CAP	898 020 319 2
31	16	1 LINKAGE	433 001 003 0
31	17	1 LINKAGE	433 001 003 0
31	18	1 LINKAGE	433 001 003 0
31	19	1 LINKAGE	433 001 003 0
31	20	1 LINKAGE	433 001 003 0

List of Parameters Trailer ECAS

ECU Variant: 446 055 065 0

Circuit Diagram No.: 841 801 723 0

Parameter Record No.: 8418017230

Par.	Value	Unit
P 0	= 18	
P 1	= 16	
P 2	= 13	
P 3	= 84	
P 4	= 5	
P 5	= 0	counts
P 6	= 160	counts
P 7	= 0	counts
P 8	= 115	counts
P 9	= 0	counts
P10	= 5	counts
P11	= 255	counts
P12	= 255	counts
P13	= 255	counts
P14	= 20	counts
P15	= 15	k.p.h.
P16	= 8	250ms
P17	= 12	25ms
P18	= 80	250ms
P19	= 0	1/3counts

Par.	Value	Unit
P20	= 10	1/3counts
P21	= 0	1/3counts
P22	= 20	1/3counts
P23	= 0	counts
P24	= 15	counts
P25	= 255	k.p.h.
P26	= 0	k.p.h.
P27	= 240	250ms
P28	= 64	1/16bar
P29	= 38	1/16bar
P30	= 96	1/16bar
P31	= 20	k.p.h.
P32	= 18	5s
P33	= 255	5s
P34	= 0	5s
P35	= 20	k.p.h.
P36	= 30	k.p.h.
P37	= 83	1/16bar
P38	= 4	1/16bar
P39	= 10	counts

Par.	Value	Unit
P40	= 120	10s
P41	= 20	k.p.h.
P42	= 0	1/16bar
P43	= 0	1/16bar
P44	= 0	counts
P45	= 0	1/16bar
P46	= 0	1/16bar
P47	= 30	10s
P48	= 48	15min
P49	= 10	counts
P50	= 100	300ms
P51	= 20	k.p.h.
P52	= 10	counts

System Description:

- semitrailer with one height sensor
- automatic lifting axle control and EC traction help
- lowering of lifting axle at a pressure of 4 bar in the supporting bellows
- raising the lifting axle at a pressure of 2.4 bar in the supporting bellows
- lowering to the buffers due to 50% excess weight at a pressure of 6 bar in the supporting bellows
- traction help pressure of 5.2 bar in the supporting bellows
- starting traction help via remote-control unit or rocking switch
- ending traction help by pushing Stop button or holding rocking switch down for more than 5 sec. or Vlimit > 30 k.p.h.
- lifting axle is lowered after ignition OFF
- lifting axle is raised after vehicle was stopped once and subsequently moved at >20 k.p.h. up to 2.4 bar
- raising the level by 10 counts at driving level for improved tyre clearance when lifting axle is raised
- raising the level by 10 counts when traction help is active
- unloading level to buffer when switch has been activated (160 counts)
- raising/lowering from remote-control unit up to calibrated upper value and mechanical stop at bottom
- automatic driving level from 20 k.p.h.
- 2 driving levels selectable from remote-control unit
- DL II > DL I
- remote-control unit cleared up to 15 k.p.h.
- 2 freely programmable memory levels via remote-control unit
- 2 seconds control delay while stationary and 60 seconds when in motion
- power supply from WABCO-ABS-System VCS

bellows pressure laden 4.0 bar

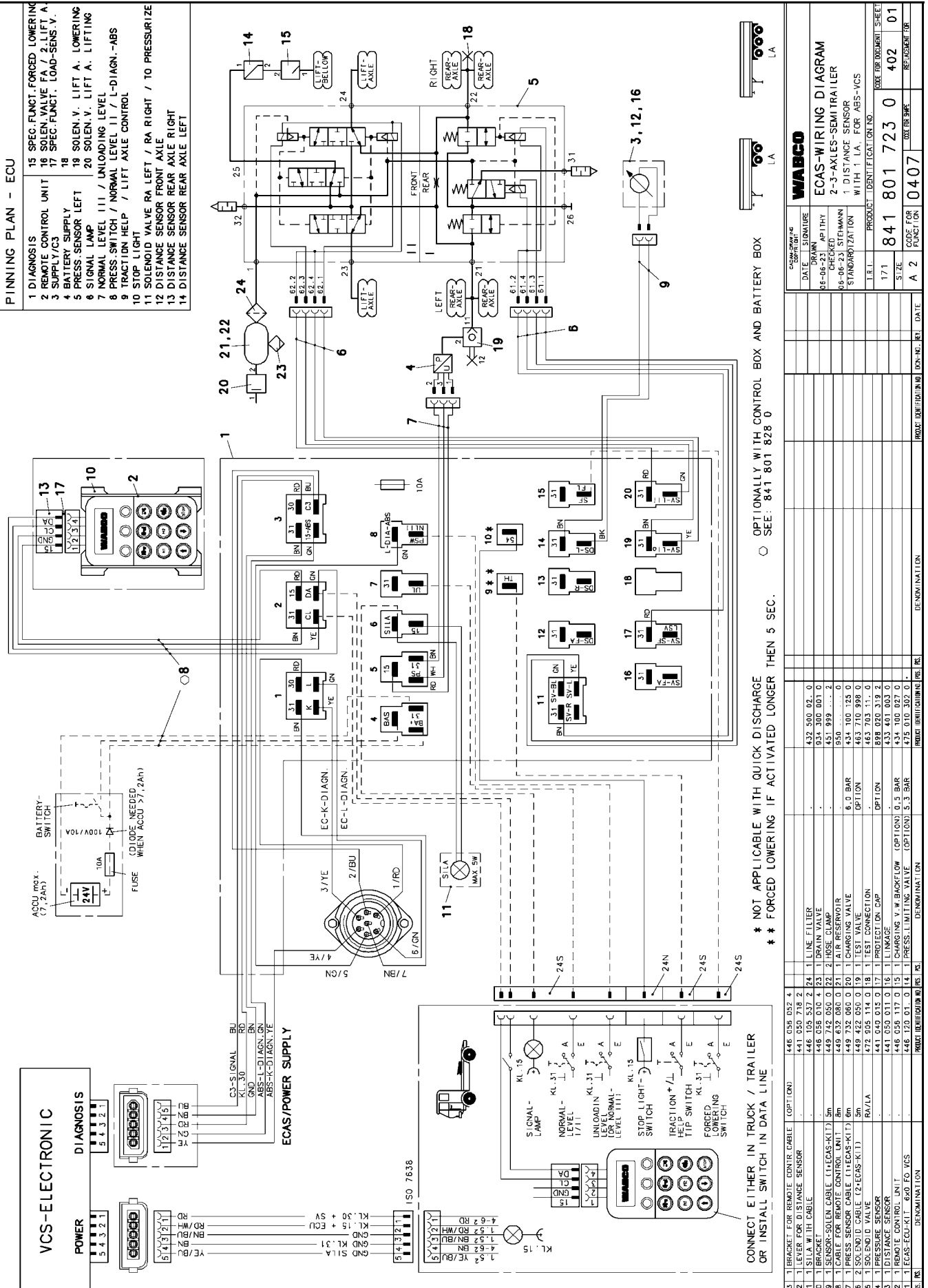

List of Parameters Trailer ECAS

ECU Variant: 446 055 065 0

Circuit Diagram No.: 841 801 724 0

Parameter Record No.: 8418017240

Par.		Value	Unit
P 0	=	18	
P 1	=	50	
P 2	=	13	
P 3	=	212	
P 4	=	5	
P 5	=	160	counts
P 6	=	160	counts
P 7	=	115	counts
P 8	=	115	counts
P 9	=	5	counts
P10	=	5	counts
P11	=	255	counts
P12	=	255	counts
P13	=	255	counts
P14	=	20	counts
P15	=	15	k.p.h.
P16	=	8	250ms
P17	=	12	25ms
P18	=	80	250ms
P19	=	10	1/3counts

Par.		Value	Unit
P20	=	10	1/3counts
P21	=	20	1/3counts
P22	=	20	1/3counts
P23	=	15	counts
P24	=	15	counts
P25	=	255	k.p.h.
P26	=	0	k.p.h.
P27	=	240	250ms
P28	=	64	1/16bar
P29	=	38	1/16bar
P30	=	96	1/16bar
P31	=	20	k.p.h.
P32	=	18	5s
P33	=	255	5s
P34	=	0	5s
P35	=	20	k.p.h.
P36	=	30	k.p.h.
P37	=	83	1/16bar
P38	=	4	1/16bar
P39	=	10	counts

Par.		Value	Unit
P40	=	120	10s
P41	=	20	k.p.h.
P42	=	0	1/16bar
P43	=	0	1/16bar
P44	=	0	counts
P45	=	0	1/16bar
P46	=	0	1/16bar
P47	=	30	10s
P48	=	48	15min
P49	=	10	counts
P50	=	100	300ms
P51	=	20	k.p.h.
P52	=	10	counts

System Description:

semitrailer with two height sensors
 automatic lifting axle control and EC traction help
 lowering of lifting axle at a pressure of 4 bar in the supporting bellows
 raising the lifting axle at a pressure of 2.4 bar in the supporting bellows
 lowering to the buffers due to 50% excess weight at a pressure of 6 bar in the supporting bellows
 traction help pressure of 5.2 bar in the supporting bellows
 starting traction help via remote-control unit or rocking switch
 ending traction help by pushing Stop button or holding rocking switch down for more than 5 sec. or Vlimit > 30 k.p.h.
 lifting axle is lowered after ignition OFF
 lifting axle is raised after vehicle was stopped once and subsequently moved at >20 k.p.h. up to 2.4 bar
 raising the level by 10 counts at driving level for improved tyre clearance when lifting axle is raised
 raising the level by 10 counts when traction help is active
 unloading level to buffer when switch has been activated (160 counts)
 raising/lowering from remote-control unit up to calibrated upper value and mechanical stop at bottom
 automatic driving level from 20 k.p.h.
 2 driving levels selectable from remote-control unit
 DL II > DL I
 remote-control unit cleared up to 15 k.p.h.
 2 freely programmable memory levels via remote-control unit
 left/right control of vehicle possible from remote-control unit (raise/lower) (left = front, right = rear)
 2 seconds control delay while stationary and 60 seconds when in motion
 power supply from WABCO-ABS-System VCS

bellows pressure laden 4.0 bar

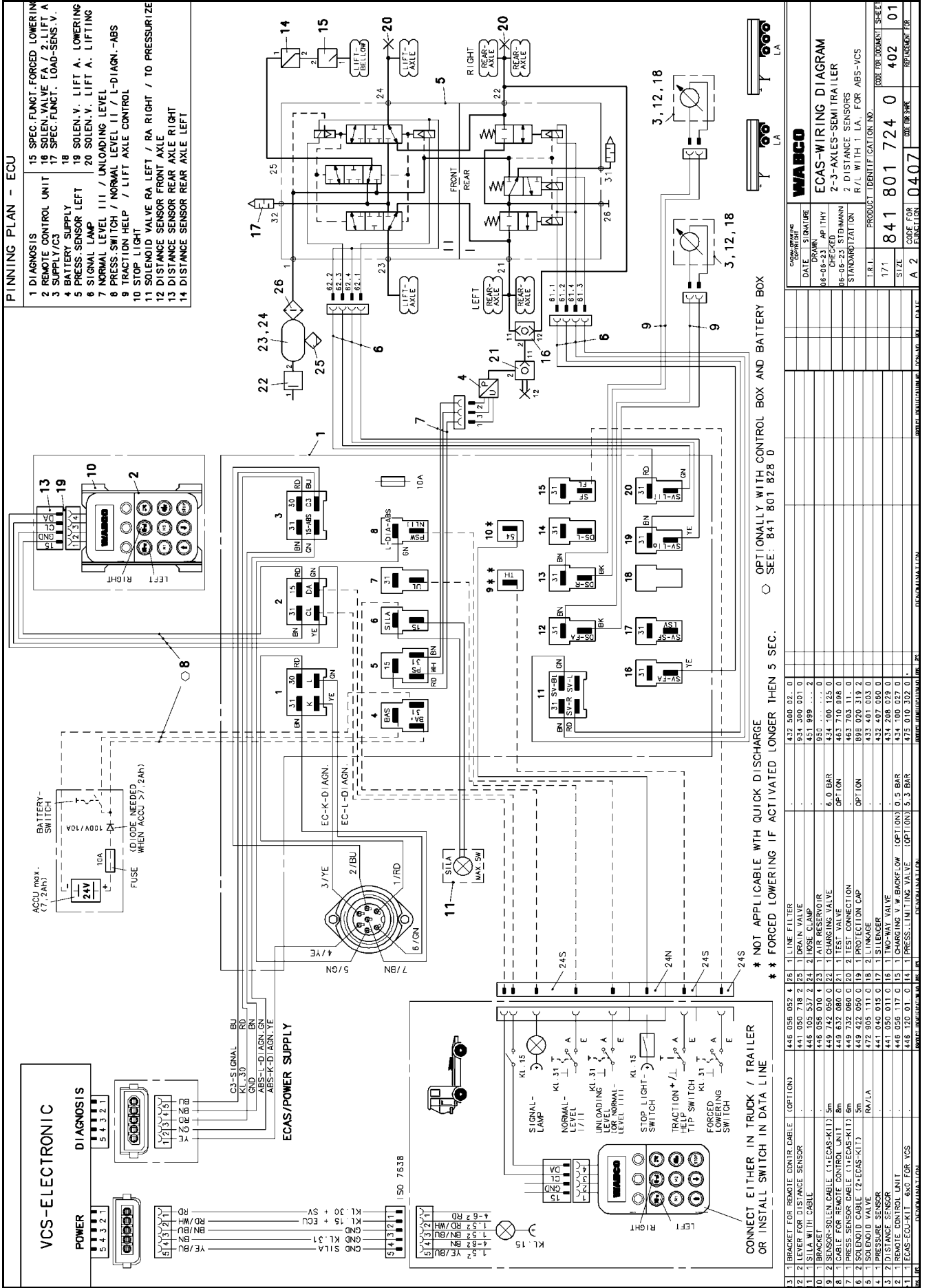

List of Parameters Trailer ECAS

ECU Variant: 446 055 065 0

Circuit Diagram No.: 841 801 725 0

Parameter Record No.: 8418017250

Par.		Value	Unit
P 0	=	18	
P 1	=	0	
P 2	=	13	
P 3	=	244	
P 4	=	5	
P 5	=	0	counts
P 6	=	15	counts
P 7	=	0	counts
P 8	=	115	counts
P 9	=	0	counts
P10	=	5	counts
P11	=	6	counts
P12	=	255	counts
P13	=	255	counts
P14	=	20	counts
P15	=	15	k.p.h.
P16	=	8	250ms
P17	=	12	25ms
P18	=	80	250ms
P19	=	0	1/3counts

Par.		Value	Unit
P20	=	10	1/3counts
P21	=	0	1/3counts
P22	=	20	1/3counts
P23	=	0	counts
P24	=	115	counts
P25	=	255	k.p.h.
P26	=	0	k.p.h.
P27	=	240	250ms
P28	=	64	1/16bar
P29	=	38	1/16bar
P30	=	96	1/16bar
P31	=	20	k.p.h.
P32	=	18	5s
P33	=	255	5s
P34	=	0	5s
P35	=	20	k.p.h.
P36	=	30	k.p.h.
P37	=	83	1/16bar
P38	=	4	1/16bar
P39	=	10	counts

Par.		Wert	Unit
P40	=	120	10s
P41	=	20	k.p.h.
P42	=	0	1/16bar
P43	=	0	1/16bar
P44	=	0	counts
P45	=	0	1/16bar
P46	=	0	1/16bar
P47	=	0	10s
P48	=	48	15min
P49	=	10	counts
P50	=	100	300ms
P51	=	20	k.p.h.
P52	=	10	counts

System Description:

semitrailer with two height sensors
 automatic lifting axle control and EC traction help
 lowering of lifting axle at a pressure of 4 bar in the supporting bellows
 raising the lifting axle at a pressure of 2.4 bar in the supporting bellows
 lowering to the buffers due to 50% excess weight at a pressure of 6 bar in the supporting bellows
 traction help pressure of 5.2 bar in the supporting bellows
 starting traction help via remote-control unit or rocking switch
 ending traction help by pushing Stop button or holding rocking switch down for more than 5 sec. or Vlimit > 30 k.p.h.
 lifting axle is lowered after ignition OFF
 lifting axle is raised after vehicle was stopped once and subsequently moved at >20 k.p.h. up to 2.4 bar
 raising the level by 10 counts at driving level for improved tyre clearance when lifting axle is raised
 raising the level by 10 counts when traction help is active
 unloading level to buffer when switch has been activated (160 counts)
 raising/lowering from remote-control unit up to calibrated upper value and mechanical stop at bottom
 automatic driving level from 20 k.p.h.
 2 driving levels selectable from remote-control unit
 DL II > DL I
 remote-control unit cleared up to 15 k.p.h.
 2 freely programmable memory levels via remote-control unit
 2 seconds control delay while stationary and 60 seconds when in motion
 power supply from WABCO-ABS-System VCS

bellows pressure laden 4.0 bar

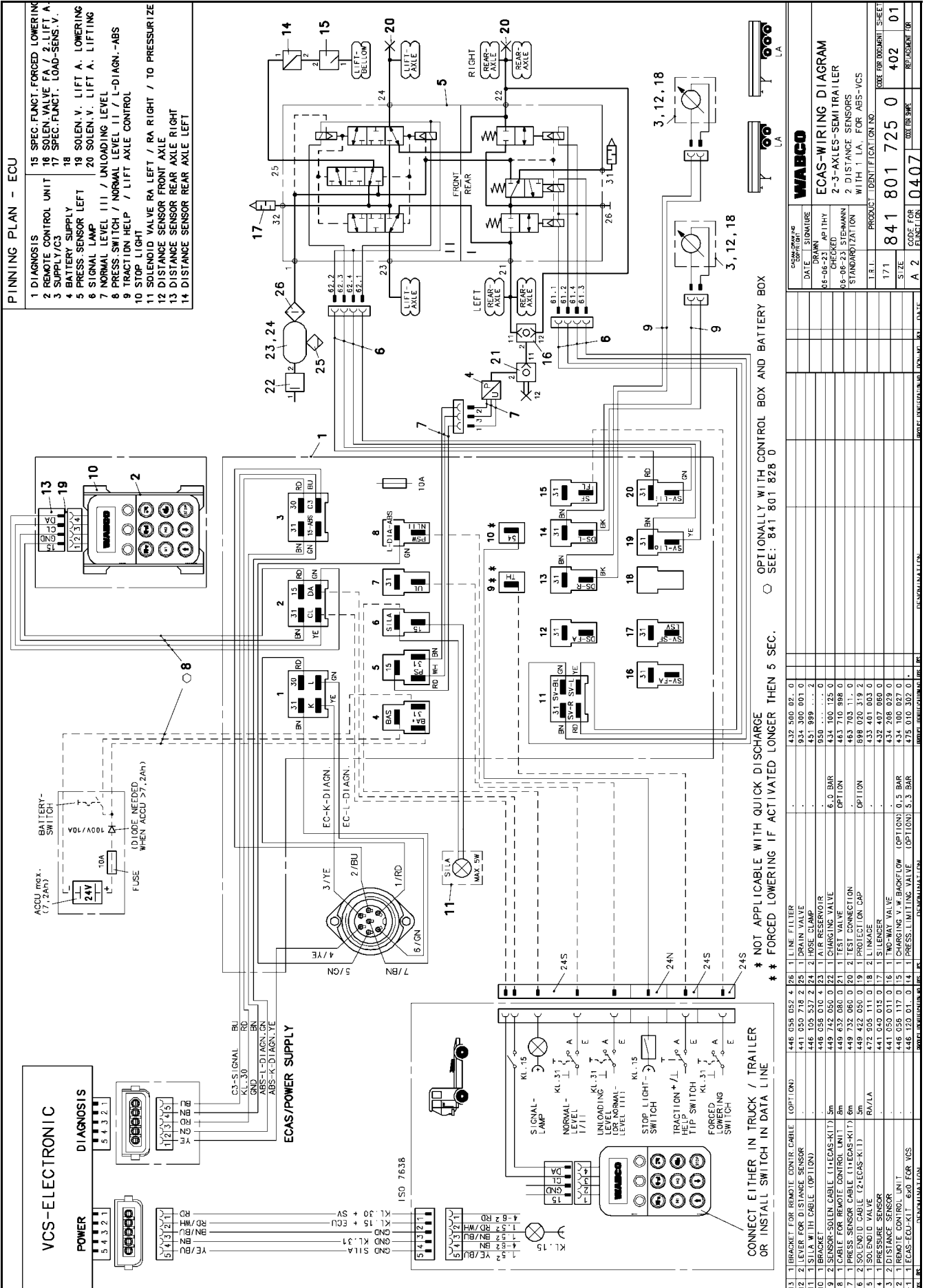

List of Parameters Trailer ECAS

ECU Variant: 446 055 065 0

Circuit Diagram No.: 841 801 726 0

Circuit Diagram No.: 8418017260

Par.	Value	Unit
P 0 =	18	
P 1 =	16	
P 2 =	77	
P 3 =	84	
P 4 =	5	
P 5 =	0	counts
P 6 =	160	counts
P 7 =	0	counts
P 8 =	115	counts
P 9 =	0	counts
P10 =	5	counts
P11 =	255	counts
P12 =	255	counts
P13 =	255	counts
P14 =	20	counts
P15 =	15	k.p.h.
P16 =	8	250ms
P17 =	12	25ms
P18 =	80	250ms
P19 =	0	1/3counts

Par.	Value	Unit
P20 =	10	1/3counts
P21 =	0	1/3counts
P22 =	20	1/3counts
P23 =	0	counts
P24 =	15	counts
P25 =	255	k.p.h.
P26 =	0	k.p.h.
P27 =	240	250ms
P28 =	64	1/16bar
P29 =	38	1/16bar
P30 =	96	1/16bar
P31 =	20	k.p.h.
P32 =	18	5s
P33 =	255	5s
P34 =	0	5s
P35 =	20	k.p.h.
P36 =	30	k.p.h.
P37 =	83	1/16bar
P38 =	4	1/16bar
P39 =	10	counts

Par.	Value	Unit
P40 =	120	10s
P41 =	20	k.p.h.
P42 =	0	1/16bar
P43 =	0	1/16bar
P44 =	0	counts
P45 =	17	1/16bar
P46 =	25	1/16bar
P47 =	30	10s
P48 =	48	15min
P49 =	10	counts
P50 =	100	300ms
P51 =	20	k.p.h.
P52 =	10	counts

System Description:

semitrailer with one height sensor

automatic lifting axle control for two separate lifting axles and EC traction help on Axle 1

lowering of lifting axle(s) at a pressure of 4 bar in the supporting bellows

raising the first lifting axle at a pressure of 2.4 bar in the supporting bellows

raising the second lifting axle at a pressure of 1.6 bar in the supporting bellows

simultaneously raising both lifting axle up to a pressure of 1.1 bar in the supporting bellows

lowering to the buffers due to 50% excess weight at a pressure of 6 bar in the supporting bellows

traction help pressure of 5.2 bar in the supporting bellows

starting traction help via remote-control unit or rocking switch

ending traction help by pushing Stop button or holding rocking switch down for more than 5 sec. or Vlimit > 30 k.p.h.

lifting axle is lowered after ignition OFF

lifting axle(s) is (are) raised after vehicle was stopped once and subsequently moved at >20 k.p.h. up to 2.4 bar

raising the level by 10 counts at driving level for improved tyre clearance when lifting axle is raised

raising the level by 10 counts when traction help is active

unloading level to buffer when switch has been activated (160 counts)

raising/lowering from remote-control unit up to calibrated upper value and mechanical stop at bottom

automatic driving level from 20 k.p.h.

2 driving levels selectable from remote-control unit

DL II > DL I

remote-control unit cleared up to 15 k.p.h.

2 freely programmable memory levels via remote-control unit

2 seconds control delay while stationary and 60 seconds when in motion

power supply from WABCO-ABS-System VCS

bellows pressure laden 4.0 bar

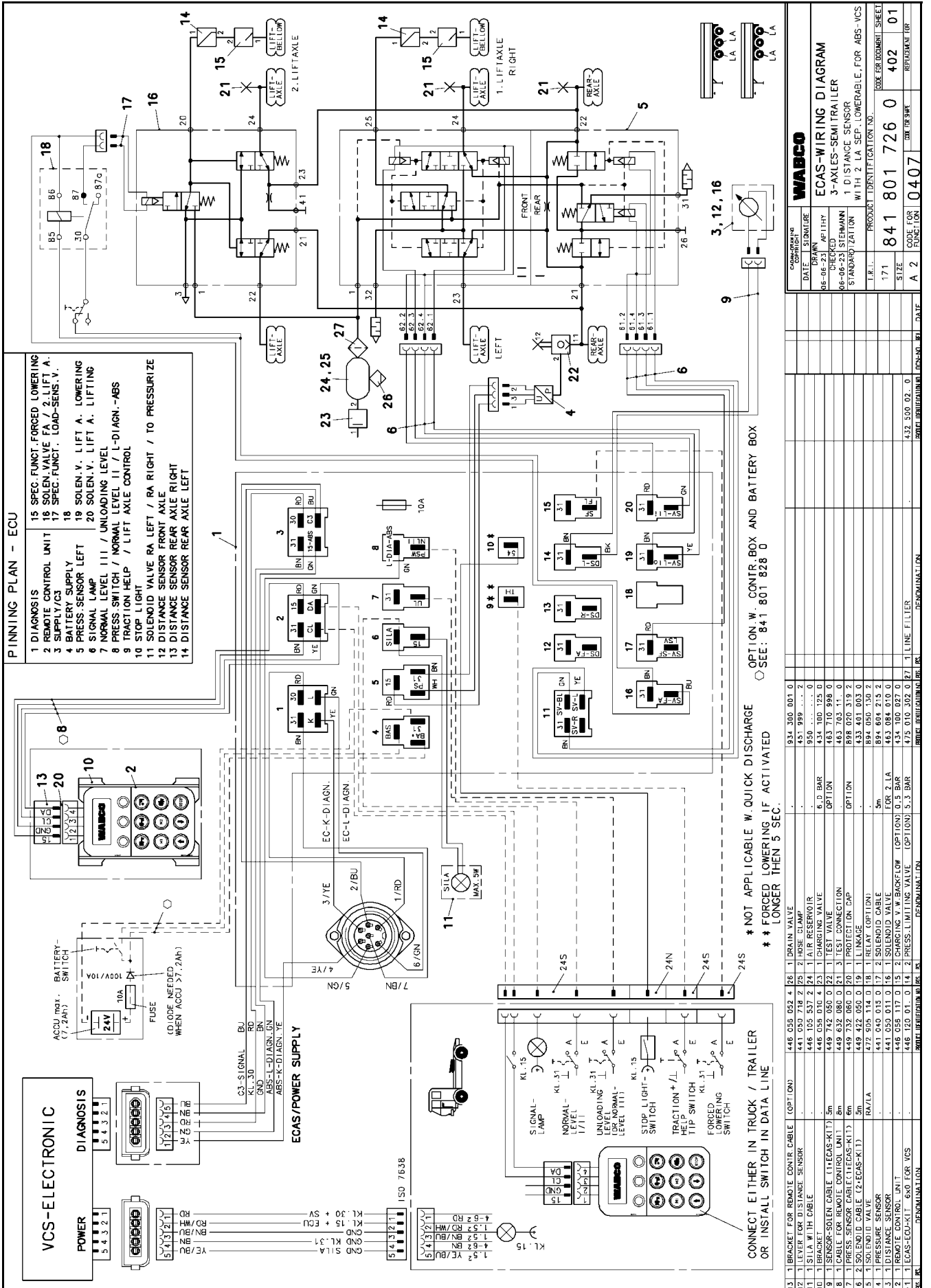

List of Parameters Trailer ECAS

ECU Variant: 446 055 065 0

Circuit Diagram No.: 841 801 727 0

Parameter Record No.: 8418017270

Par.	=	Value	Unit
P 0	=	18	
P 1	=	16	
P 2	=	13	
P 3	=	84	
P 4	=	5	
P 5	=	0	counts
P 6	=	160	counts
P 7	=	0	counts
P 8	=	115	counts
P 9	=	0	counts
P10	=	5	counts
P11	=	255	counts
P12	=	255	counts
P13	=	255	counts
P14	=	20	counts
P15	=	15	k.p.h.
P16	=	8	250ms
P17	=	12	25ms
P18	=	80	250ms
P19	=	0	1/3counts

Par.	=	Value	Unit
P20	=	10	1/3counts
P21	=	0	1/3counts
P22	=	20	1/3counts
P23	=	0	counts
P24	=	15	counts
P25	=	255	k.p.h.
P26	=	0	k.p.h.
P27	=	240	250ms
P28	=	8	1/16bar
P29	=	4	1/16bar
P30	=	96	1/16bar
P31	=	20	k.p.h.
P32	=	18	5s
P33	=	255	5s
P34	=	0	5s
P35	=	20	k.p.h.
P36	=	30	k.p.h.
P37	=	83	1/16bar
P38	=	4	1/16bar
P39	=	10	counts

Par.	=	Value	Unit
P40	=	120	10s
P41	=	20	k.p.h.
P42	=	0	1/16bar
P43	=	0	1/16bar
P44	=	0	counts
P45	=	0	1/16bar
P46	=	0	1/16bar
P47	=	30	10s
P48	=	48	15min
P49	=	10	counts
P50	=	100	300ms
P51	=	20	k.p.h.
P52	=	10	counts

System Description:

semitrailer with one height sensor
 no lifting axle control / traction help
 trailing axle as manoeuvring aid on last axle
 trailing axle pressure of 5.2 bar supporting bellows pressure
 starting manoeuvring aid via remote-control unit or rocking switch
 ending manoeuvring aid by pushing Stop button or holding rocking switch down for more than 5 sec. or Vlimit > 30 k.p.
 raising the level by 10 counts when manoeuvring aid is active
 unloading level to buffer when switch has been activated (160 counts)
 raising/lowering from remote-control unit up to calibrated upper value and mechanical stop at bottom
 automatic driving level from 20 k.p.h.
 2 driving levels selectable from remote-control unit
 DL II > DL I
 remote-control unit cleared up to 15 k.p.h.
 2 freely programmable memory levels via remote-control unit
 2 seconds control delay while stationary and 60 seconds when in motion
 power supply from WABCO-ABS-System VCS

bellows pressure laden 4.0 bar

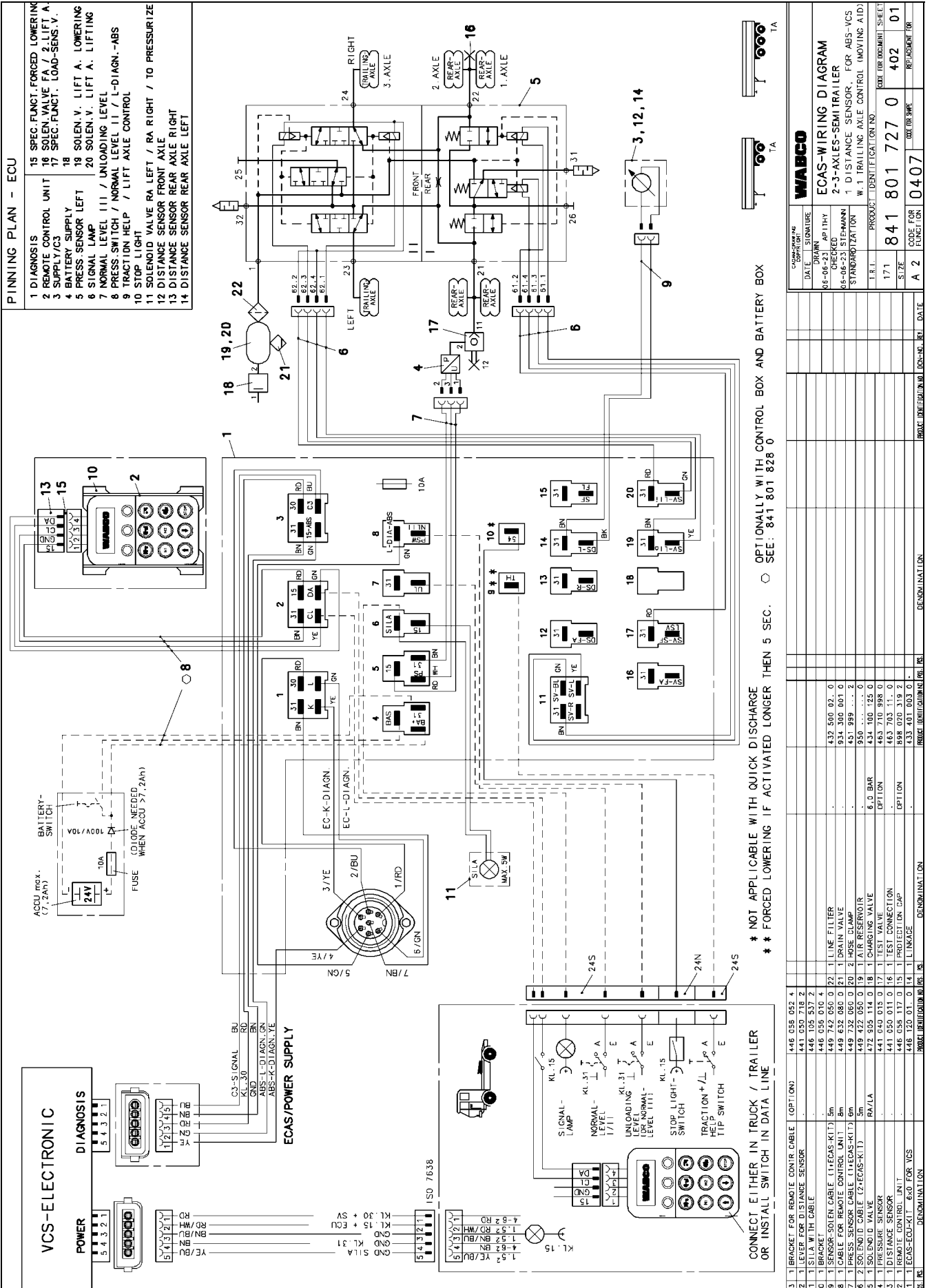

List of Parameters Trailer ECAS

ECU Variant: 446 055 065 0
Circuit Diagram No.: 841 801 728 0
Parameter Record No.: 8418017280

Par.		Value	Unit
P 0	=	18	
P 1	=	30	
P 2	=	13	
P 3	=	116	
P 4	=	0	
P 5	=	15	counts
P 6	=	15	counts
P 7	=	115	counts
P 8	=	115	counts
P 9	=	5	counts
P10	=	5	counts
P11	=	6	counts
P12	=	255	counts
P13	=	15	counts
P14	=	20	counts
P15	=	15	k.p.h.
P16	=	8	250ms
P17	=	12	25ms
P18	=	80	250ms
P19	=	10	1/3counts

Par.		Value	Unit
P20	=	10	1/3counts
P21	=	20	1/3counts
P22	=	20	1/3counts
P23	=	115	counts
P24	=	115	counts
P25	=	255	k.p.h.
P26	=	0	k.p.h.
P27	=	240	250ms
P28	=	0	1/16bar
P29	=	0	1/16bar
P30	=	255	1/16bar
P31	=	0	k.p.h.
P32	=	0	5s
P33	=	0	5s
P34	=	0	5s
P35	=	0	k.p.h.
P36	=	0	k.p.h.
P37	=	0	1/16bar
P38	=	0	1/16bar
P39	=	0	counts

Par.		Value	Unit
P40	=	120	10s
P41	=	20	k.p.h.
P42	=	0	1/16bar
P43	=	0	1/16bar
P44	=	0	counts
P45	=	0	1/16bar
P46	=	0	1/16bar
P47	=	30	10s
P48	=	48	15min
P49	=	10	counts
P50	=	100	300ms
P51	=	0	k.p.h.
P52	=	0	counts

System Description:

drawbar trailer with two height sensors
 no lifting axle control / no traction help
 raising/lowering from remote-control unit up to calibrated upper value and mechanical stop at bottom
 automatic driving level from 20 k.p.h.
 3 driving levels selectable from remote-control unit
 DL III > DL I > DL II
 remote-control unit cleared up to 15 k.p.h.
 2 freely programmable memory levels via remote-control unit
 2 seconds control delay while stationary and 60 seconds when in motion
 power supply from WABCO-ABS-System VCS

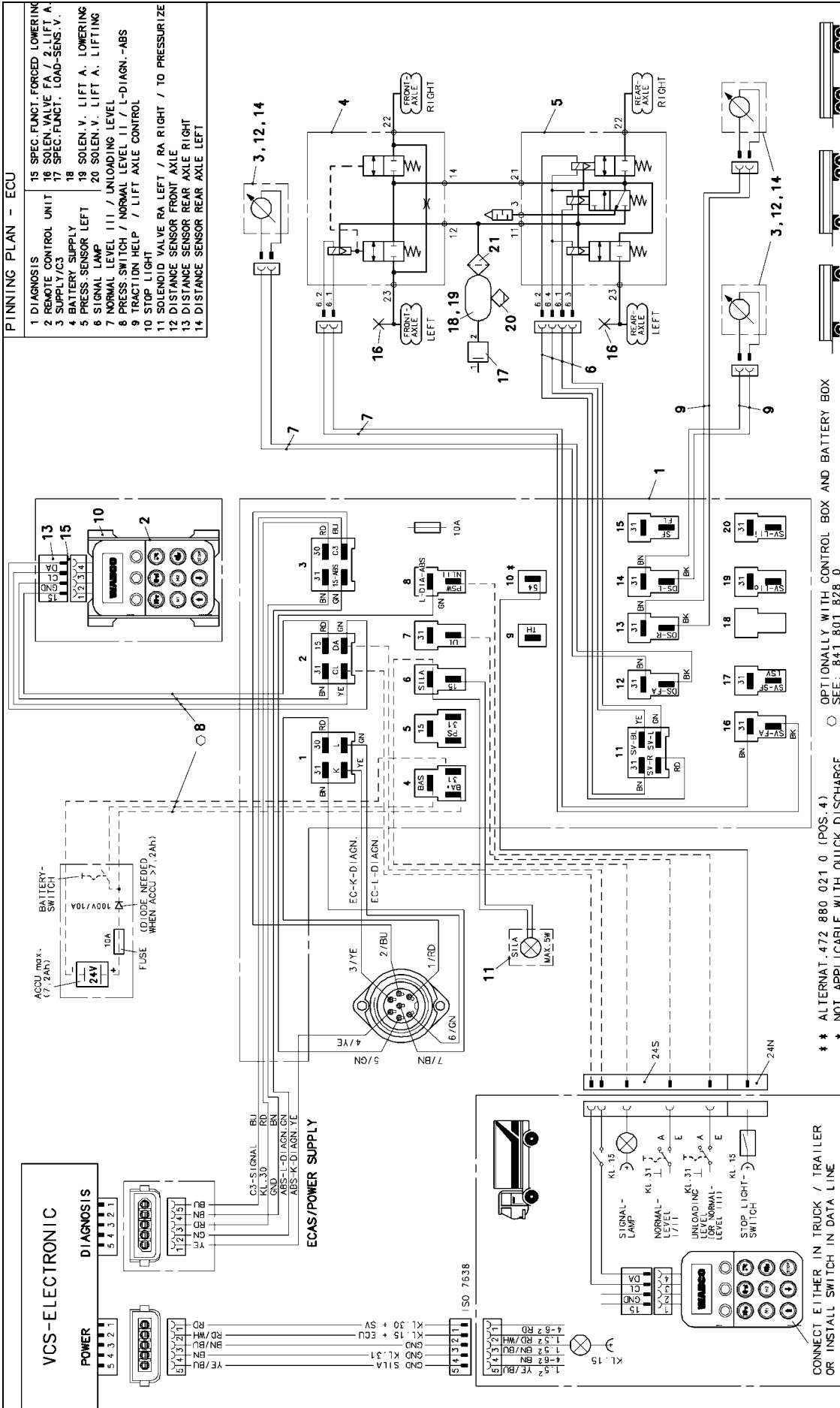

REF. NO.	DENOMINATION	PROTE. IDENTIFICATION NO.	PROTE. IDENTIFICATION NO.	PROTE. IDENTIFICATION NO.	DATE
13	BRACKET FOR REMOTE CONTROL CABLE (OPTION)	446 056 052 4			
12	LEVER FOR DISTANCE SENSOR	441 050 718 2			
11	5 LIA WITH CABLE	446 105 537 2			
10	BRACKET	446 056 070 4			
9	SENSOR-SOLENOID CABLE (1-ECAS-KIT) 5m	449 745 050 0			
8	CABLE FOR REMOTE CONTROL UNIT 5m	449 832 080 0			
7	SOLENOID VALVE RA	449 432 050 0			
6	SOLENOID VALVE RA	449 432 050 0			
5	SOLENOID VALVE RA	449 432 050 0			
4	SOLENOID VALVE FA	449 432 050 0			
3	DISTANCE SENSOR	441 050 011 0			
2	REMOTE CONTROL UNIT	446 056 117 0			
1	1-ECAS-EQU-KIT 6p3 FOR VCS	446 120 011 0			

DATE	DESCRIPTION	BY	DATE
06-06-23	APPROVED		
06-06-23	STANDARDIZATION		
17.1	PROTE. IDENTIFICATION NO.		
841 801 728 0	CODE FOR DOCUMENT SHEET		
A 2	CODE FOR FUNCTION		
10407	CODE FOR PART		

DATE	DESCRIPTION	BY	DATE
06-06-23	APPROVED		
06-06-23	STANDARDIZATION		
17.1	PROTE. IDENTIFICATION NO.		
841 801 728 0	CODE FOR DOCUMENT SHEET		
A 2	CODE FOR FUNCTION		
10407	CODE FOR PART		

WABCO

ECAS-WIRING DIAGRAM
2-3-4 AXLES-TRAILER
3 DISTANCE SENSORS
WITH FA-VALVE FOR ABS-VCS

OPTIONALLY WITH CONTROL BOX AND BATTERY BOX
SEE: 841 801 828 0

** ALTERNAT. 472 880 021 0 (POS. 4)
* NOT APPLICABLE WITH QUICK DISCHARGE

List of Parameters Trailer ECAS

ECU Variant: 446 055 065 0

Circuit Diagram No.: 841 801 729 0

Parameter Record No.: 8418017290

Par.		Value	Unit
P 0	=	18	
P 1	=	2	
P 2	=	13	
P 3	=	244	
P 4	=	5	
P 5	=	15	counts
P 6	=	15	counts
P 7	=	115	counts
P 8	=	115	counts
P 9	=	5	counts
P10	=	5	counts
P11	=	6	counts
P12	=	255	counts
P13	=	15	counts
P14	=	20	counts
P15	=	15	k.p.h.
P16	=	8	250ms
P17	=	12	25ms
P18	=	80	250ms
P19	=	10	1/3counts

Par.		Value	Unit
P20	=	10	1/3counts
P21	=	20	1/3counts
P22	=	20	1/3counts
P23	=	115	counts
P24	=	115	counts
P25	=	255	k.p.h.
P26	=	0	k.p.h.
P27	=	240	250ms
P28	=	64	1/16bar
P29	=	38	1/16bar
P30	=	96	1/16bar
P31	=	20	k.p.h.
P32	=	18	5s
P33	=	255	5s
P34	=	0	5s
P35	=	20	k.p.h./h
P36	=	30	k.p.h.
P37	=	83	1/16bar
P38	=	4	1/16bar
P39	=	10	counts

Par.		Value	Unit
P40	=	120	10s
P41	=	20	k.p.h.
P42	=	0	1/16bar
P43	=	0	1/16bar
P44	=	0	counts
P45	=	0	1/16bar
P46	=	0	1/16bar
P47	=	0	10s
P48	=	48	15min
P49	=	10	counts
P50	=	100	300ms
P51	=	20	k.p.h.
P52	=	10	counts

System Description:

drawbar trailer with three height sensors
 automatic lifting axle control and EC traction help
 lowering of lifting axle at a pressure of 4 bar in the supporting bellows
 raising the lifting axle at a pressure of 2.4 bar in the supporting bellows
 lowering to the buffers due to 50% excess weight at a pressure of 6 bar in the supporting bellows
 traction help pressure of 5.2 bar in the supporting bellows
 starting traction help via remote-control unit or rocking switch
 ending traction help by pushing Stop button or holding rocking switch down for more than 5 sec. or Vlimit > 30 k.p.h.
 lifting axle is lowered after ignition OFF
 lifting axle is raised after vehicle was stopped once and subsequently moved at >20 k.p.h. up to 2.4 bar
 raising the level by 10 counts at driving level for improved tyre clearance when lifting axle is raised
 raising the level by 10 counts when traction help is active
 raising/lowering from remote-control unit up to calibrated upper value and mechanical stop at bottom
 automatic driving level from 20 k.p.h.
 3 driving levels selectable from remote-control unit
 DL III > DL I > DL II
 remote-control unit cleared up to 15 k.p.h.
 2 freely programmable memory levels via remote-control unit
 2 seconds control delay while stationary and 60 seconds when in motion
 power supply from WABCO-ABS-System VCS

bellows pressure laden 4.0 bar

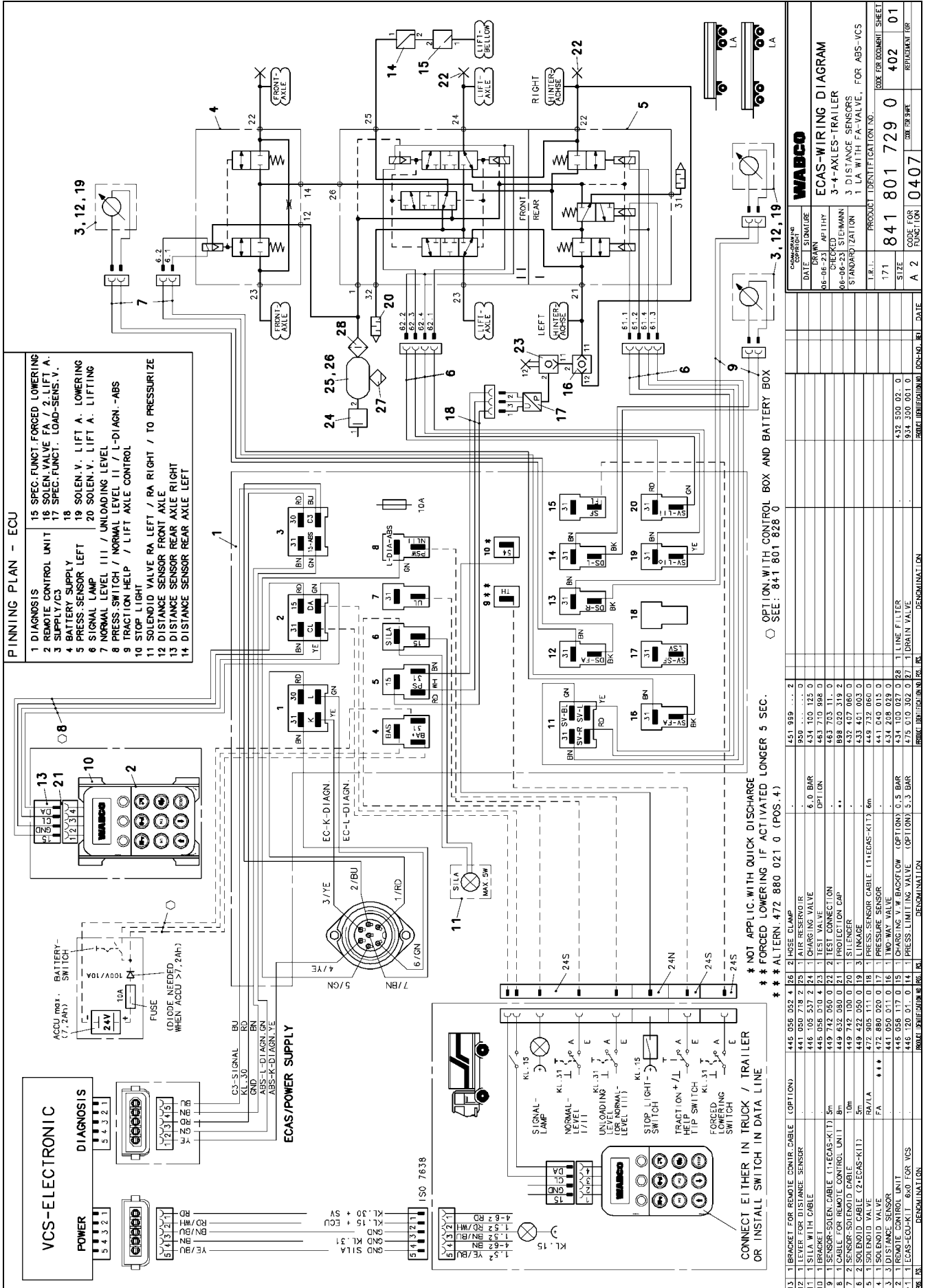

List of Parameters Trailer ECAS

ECU Variant: 446 055 065 0

Circuit Diagram No.: 841 801 730 0

Parameter Record No.: 8418017300

Par.		Value	Unit
P 0	=	18	
P 1	=	16	
P 2	=	13	
P 3	=	84	
P 4	=	5	
P 5	=	0	counts
P 6	=	160	counts
P 7	=	0	counts
P 8	=	115	counts
P 9	=	0	counts
P10	=	5	counts
P11	=	255	counts
P12	=	255	counts
P13	=	255	counts
P14	=	20	counts
P15	=	15	k.p.h.
P16	=	8	250ms
P17	=	12	25ms
P18	=	80	250ms
P19	=	0	1/3counts

Par.		Value	Unit
P20	=	10	1/3counts
P21	=	0	1/3counts
P22	=	20	1/3counts
P23	=	0	counts
P24	=	15	counts
P25	=	255	k.p.h.
P26	=	0	k.p.h.
P27	=	240	250ms
P28	=	64	1/16bar
P29	=	38	1/16bar
P30	=	96	1/16bar
P31	=	20	k.p.h.
P32	=	18	5s
P33	=	255	5s
P34	=	0	5s
P35	=	20	k.p.h.
P36	=	30	k.p.h.
P37	=	83	1/16bar
P38	=	4	1/16bar
P39	=	10	counts

Par.		Value	Unit
P40	=	120	10s
P41	=	20	k.p.h.
P42	=	0	1/16bar
P43	=	0	1/16bar
P44	=	0	counts
P45	=	0	1/16bar
P46	=	0	1/16bar
P47	=	30	10s
P48	=	48	15min
P49	=	10	counts
P50	=	100	300ms
P51	=	20	k.p.h.
P52	=	10	counts

System Description:

semitrailer with one height sensor
 automatic lifting axle control and EC traction help
 lowering of lifting axle at a pressure of 4 bar in the supporting bellows
 raising the lifting axle at a pressure of 2.4 bar in the supporting bellows
 lowering to the buffers due to 50% excess weight at a pressure of 6 bar in the supporting bellows
 traction help pressure of 5.2 bar in the supporting bellows
 starting traction help via remote-control unit or rocking switch
 ending traction help by pushing Stop button or holding rocking switch down for more than 5 sec. or Vlimit > 30 k.p.h.
 lifting axle is lowered after ignition OFF
 lifting axle(s) is (are) raised after vehicle was stopped once and subsequently moved at >20 k.p.h. up to 2.4 bar
 raising the level by 10 counts at driving level for improved tyre clearance when lifting axle is raised
 raising the level by 10 counts when traction help is active
 unloading level to buffer when switch has been activated (160 counts)
 raising/lowering from remote-control unit up to calibrated upper value and mechanical stop at bottom
 automatic driving level from 20 k.p.h.
 2 driving levels selectable from remote-control unit
 DL II > DL I
 remote-control unit cleared up to 15 k.p.h.
 2 freely programmable memory levels via remote-control unit
 2 seconds control delay while stationary and 60 seconds when in motion
 power supply from WABCO-ABS-System VCS

bellows pressure laden 4.0 bar

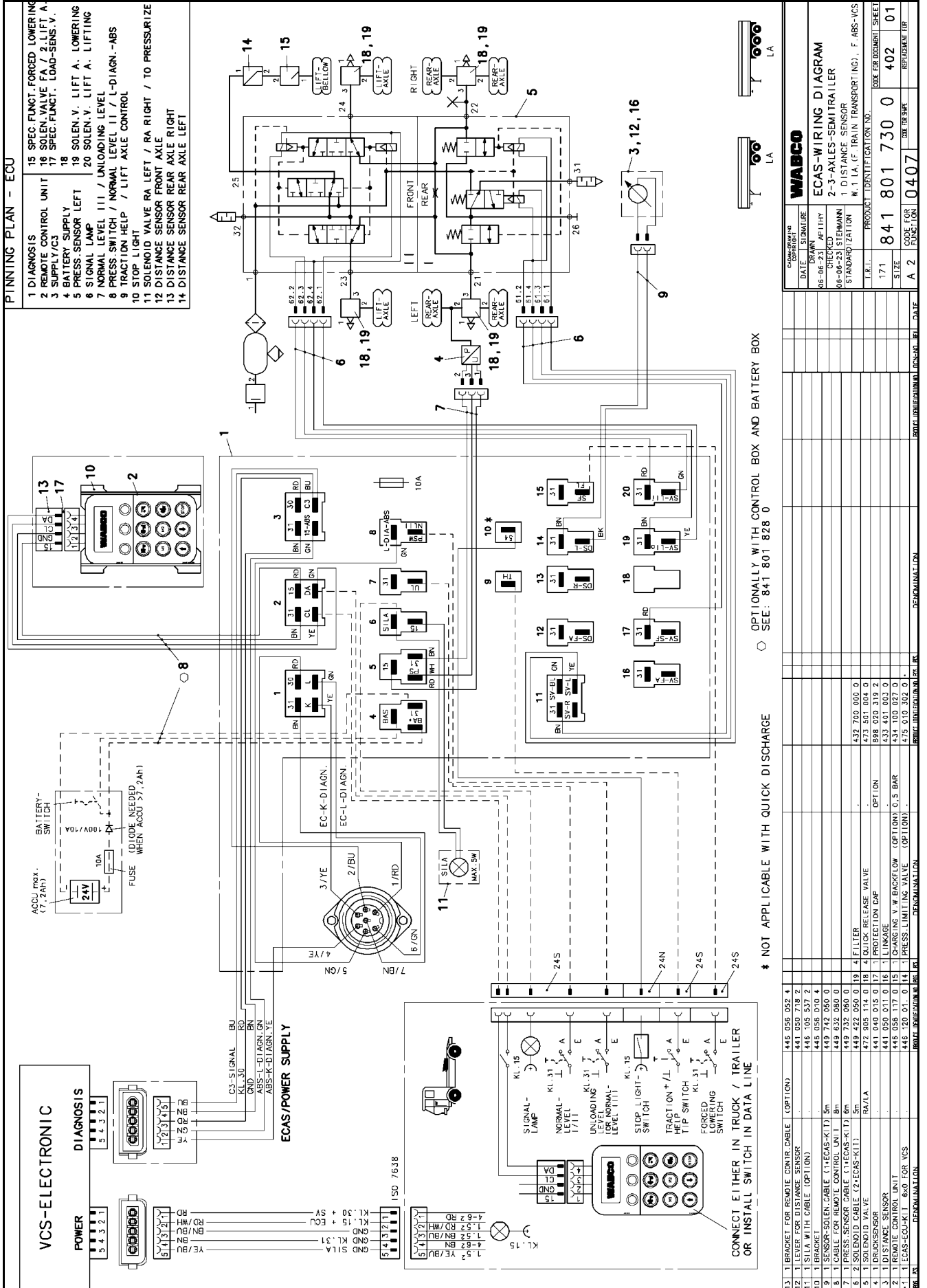

List of Parameters Trailer ECAS

ECU Variant: 446 055 065 0

Circuit Diagram No.: 841 801 731 0

Parameter Record No.: 8418017310

Par.		Value	Unit
P 0	=	18	
P 1	=	16	
P 2	=	13	
P 3	=	84	
P 4	=	5	
P 5	=	0	counts
P 6	=	160	counts
P 7	=	0	counts
P 8	=	115	counts
P 9	=	0	counts
P10	=	5	counts
P11	=	255	counts
P12	=	255	counts
P13	=	255	counts
P14	=	20	counts
P15	=	15	k.p.h.
P16	=	8	250ms
P17	=	12	25ms
P18	=	80	250ms
P19	=	0	1/3counts

Par.		Value	Unit
P20	=	10	1/3counts
P21	=	0	1/3counts
P22	=	20	1/3counts
P23	=	0	counts
P24	=	15	counts
P25	=	255	k.p.h.
P26	=	0	k.p.h.
P27	=	240	250ms
P28	=	8	1/16bar
P29	=	4	1/16bar
P30	=	96	1/16bar
P31	=	20	k.p.h.
P32	=	18	5s
P33	=	255	5s
P34	=	0	5s
P35	=	20	k.p.h.
P36	=	30	k.p.h.
P37	=	83	1/16bar
P38	=	4	1/16bar
P39	=	10	counts

Par.		Value	Unit
P40	=	120	10s
P41	=	20	k.p.h.
P42	=	0	1/16bar
P43	=	0	1/16bar
P44	=	0	counts
P45	=	0	1/16bar
P46	=	0	1/16bar
P47	=	30	10s
P48	=	48	15min
P49	=	10	counts
P50	=	100	300ms
P51	=	20	k.p.h.
P52	=	10	counts

System Description:

- semitrailer with one height sensor
- no lifting axle control
- EC traction help on Axle 1
- lowering to the buffers due to 50% excess weight at a pressure of 6 bar in the supporting bellows
- traction help pressure of 5.2 bar in the supporting bellows
- starting traction help via remote-control unit or rocking switch
- ending traction help by pushing Stop button or holding rocking switch down for more than 5 sec. or Vlimit > 30 k.p.h.
- raising the level by 10 counts when traction help is active
- unloading level to buffer when switch has been activated (160 counts)
- raising/lowering from remote-control unit up to calibrated upper value and mechanical stop at bottom
- automatic driving level from 20 k.p.h.
- 2 driving levels selectable from remote-control unit
- DL II > DL I
- remote-control unit cleared up to 15 k.p.h.
- 2 freely programmable memory levels via remote-control unit
- 2 seconds control delay while stationary and 60 seconds when in motion
- power supply from WABCO-ABS-System VCS

bellows pressure laden 4.0 bar

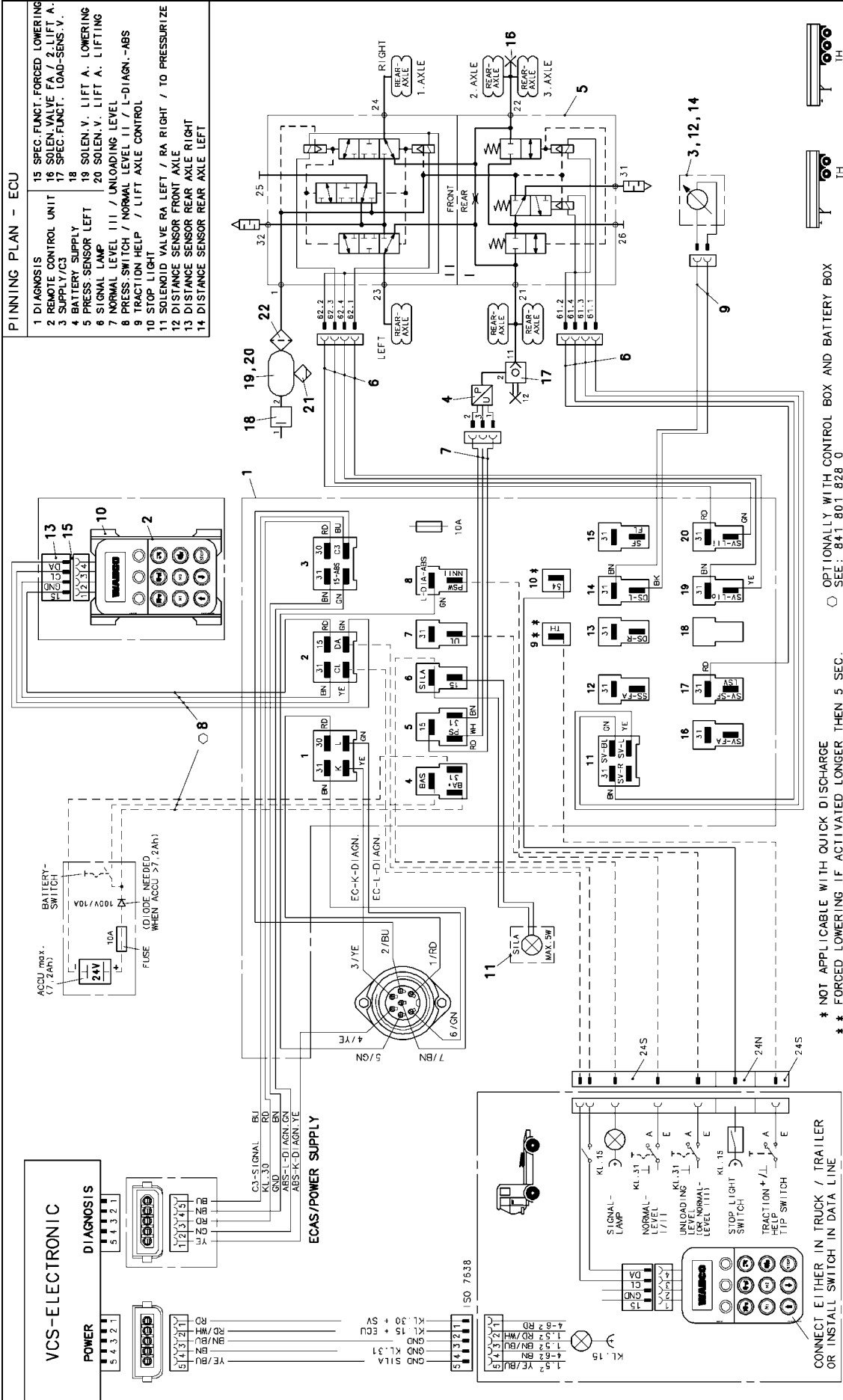

DATE	STATUS	DESCRIPTION
06-06-06	APR THY	CHECKED
06-06-23	STEHRMANN	STANDARDIZATION
171	PRODUCT IDENTIFICATION NO.	
841 801 731 0	SIZE	
A 2	CODE FOR FUNCTION	
0407	REF. DRAWING OR	

NO.	DESCRIPTION	LINKAGE	RENOVATION
31	BRACKET FOR REMOTE CONTROL CABLE (OPTION)	446 056 052 4	
21	LEVER FOR DISTANCE SENSOR	441 030 718 2	
11	SILA WITH CABLE	446 105 537 2	
01	BRACKET	446 056 010 4	
9	SENSOR-SOLENOID CABLE (11ECAS-KIT)	449 742 050 0	21
8	CABLE FOR REMOTE CONTROL UNIT	449 632 080 0	21
7	PRESS. SENSOR CABLE (11ECAS-KIT)	449 732 060 0	20
6	SOLENOID CABLE (21ECAS-KIT)	449 422 050 0	19
5	REAR RESERVOIR	472 005 014 0	15
4	UNLOADING VALVE	441 050 011 0	15
3	DISTANCE SENSOR	446 056 117 0	15
2	REMOTE CONTROL UNIT	448 120 011 0	14
1	ECAS-ECU-KIT 6-20 FOR VCS	443 401 003 0	14

List of Parameters Trailer ECAS

ECU Variant: 446 055 065 0

Circuit Diagram No.: 841 801 732 0

Parameter Record No.: 8418017320

Par.	Value	Unit
P 0	= 18	
P 1	= 20	
P 2	= 9	
P 3	= 116	
P 4	= 0	
P 5	= 0	counts
P 6	= 15	counts
P 7	= 0	counts
P 8	= 115	counts
P 9	= 0	counts
P10	= 5	counts
P11	= 255	counts
P12	= 255	counts
P13	= 255	counts
P14	= 20	counts
P15	= 15	k.p.h.
P16	= 8	250ms
P17	= 12	25ms
P18	= 80	250ms
P19	= 0	1/3counts

Par.	Value	Unit
P20	= 10	1/3counts
P21	= 0	1/3counts
P22	= 20	1/3counts
P23	= 0	counts
P24	= 115	counts
P25	= 70	k.p.h.
P26	= 30	k.p.h.
P27	= 240	250ms
P28	= 0	1/16bar
P29	= 0	1/16bar
P30	= 255	1/16bar
P31	= 0	k.p.h.
P32	= 0	5s
P33	= 0	5s
P34	= 0	5s
P35	= 0	k.p.h.
P36	= 0	k.p.h.
P37	= 0	1/16bar
P38	= 0	1/16bar
P39	= 0	counts

Par.	Value	Unit
P40	= 120	10s
P41	= 20	k.p.h.
P42	= 16	1/16bar
P43	= 64	1/16bar
P44	= 15	counts
P45	= 0	1/16bar
P46	= 0	1/16bar
P47	= 0	10s
P48	= 48	15min
P49	= 10	counts
P50	= 100	300ms
P51	= 0	k.p.h.
P52	= 0	counts

System Description:

semitrailer with one height sensor
 no lifting axle control / traction help
 compensating for tyre deflection for more spring travel when laden
 raising/lowering from remote-control unit up to calibrated upper value and mechanical stop at bottom
 automatic driving level from 20 k.p.h.
 2 driving levels selectable from remote-control unit
 DL III > DL I > DL II
 automatically addressing driving level II at Vlimit > 70 k.p.h.
 returning to driving level 1 when speed falls below Vlimit < 30 k.p.h.
 remote-control unit cleared up to 15 k.p.h.
 2 freely programmable memory levels via remote-control unit
 2 seconds control delay while stationary and 60 seconds when in motion
 power supply from WABCO-ABS-System VCS

bellows pressure laden 4.0 bar

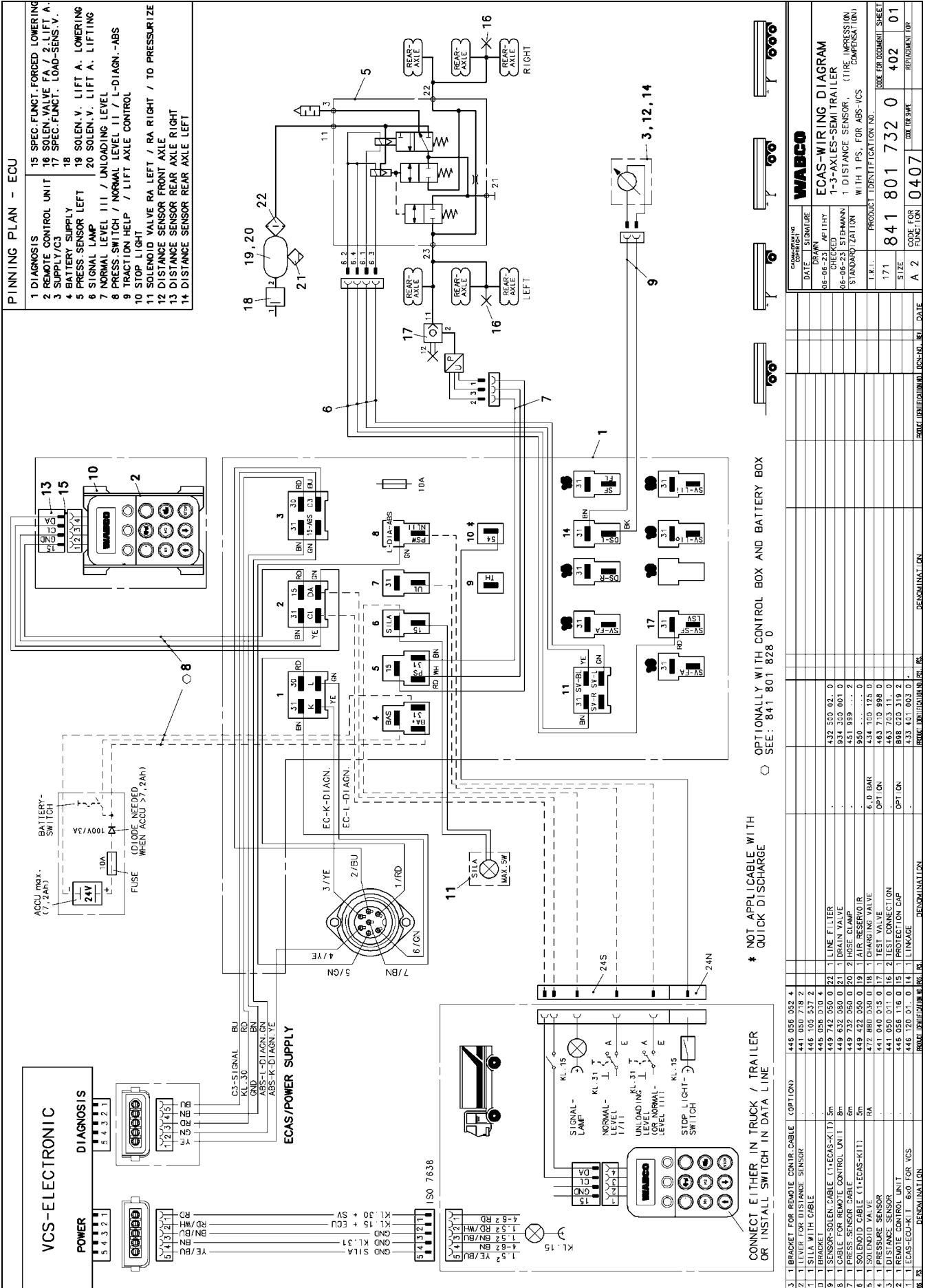

WABCO	
DATE	06-06-11
DRAWN	AS 1114
CHECKED	06-06-23
STANDARDIZATION	WITH T.P.S. FOR ABS-VCS
T.P.S.	PRODUCT IDENTIFICATION NO.
171	841 801 732 0
SIZE	402
CODE FOR REFERENCE	01
CODE FOR REPLACEMENT	0407

NO.	DESCRIPTION	QTY.	REMARKS
1	BRACKET FOR REMOTE CONTROL CABLE (OPTION)	445 056 052 4	
2	1 LEVER FOR DISTANCE SENSOR	441 050 718 2	
3	1 BRACKET WITH CABLE	445 105 537 2	
4	1 BRACKET	445 056 070 4	
5	1 SENSOR-SOLENOID CABLE (1-ECAS-K11)	449 742 050 0 021	1 LINE FILTER
6	1 CABLE FOR REMOTE CONTROL UNIT	449 632 050 0 021	1 DRAIN VALVE
7	1 PRESS. SENSOR CABLE	449 732 050 0 020	2 HOSE CLAMP
8	1 SOLENOID CABLE (1-ECAS-K11)	449 422 050 0 019	1 AIR RESERVOIR
9	1 PRESS. SWITCH	472 600 030 0 019	1 GEAR VALVE
10	1 PRESS. SWITCH	472 600 030 0 019	1 GEAR VALVE
11	1 DISTANCE SENSOR	441 050 011 0 165	2 TEST CONNECTION
12	1 REMOTE CONTROL UNIT	445 058 116 0 151	1 PROTECTION CAP
13	1 ECAS-LOC-K11 6x0 FOR VCS	445 120 071 0 141	1 LINKAGE
14	1 DENOMINATION		

List of Parameters Trailer ECAS

ECU Variant: 446 055 065 0

Circuit Diagram No.: 841 801 733 0

Parameter Record No.: 8418017330

Par.		Value	Unit
P 0	=	18	
P 1	=	0	
P 2	=	77	
P 3	=	212	
P 4	=	5	
P 5	=	0	counts
P 6	=	160	counts
P 7	=	0	counts
P 8	=	115	counts
P 9	=	0	counts
P10	=	5	counts
P11	=	6	counts
P12	=	255	counts
P13	=	255	counts
P14	=	20	counts
P15	=	15	k.p.h.
P16	=	8	250ms
P17	=	12	25ms
P18	=	80	250ms
P19	=	0	1/3counts

Par.		Value	Unit
P20	=	10	1/3counts
P21	=	0	1/3counts
P22	=	20	1/3counts
P23	=	0	counts
P24	=	15	counts
P25	=	255	k.p.h.
P26	=	0	k.p.h.
P27	=	240	250ms
P28	=	64	1/16bar
P29	=	38	1/16bar
P30	=	96	1/16bar
P31	=	20	k.p.h.
P32	=	18	5s
P33	=	255	5s
P34	=	0	5s
P35	=	20	k.p.h.
P36	=	30	k.p.h.
P37	=	83	1/16bar
P38	=	4	1/16bar
P39	=	10	counts

Par.		Value	Unit
P40	=	120	10s
P41	=	20	k.p.h.
P42	=	0	1/16bar
P43	=	0	1/16bar
P44	=	0	counts
P45	=	17	1/16bar
P46	=	25	1/16bar
P47	=	30	10s
P48	=	48	15min
P49	=	10	counts
P50	=	100	300ms
P51	=	20	k.p.h.
P52	=	10	counts

System Description:

semitrailer with two height sensors
automatic lifting axle control for two separate lifting axles and EC traction help on Axle 1
lowering of lifting axle(s) at a pressure of 4 bar in the supporting bellows
raising the first lifting axle at a pressure of 2.4 bar in the supporting bellows
raising the second lifting axle at a pressure of 1.6 bar in the supporting bellows
simultaneously raising both lifting axle up to a pressure of 1.1 bar in the supporting bellows
lowering to the buffers due to 50% excess weight at a pressure of 6 bar in the supporting bellows
traction help pressure of 5.2 bar in the supporting bellows
starting traction help via remote-control unit or rocking switch
ending traction help by pushing Stop button or holding rocking switch down for more than 5 sec. or $V_{\text{limit}} > 30$ k.p.h.
lifting axle is lowered after ignition OFF
lifting axle(s) is (are) raised after vehicle was stopped once and subsequently moved at > 20 k.p.h. up to 2.4 bar
raising the level by 10 counts at driving level for improved tyre clearance when lifting axle is raised
raising the level by 10 counts when traction help is active
unloading level to buffer when switch has been activated (160 counts)
raising/lowering from remote-control unit up to calibrated upper value and mechanical stop at bottom
automatic driving level from 20 k.p.h.
2 driving levels selectable from remote-control unit
DL II > DL I
remote-control unit cleared up to 15 k.p.h.
2 freely programmable memory levels via remote-control unit
2 seconds control delay while stationary and 60 seconds when in motion
power supply from WABCO-ABS-System VCS

bellows pressure laden 4.0 bar

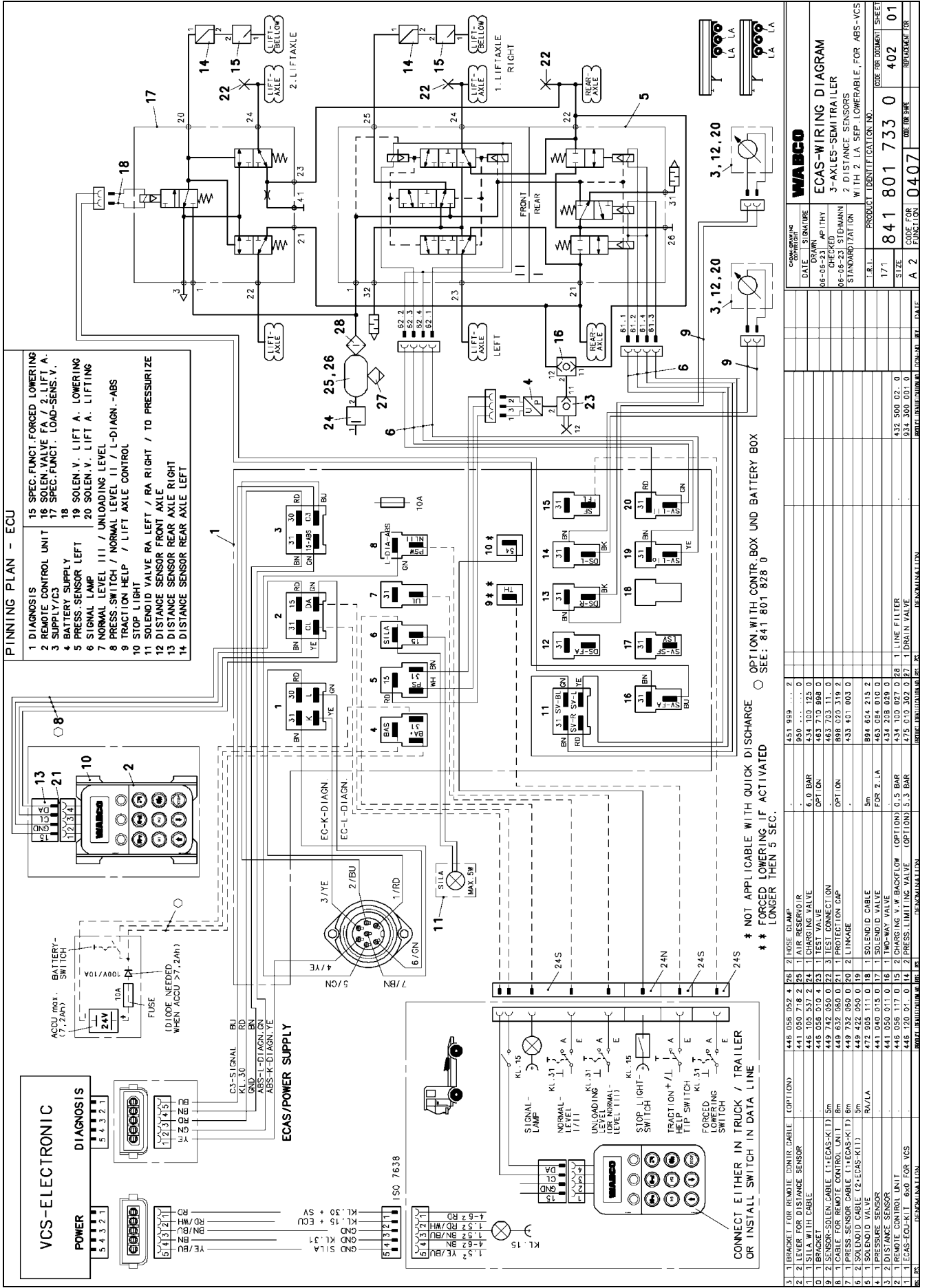

List of Parameters Trailer ECAS

ECU Variant: 446 055 065 0

Circuit Diagram No.: 841 801 734 0

Parameter Record No.: 8418017340

Par.	Value	Unit
P 0	= 18	
P 1	= 50	
P 2	= 13	
P 3	= 212	
P 4	= 5	
P 5	= 160	counts
P 6	= 160	counts
P 7	= 115	counts
P 8	= 115	counts
P 9	= 5	counts
P10	= 5	counts
P11	= 255	counts
P12	= 255	counts
P13	= 255	counts
P14	= 20	counts
P15	= 15	k.p.h.
P16	= 8	250ms
P17	= 12	25ms
P18	= 80	250ms
P19	= 10	1/3counts

Par.	Value	Unit
P20	= 10	1/3counts
P21	= 20	1/3counts
P22	= 20	1/3counts
P23	= 15	counts
P24	= 15	counts
P25	= 255	k.p.h.
P26	= 0	k.p.h.
P27	= 240	250ms
P28	= 64	1/16bar
P29	= 17	1/16bar
P30	= 96	1/16bar
P31	= 20	k.p.h.
P32	= 18	5s
P33	= 255	5s
P34	= 0	5s
P35	= 20	k.p.h.
P36	= 30	k.p.h.
P37	= 83	1/16bar
P38	= 4	1/16bar
P39	= 10	counts

Par.	Value	Unit
P40	= 120	10s
P41	= 20	k.p.h.
P42	= 0	1/16bar
P43	= 0	1/16bar
P44	= 0	counts
P45	= 0	1/16bar
P46	= 0	1/16bar
P47	= 30	10s
P48	= 48	15min
P49	= 10	counts
P50	= 100	300ms
P51	= 20	k.p.h.
P52	= 10	counts

System Description:

semitrailer with two height sensors
automatic lifting axle control for two connected in parallel lifting axles and EC traction help
lowering of lifting axle at a pressure of 4 bar in the supporting bellows
raising the lifting axle at a pressure of 1.1 bar in the supporting bellows
lowering to the buffers due to 50% excess weight at a pressure of 6 bar in the supporting bellows
traction help pressure of 5.2 bar in the supporting bellows
starting traction help via remote-control unit or rocking switch
ending traction help by pushing Stop button or holding rocking switch down for more than 5 sec. or Vlimit > 30 k.p.h.
lifting axle is lowered after ignition OFF
lifting axles are raised after vehicle was stopped once and subsequently moved at >20 k.p.h. up to 1.1 bar
raising the level by 10 counts at driving level for improved tyre clearance when lifting axle is raised
raising the level by 10 counts when traction help is active
unloading level to buffer when switch has been activated (160 counts)
raising/lowering from remote-control unit up to calibrated upper value and mechanical stop at bottom
automatic driving level from 20 k.p.h.
2 driving levels selectable from remote-control unit
DL II > DL I
remote-control unit cleared up to 15 k.p.h.
left/right control of vehicle possible from remote-control unit (raise/lower) (left = front, right = rear)
2 freely programmable memory levels via remote-control unit
2 seconds control delay while stationary and 60 seconds when in motion
power supply from WABCO-ABS-System VCS

bellows pressure laden 4.0 bar

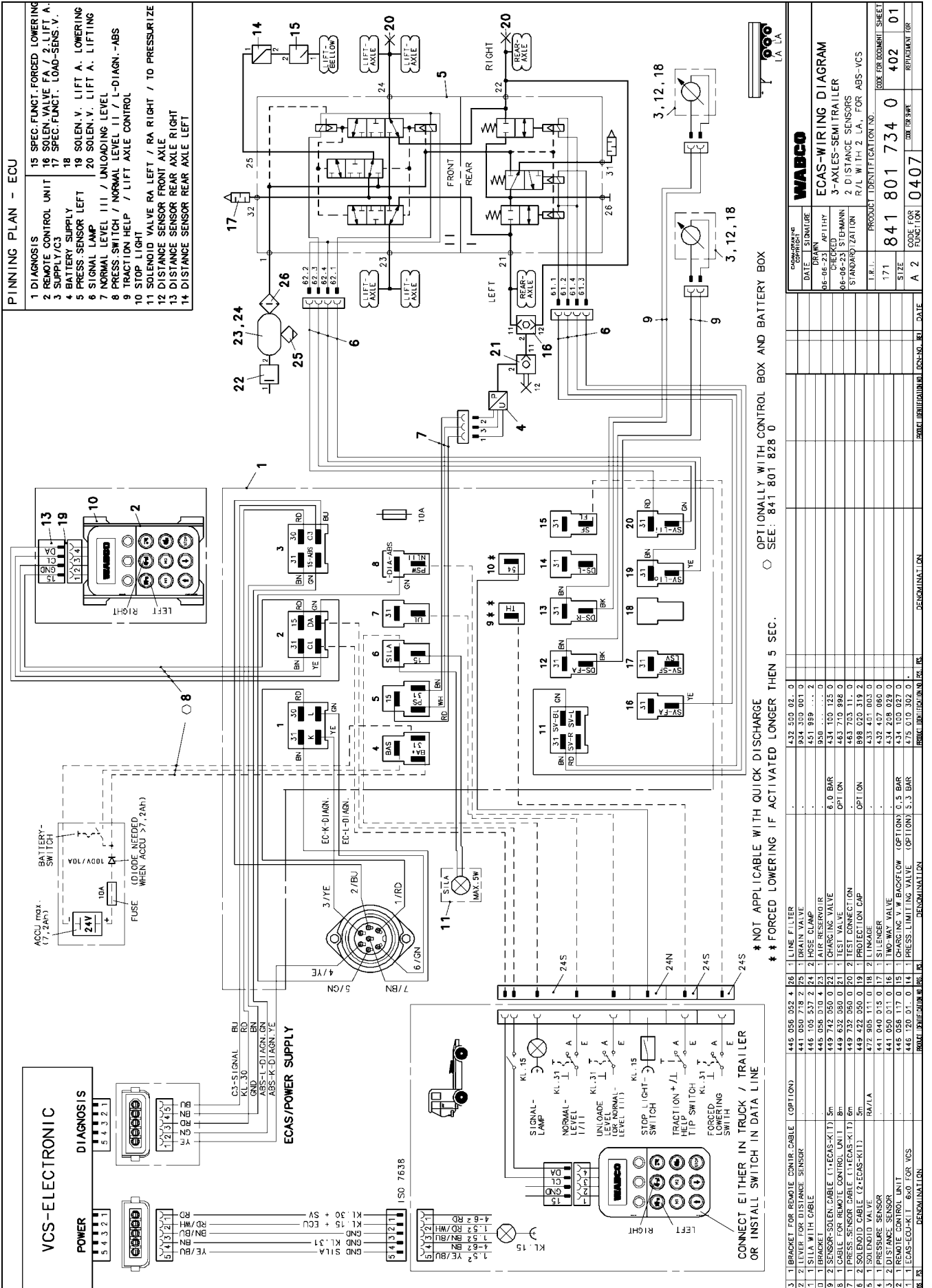

List of Parameters Trailer ECAS

ECU Variant: 446 055 065 0
Circuit Diagram No.: 841 801 735 0
 Parameter Record No.: 8418017350

Par.		Value	Unit
P 0	=	18	
P 1	=	12	
P 2	=	12	
P 3	=	244	
P 4	=	0	
P 5	=	0	counts
P 6	=	15	counts
P 7	=	0	counts
P 8	=	115	counts
P 9	=	0	counts
P10	=	5	counts
P11	=	6	counts
P12	=	255	counts
P13	=	255	counts
P14	=	20	counts
P15	=	15	k.p.h.
P16	=	8	250ms
P17	=	12	25ms
P18	=	80	250ms
P19	=	0	1/3counts

Par.		Value	Unit
P20	=	10	1/3counts
P21	=	0	1/3counts
P22	=	20	1/3counts
P23	=	0	counts
P24	=	115	counts
P25	=	255	k.p.h.
P26	=	0	k.p.h.
P27	=	240	250ms
P28	=	0	1/16bar
P29	=	0	1/16bar
P30	=	255	1/16bar
P31	=	0	k.p.h.
P32	=	0	5s
P33	=	0	5s
P34	=	0	5s
P35	=	0	k.p.h.
P36	=	0	k.p.h.
P37	=	0	1/16bar
P38	=	0	1/16bar
P39	=	0	counts

Par.		Value	Unit
P40	=	120	10s
P41	=	20	k.p.h.
P42	=	0	1/16bar
P43	=	0	1/16bar
P44	=	0	counts
P45	=	0	1/16bar
P46	=	0	1/16bar
P47	=	0	10s
P48	=	48	15min
P49	=	10	counts
P50	=	100	300ms
P51	=	0	k.p.h.
P52	=	0	counts

System Description:

- semitrailer with two height sensors
- no lifting axle control / traction help
- raising/lowering from remote-control unit up to calibrated upper value and mechanical stop at bottom
- automatic driving level from 20 k.p.h.
- 3 driving levels selectable from remote-control unit
- DL III > DL I > DL II
- remote-control unit cleared up to 15 k.p.h.
- 2 freely programmable memory levels via remote-control unit
- 2 seconds control delay while stationary and 60 seconds when in motion
- power supply from WABCO-ABS-System VCS

- PINNING PLAN - ECU**
- 1 DIAGNOSIS
 - 2 REMOTE CONTROL UNIT
 - 3 SUPPLY/C3
 - 4 BATTERY SUPPLY
 - 5 PRESS. SENSOR LEFT
 - 6 SIGNAL LAMP
 - 7 NORMAL LEVEL I/II / UNLOADING LEVEL
 - 8 PRESS. SWITCH / NORMAL LEVEL I/II / L-DIAGN. -ABS
 - 9 TRACTION HELP / LIFT AXLE CONTROL
 - 10 STOP LIGHT
 - 11 SOLENOID VALVE RA LEFT / RA RIGHT / TO PRESSURIZE
 - 12 DISTANCE SENSOR FRONT AXLE
 - 13 DISTANCE SENSOR REAR AXLE RIGHT
 - 14 DISTANCE SENSOR REAR AXLE LEFT
 - 15 SPEC. FUNCT. FORCED LOWERING
 - 16 SOLEN. VALVE FA / 2. LIFT A.
 - 17 SPEC. FUNCT. LOAD-SENS. V.
 - 18
 - 19 SOLEN. V. LIFT A. LOWERING
 - 20 SOLEN. V. LIFT A. LIFTING
 - 21
 - 22
 - 23

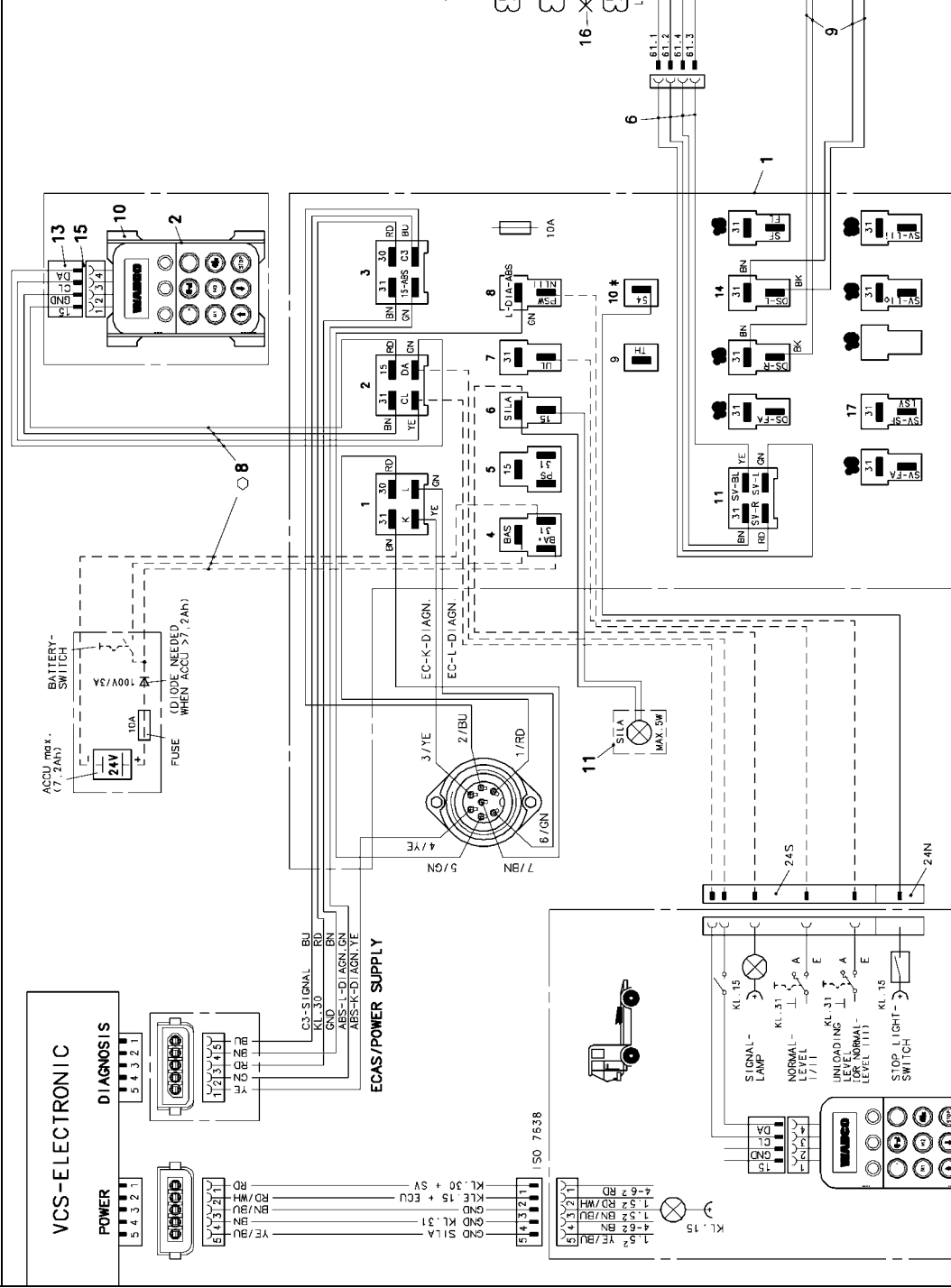

* NOT APPLICABLE WITH OPTIONAL WITH CONTROL BOX AND BATTERY BOX
SEE: 841 801 828 0

DATE		SIGNATURE	
DRAWN BY: THY			
CHECKED: STEHMANN			
STANDARDIZATION: FOR ABS-VCS			
I.T.R.L. PRODUCT IDENTIFICATION NO.		841 801 735 0	
SIZE		402 01	
CODES FOR FUNCTION		0407	

WABCO
ECAS-WIRING DIAGRAM
2-3-AXLES-SEMI TRAILER
FOR ABS-VCS

13	1	BRACKET FOR REMOTE CONTROL CABLE (OPTION)	448 058 052 4
12	2	LEVER FOR DISTANCE SENSOR	441 050 218 2
11	1	SILA WITH CABLE	448 105 537 2
10	1	BRACKET	448 056 010 4
9	2	SENSOR-SOLEN. CABLE (1+ECAS-KIT)	449 742 050 0
8	1	CABLE FOR REMOTE CONTROL UNIT	449 632 080 0
7	1	SOLENOID VALVE	20
6	1	SOLENOID VALVE	449 472 050 0
5	1	SOLENOID VALVE	472 880 001 0
4	1	DRAIN VALVE	441 050 011 0
3	1	DISTANCE SENSOR	448 056 116 0
2	1	REMOTE CONTROL UNIT	888 020 519 2
1	1	ECAS-ECU-KIT 6X0 FOR VCS	448 170 011 0

List of Parameters Trailer ECAS

ECU Variant: 446 055 065 0
Circuit Diagram No.: 841 801 736 0
 Parameter Record No.: 8418017360

Par.		Value	Unit
P 0	=	18	
P 1	=	16	
P 2	=	77	
P 3	=	84	
P 4	=	5	
P 5	=	0	counts
P 6	=	160	counts
P 7	=	0	counts
P 8	=	115	counts
P 9	=	0	counts
P10	=	5	counts
P11	=	255	counts
P12	=	255	counts
P13	=	255	counts
P14	=	20	counts
P15	=	15	k.p.h.
P16	=	8	250ms
P17	=	12	25ms
P18	=	80	250ms
P19	=	0	1/3counts

Par.		Value	Unit
P20	=	10	1/3counts
P21	=	0	1/3counts
P22	=	20	1/3counts
P23	=	0	counts
P24	=	15	counts
P25	=	255	k.p.h.
P26	=	0	k.p.h.
P27	=	240	250ms
P28	=	64	1/16bar
P29	=	38	1/16bar
P30	=	96	1/16bar
P31	=	20	k.p.h.
P32	=	18	5s
P33	=	255	5s
P34	=	0	5s
P35	=	20	k.p.h.
P36	=	30	k.p.h.
P37	=	83	1/16bar
P38	=	4	1/16bar
P39	=	10	counts

Par.		Value	Unit
P40	=	120	10s
P41	=	20	k.p.h.
P42	=	0	1/16bar
P43	=	0	1/16bar
P44	=	0	counts
P45	=	17	1/16bar
P46	=	25	1/16bar
P47	=	30	10s
P48	=	48	15min
P49	=	10	counts
P50	=	100	300ms
P51	=	20	k.p.h.
P52	=	10	counts

System Description:

- semitrailer with one height sensor
- automatic lifting axle control for two separate lifting axles and EC traction help on Axle 1
- lowering of lifting axle(s) at a pressure of 4 bar in the supporting bellows
- raising the first lifting axle at a pressure of 2.4 bar in the supporting bellows
- raising the second lifting axle at a pressure of 1.6 bar in the supporting bellows
- simultaneously raising both lifting axle up to a pressure of 1.1 bar in the supporting bellows
- lowering to the buffers due to 50% excess weight at a pressure of 6 bar in the supporting bellows
- traction help pressure of 5.2 bar in the supporting bellows
- starting traction help via remote-control unit or rocking switch
- ending traction help by pushing Stop button or holding rocking switch down for more than 5 sec. or Vlimit > 30 k.p.h.
- lifting axle is lowered after ignition OFF
- lifting axle(s) is (are) raised after vehicle was stopped once and subsequently moved at >20 k.p.h. up to 2.4 bar
- raising the level by 10 counts at driving level for improved tyre clearance when lifting axle is raised
- raising the level by 10 counts when traction help is active
- unloading level to buffer when switch has been activated (160 counts)
- raising/lowering from remote-control unit up to calibrated upper value and mechanical stop at bottom
- automatic driving level from 20 k.p.h.
- 2 driving levels selectable from remote-control unit
- DL II > DL I
- remote-control unit cleared up to 15 k.p.h.
- 2 freely programmable memory levels via remote-control unit
- 2 seconds control delay while stationary and 60 seconds when in motion
- power supply from WABCO-ABS-System VCS

bellows pressure laden 4.0 bar

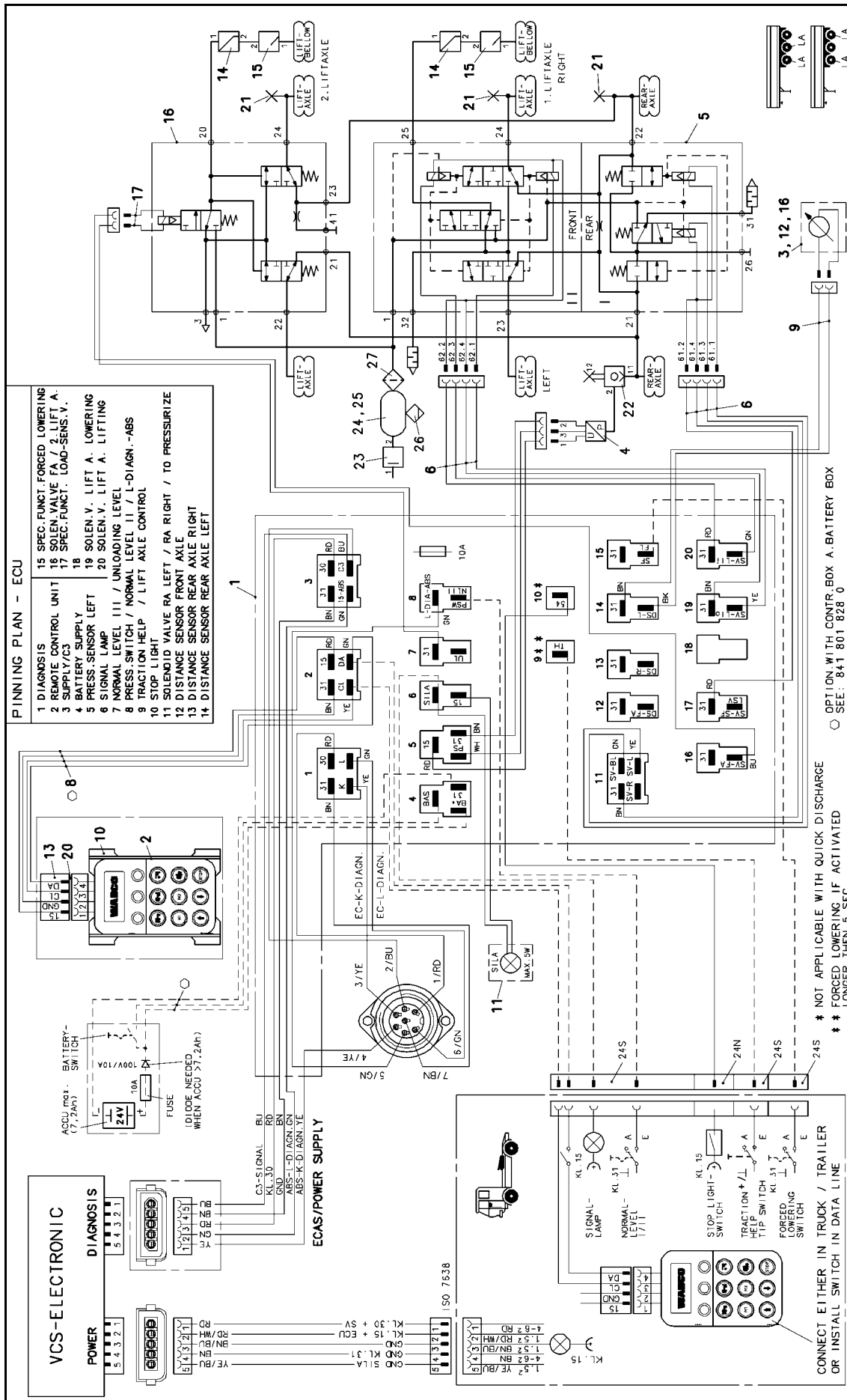

DATE	SIGNATURE	WABCO
86-06-23	DR. M. M. M.	ECAS-WIRING DIAGRAM 3-AXLES-SEMI TRAILER DISTANCE SENSOR WITH 2 LA SEP. LOWERABLE, FOR ABS-VCS
86-06-23	STEINMANN	
STANDARDIZATION		
PRODUCT IDENTIFICATION		
171	841 801 736 0	CODE FOR DOCUMENT SHEET
A	2	SIZE
A	2	CODE FOR PART REFERENCE FOR
		402
		01
		0407

List of Parameters Trailer ECAS

ECU Variant: 446 055 065 0

Circuit Diagram No.: 841 801 737 0

Parameter Record No.: 8418017370

Par.		Value	Unit
P 0	=	18	
P 1	=	62	
P 2	=	13	
P 3	=	244	
P 4	=	0	
P 5	=	15	counts
P 6	=	15	counts
P 7	=	115	counts
P 8	=	115	counts
P 9	=	5	counts
P10	=	5	counts
P11	=	255	counts
P12	=	255	counts
P13	=	255	counts
P14	=	20	counts
P15	=	15	k.p.h.
P16	=	8	250ms
P17	=	12	25ms
P18	=	80	250ms
P19	=	10	1/3counts

Par.		Value	Unit
P20	=	10	1/3counts
P21	=	20	1/3counts
P22	=	20	1/3counts
P23	=	115	counts
P24	=	115	counts
P25	=	255	k.p.h.
P26	=	0	k.p.h.
P27	=	240	250ms
P28	=	0	1/16bar
P29	=	0	1/16bar
P30	=	255	1/16bar
P31	=	0	k.p.h.
P32	=	0	5s
P33	=	0	5s
P34	=	0	5s
P35	=	0	k.p.h.
P36	=	0	k.p.h.
P37	=	0	1/16bar
P38	=	0	1/16bar
P39	=	0	counts

Par.		Value	Unit
P40	=	120	10s
P41	=	20	k.p.h.
P42	=	0	1/16bar
P43	=	0	1/16bar
P44	=	0	counts
P45	=	0	1/16bar
P46	=	0	1/16bar
P47	=	0	10s
P48	=	48	15min
P49	=	10	counts
P50	=	100	300ms
P51	=	0	k.p.h.
P52	=	0	counts

System Description:

semitrailer with two height sensors
 no lifting axle control / traction help
 raising/lowering from remote-control unit up to calibrated upper value and mechanical stop at bottom
 automatic driving level from 20 k.p.h.
 3 driving levels selectable from remote-control unit
 DL III > DL I > DL II
 remote-control unit cleared up to 15 k.p.h.
 left/right control of vehicle possible from remote-control unit (raise/lower)(left = front, right = rear)
 2 freely programmable memory levels via remote-control unit
 2 seconds control delay while stationary and 60 seconds when in motion
 power supply from WABCO-ABS-System VCS

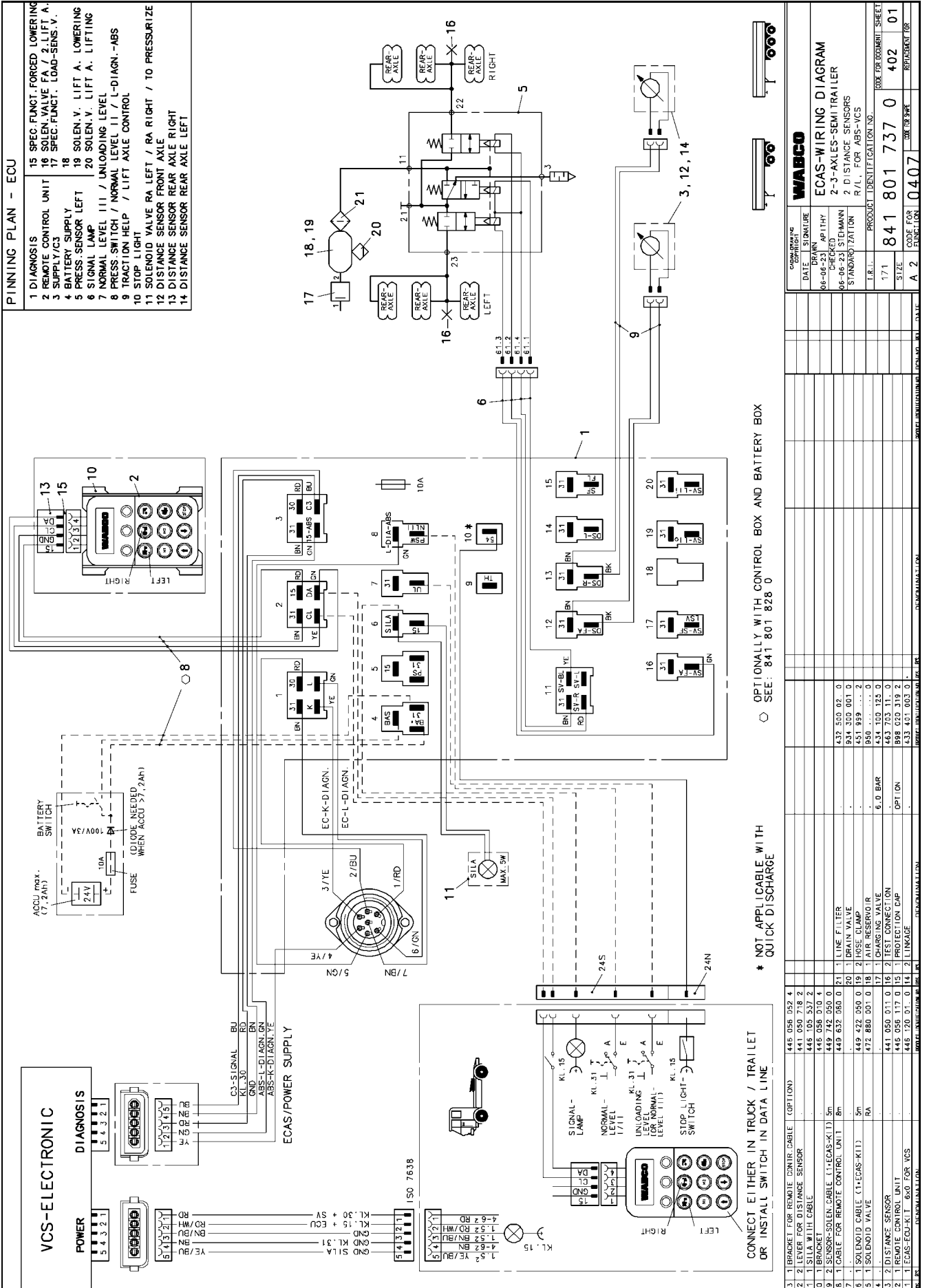

List of Parameters Trailer ECAS

ECU Variant: 446 055 065 0

Circuit Diagram No.: 841 801 738 0

Parameter Record No.: 8418017380

Par.		Value	Unit
P 0	=	18	
P 1	=	18	
P 2	=	13	
P 3	=	116	
P 4	=	5	
P 5	=	15	counts
P 6	=	15	counts
P 7	=	115	counts
P 8	=	115	counts
P 9	=	5	counts
P10	=	5	counts
P11	=	255	counts
P12	=	255	counts
P13	=	15	counts
P14	=	20	counts
P15	=	15	k.p.h.
P16	=	8	250ms
P17	=	12	25ms
P18	=	80	250ms
P19	=	10	1/3counts

Par.		Value	Unit
P20	=	10	1/3counts
P21	=	20	1/3counts
P22	=	20	1/3counts
P23	=	115	counts
P24	=	115	counts
P25	=	255	k.p.h.
P26	=	0	k.p.h.
P27	=	240	250ms
P28	=	64	1/16bar
P29	=	38	1/16bar
P30	=	96	1/16bar
P31	=	20	k.p.h.
P32	=	18	5s
P33	=	255	5s
P34	=	0	5s
P35	=	20	k.p.h.
P36	=	30	k.p.h.
P37	=	83	1/16bar
P38	=	4	1/16bar
P39	=	10	counts

Par.		Value	Unit
P40	=	120	10s
P41	=	20	k.p.h.
P42	=	0	1/16bar
P43	=	0	1/16bar
P44	=	0	counts
P45	=	0	1/16bar
P46	=	0	1/16bar
P47	=	0	10s
P48	=	48	15min
P49	=	10	counts
P50	=	100	300ms
P51	=	20	k.p.h.
P52	=	10	counts

System Description:

drawbar trailer with two height sensors
 automatic lifting axle control and EC traction help
 lowering of lifting axle(s) at a pressure of 4 bar in the supporting bellows
 raising the lifting axle at a pressure of 2.4 bar in the supporting bellows
 lowering to the buffers due to 50% excess weight at a pressure of 6 bar in the supporting bellows
 traction help pressure of 5.2 bar in the supporting bellows
 starting traction help via remote-control unit or rocking switch
 ending traction help by pushing Stop button or holding rocking switch down for more than 5 sec. or Vlimit > 30 k.p.h.
 lifting axle is lowered after ignition OFF
 lifting axle(s) is (are) raised after vehicle was stopped once and subsequently moved at >20 k.p.h. up to 2.4 bar
 raising the level by 10 counts at driving level for improved tyre clearance when lifting axle is raised
 raising the level by 10 counts when traction help is active
 raising/lowering from remote-control unit up to calibrated upper value and mechanical stop at bottom
 automatic driving level from 20 k.p.h.
 3 driving levels selectable from remote-control unit
 DL III > DL I > DL II
 remote-control unit cleared up to 15 k.p.h.
 2 freely programmable memory levels via remote-control unit
 2 seconds control delay while stationary and 60 seconds when in motion
 power supply from WABCO-ABS-System VCS

bellows pressure laden 4.0 bar

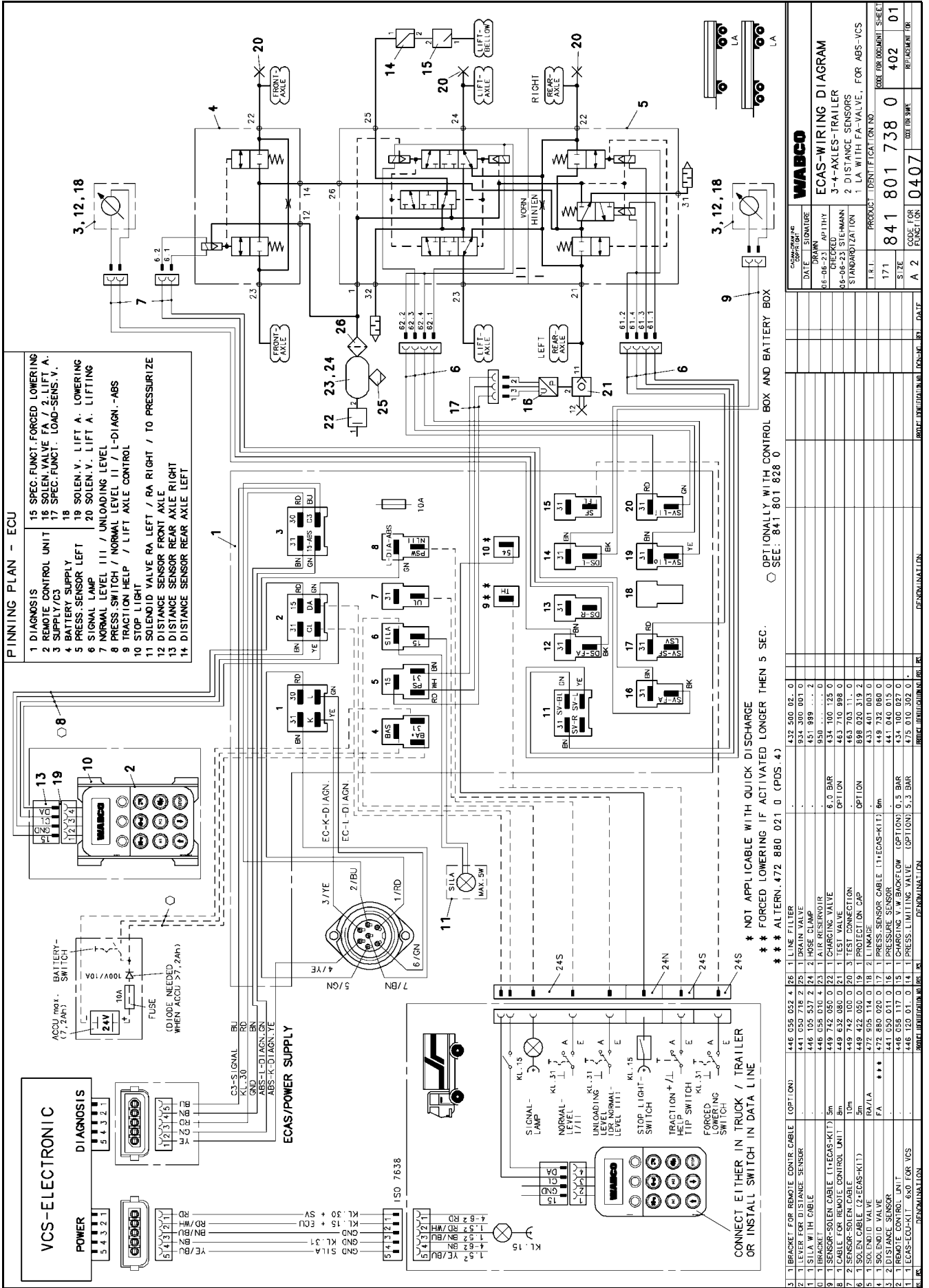

* NOT APPLICABLE WITH QUICK DISCHARGE

** FORCED LOWERING IF ACTIVATED LONGER THEN 5 SEC.

*** ALTERN. 472 880 021 0 (POS. 4)

OPTIONALLY WITH CONTROL BOX AND BATTERY BOX

SEE: 841 801 828 0

List of Parameters Trailer ECAS

ECU Variant: 446 055 065 0

Circuit Diagram No.: 841 801 780 0

Parameter Record No.: 8418017800

Par.	=	Value	Unit
P 0	=	18	
P 1	=	16	
P 2	=	13	
P 3	=	84	
P 4	=	5	
P 5	=	0	counts
P 6	=	160	counts
P 7	=	0	counts
P 8	=	115	counts
P 9	=	0	counts
P10	=	5	counts
P11	=	255	counts
P12	=	255	counts
P13	=	255	counts
P14	=	20	counts
P15	=	15	k.p.h.
P16	=	8	250ms
P17	=	12	25ms
P18	=	80	250ms
P19	=	0	1/3counts

Par.	=	Value	Unit
P20	=	10	1/3counts
P21	=	0	1/3counts
P22	=	20	1/3counts
P23	=	0	counts
P24	=	15	counts
P25	=	255	k.p.h.
P26	=	0	k.p.h.
P27	=	240	250ms
P28	=	64	1/16bar
P29	=	17	1/16bar
P30	=	96	1/16bar
P31	=	20	k.p.h.
P32	=	18	5s
P33	=	255	5s
P34	=	0	5s
P35	=	20	k.p.h.
P36	=	30	k.p.h.
P37	=	83	1/16bar
P38	=	4	1/16bar
P39	=	10	counts

Par.	=	Value	Unit
P40	=	120	10s
P41	=	20	k.p.h.
P42	=	0	1/16bar
P43	=	0	1/16bar
P44	=	0	counts
P45	=	0	1/16bar
P46	=	0	1/16bar
P47	=	30	10s
P48	=	48	15min
P49	=	10	counts
P50	=	100	300ms
P51	=	20	k.p.h.
P52	=	10	counts

System Description:

semitrailer with one height sensor
 automatic lifting axle control for two connected in parallel lifting axles and EC traction help
 lowering of lifting axle(s) at a pressure of 4 bar in the supporting bellows
 raising the lifting axle up to a pressure of 1.1 bar in the supporting bellows
 lowering to the buffers due to 50% excess weight at a pressure of 6 bar in the supporting bellows
 traction help pressure of 5.2 bar in the supporting bellows
 starting traction help via remote-control unit or rocking switch
 ending traction help by pushing Stop button or holding rocking switch down for more than 5 sec. or Vlimit > 30 k.p.h.
 lifting axle is lowered after ignition OFF
 lifting axle(s) is (are) raised after vehicle was stopped once and subsequently moved at >20 k.p.h. up to 1.1 bar
 raising the level by 10 counts at driving level for improved tyre clearance when lifting axle is raised
 raising the level by 10 counts when traction help is active
 unloading level to buffer when switch has been activated (160 counts)
 raising/lowering from remote-control unit up to calibrated upper value and mechanical stop at bottom
 automatic driving level from 20 k.p.h.
 2 driving levels selectable from remote-control unit
 DL II > DL I
 remote-control unit cleared up to 15 k.p.h.
 2 freely programmable memory levels via remote-control unit
 2 seconds control delay while stationary and 60 seconds when in motion
 power supply from WABCO-ABS-System VCS

bellows pressure laden 4.0 bar

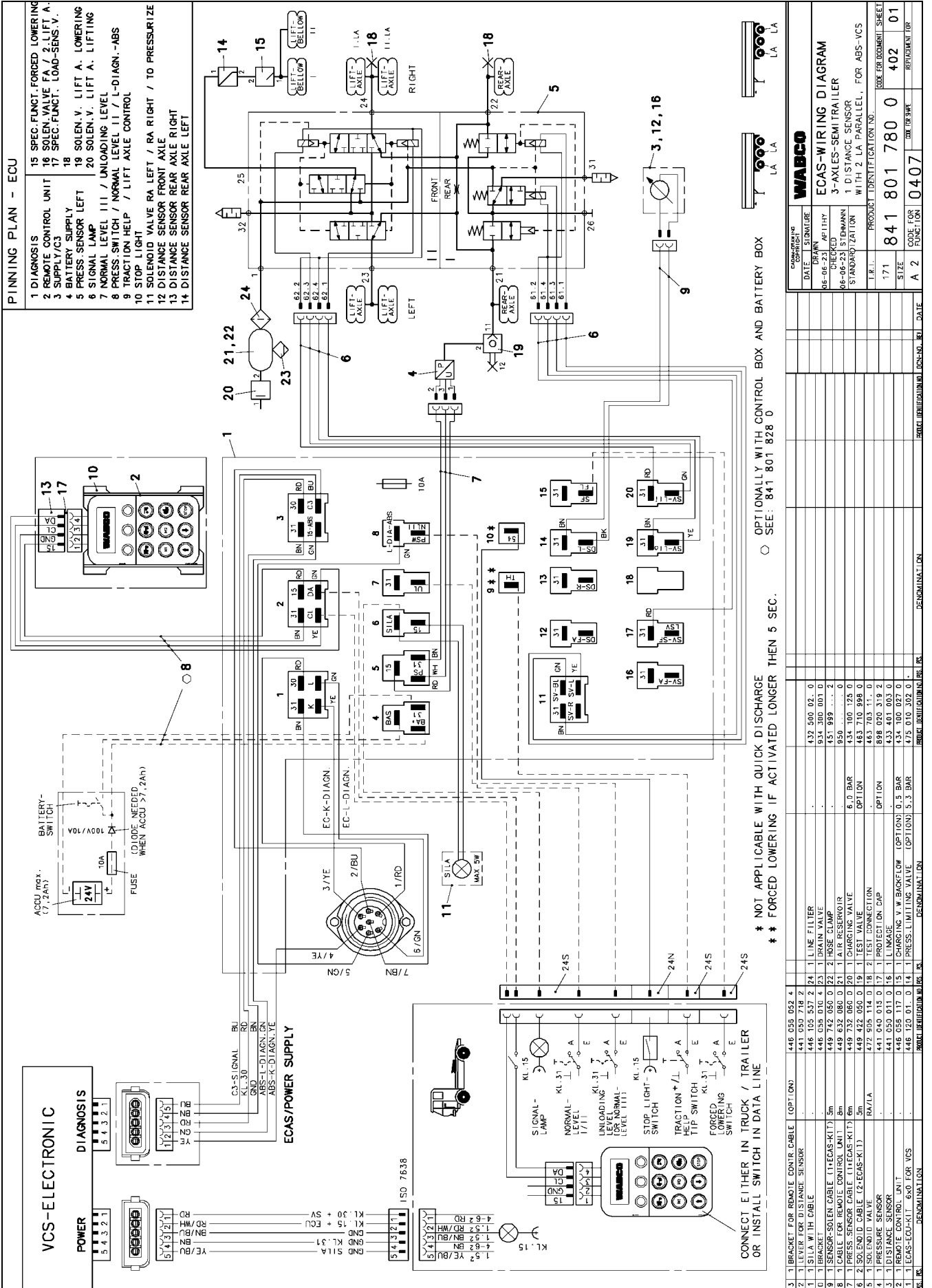

List of Parameters Trailer ECAS

ECU Variant: 446 055 065 0

Circuit Diagram No.: 841 801 781 0

Parameter Record No.: 8418017810

Par.		Value	Unit
P 0	=	18	
P 1	=	30	
P 2	=	13	
P 3	=	116	
P 4	=	0	
P 5	=	15	counts
P 6	=	15	counts
P 7	=	115	counts
P 8	=	115	counts
P 9	=	5	counts
P10	=	5	counts
P11	=	255	counts
P12	=	255	counts
P13	=	15	counts
P14	=	20	counts
P15	=	15	k.p.h.
P16	=	8	250ms
P17	=	12	25ms
P18	=	80	250ms
P19	=	10	1/3counts

Par.		Value	Unit
P20	=	10	1/3counts
P21	=	20	1/3counts
P22	=	20	1/3counts
P23	=	115	counts
P24	=	115	counts
P25	=	255	k.p.h.
P26	=	0	k.p.h.
P27	=	240	250ms
P28	=	0	1/16bar
P29	=	0	1/16bar
P30	=	255	1/16bar
P31	=	0	k.p.h.
P32	=	0	5s
P33	=	0	5s
P34	=	0	5s
P35	=	0	k.p.h.
P36	=	0	k.p.h.
P37	=	0	1/16bar
P38	=	0	1/16bar
P39	=	0	counts

Par.		Value	Unit
P40	=	120	10s
P41	=	20	k.p.h.
P42	=	0	1/16bar
P43	=	0	1/16bar
P44	=	0	counts
P45	=	0	1/16bar
P46	=	0	1/16bar
P47	=	0	10s
P48	=	48	15min
P49	=	10	counts
P50	=	100	300ms
P51	=	0	k.p.h.
P52	=	0	counts

System Description:

drawbar trailer with two height sensors
 no lifting axle control / no traction help
 raising/lowering from remote-control unit up to calibrated upper value and mechanical stop at bottom
 automatic driving level from 20 k.p.h.
 3 driving levels selectable from remote-control unit
 DL III > DL I > DL II
 remote-control unit cleared up to 15 k.p.h.
 2 freely programmable memory levels via remote-control unit
 2 seconds control delay while stationary and 60 seconds when in motion
 no transverse throttle, only 1 solenoid valve, follow pipe lengths/diameters!
 power supply from WABCO-ABS-System VCS

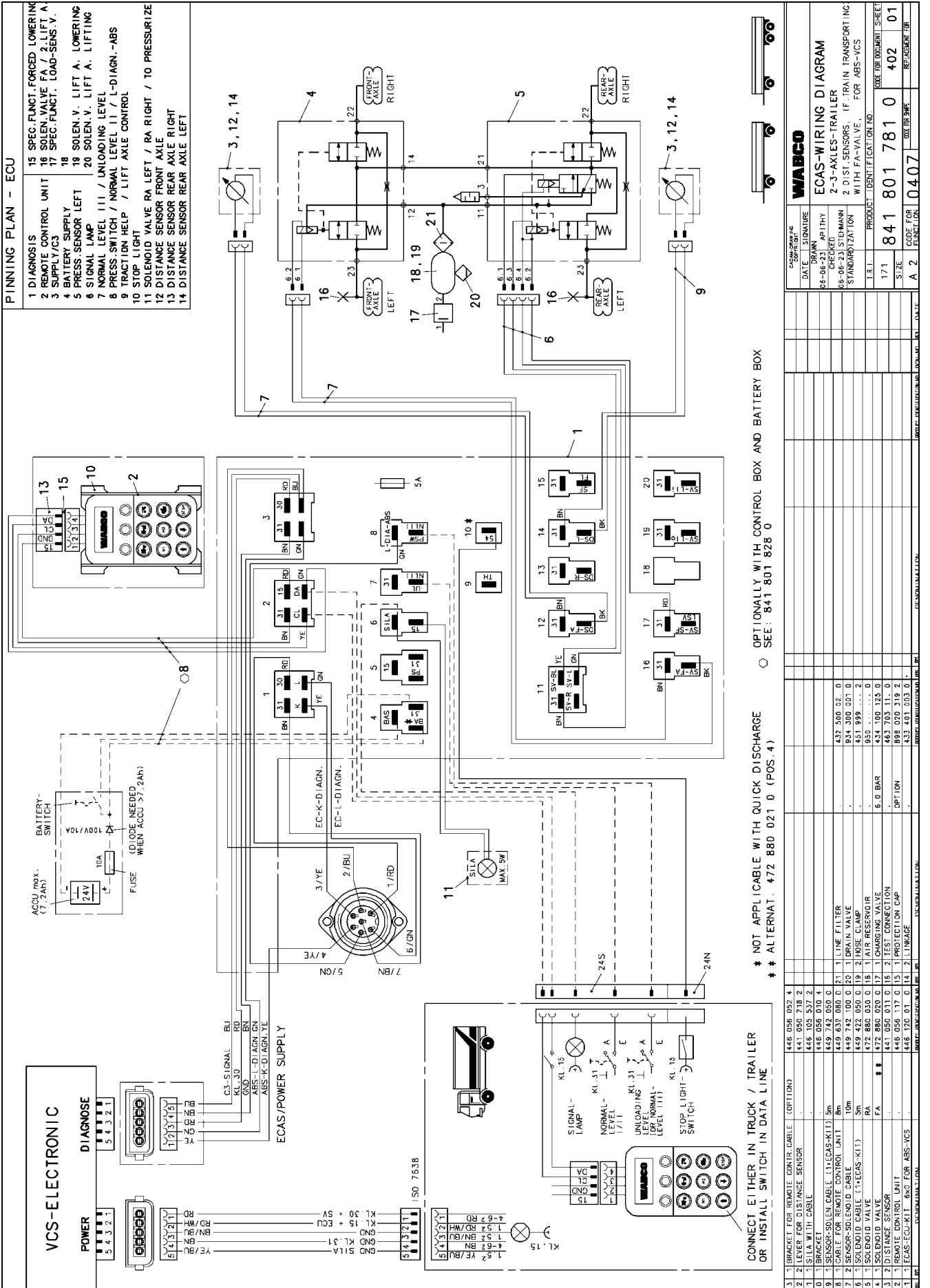

List of Parameters Trailer ECAS

ECU Variant: 446 055 065 0

Circuit Diagram No.: 841 801 782 0

Parameter Record No.: 8418017820

Par.		Value	Unit
P 0	=	18	
P 1	=	4	
P 2	=	9	
P 3	=	244	
P 4	=	0	
P 5	=	0	counts
P 6	=	15	counts
P 7	=	0	counts
P 8	=	115	counts
P 9	=	0	counts
P10	=	5	counts
P11	=	6	counts
P12	=	255	counts
P13	=	255	counts
P14	=	20	counts
P15	=	15	k.p.h.
P16	=	8	250ms
P17	=	12	25ms
P18	=	80	250ms
P19	=	0	1/3counts

Par.		Value	Unit
P20	=	10	1/3counts
P21	=	0	1/3counts
P22	=	20	1/3counts
P23	=	0	counts
P24	=	115	counts
P25	=	70	k.p.h.
P26	=	30	k.p.h.
P27	=	240	250ms
P28	=	0	1/16bar
P29	=	0	1/16bar
P30	=	255	1/16bar
P31	=	0	k.p.h.
P32	=	0	5s
P33	=	0	5s
P34	=	0	5s
P35	=	0	k.p.h.
P36	=	0	k.p.h.
P37	=	0	1/16bar
P38	=	0	1/16bar
P39	=	0	counts

Par.		Value	Unit
P40	=	120	10s
P41	=	20	k.p.h.
P42	=	16	1/16bar
P43	=	64	1/16bar
P44	=	15	counts
P45	=	0	1/16bar
P46	=	0	1/16bar
P47	=	0	10s
P48	=	48	15min
P49	=	10	counts
P50	=	100	300ms
P51	=	20	k.p.h.
P52	=	10	counts

System Description:

semitrailer with two height sensors
 no lifting axle control / traction help
 compensating for tyre deflection for more spring travel when laden
 raising/lowering from remote-control unit up to calibrated upper value and mechanical stop at bottom
 automatic driving level from 20 k.p.h.
 3 driving levels selectable from remote-control unit
 DL III > DL I > DL II
 automatically addressing driving level II at Vlimit > 70 k.p.h.
 returning to driving level 1 when speed falls below Vlimit < 30 k.p.h.
 remote-control unit cleared up to 15 k.p.h.
 2 freely programmable memory levels via remote-control unit
 2 seconds control delay while stationary and 60 seconds when in motion
 power supply from WABCO-ABS-System VCS

bellows pressure laden 4.0 bar

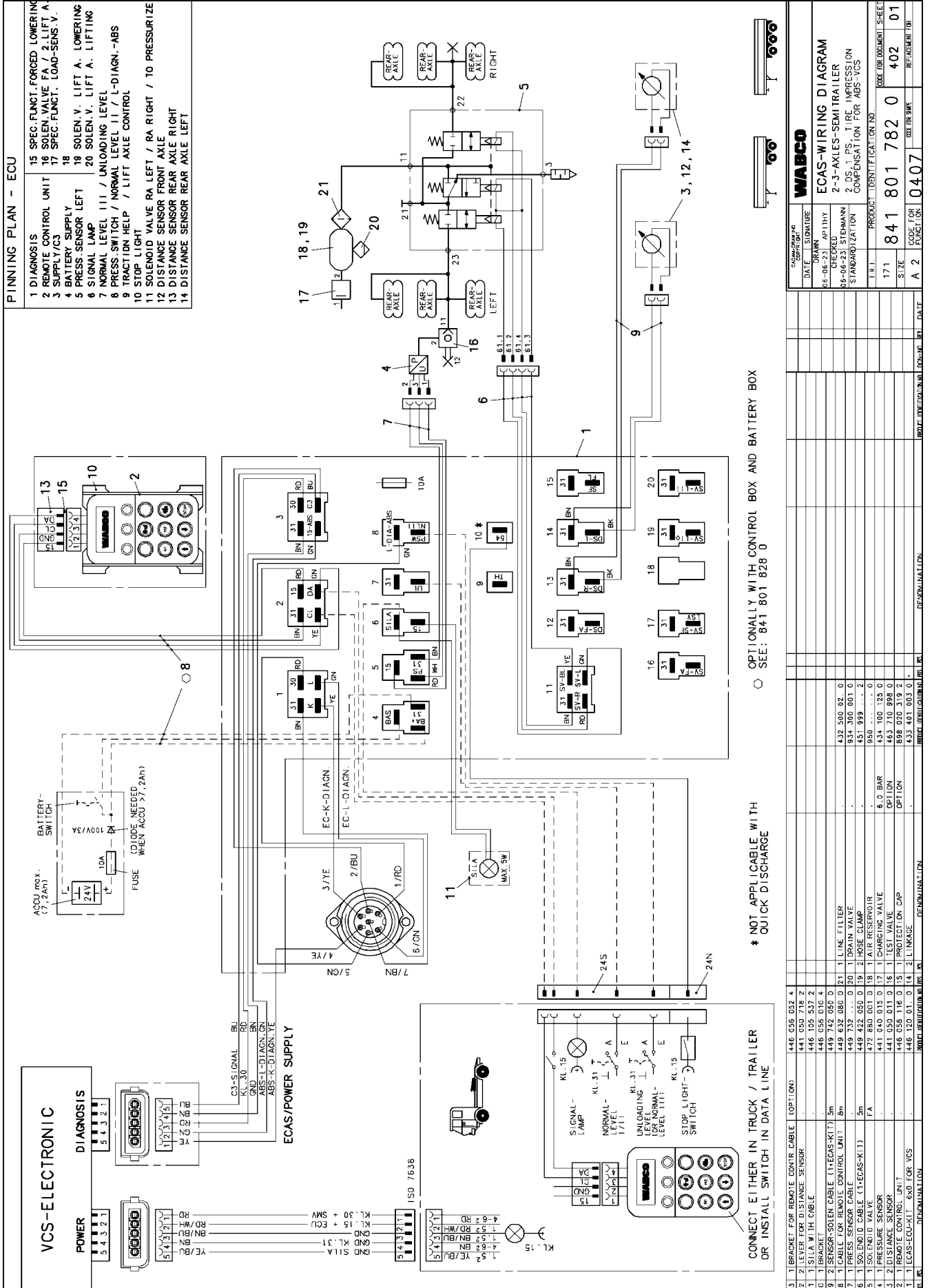

List of Parameters Trailer ECAS

ECU Variant: 446 055 066 0

Circuit Diagram No.: 841 801 750 0

Parameter Record No.: 8418017500

Par.		Value	Unit
P 0	=	18	
P 1	=	30	
P 2	=	13	
P 3	=	124	
P 4	=	0	
P 5	=	15	counts
P 6	=	15	counts
P 7	=	115	counts
P 8	=	115	counts
P 9	=	5	counts
P10	=	5	counts
P11	=	255	counts
P12	=	255	counts
P13	=	15	counts
P14	=	20	counts
P15	=	15	k.p.h.
P16	=	8	250ms
P17	=	12	25ms
P18	=	80	250ms
P19	=	10	1/3counts

Par.		Value	Unit
P20	=	10	1/3counts
P21	=	20	1/3counts
P22	=	20	1/3counts
P23	=	115	counts
P24	=	115	counts
P25	=	255	k.p.h.
P26	=	0	k.p.h.
P27	=	240	250ms
P28	=	0	1/16bar
P29	=	0	1/16bar
P30	=	255	1/16bar
P31	=	0	k.p.h.
P32	=	0	5s
P33	=	0	5s
P34	=	0	5s
P35	=	0	k.p.h.
P36	=	0	k.p.h.
P37	=	0	1/16bar
P38	=	0	1/16bar
P39	=	0	counts

Par.		Value	Unit
P40	=	120	10s
P41	=	20	k.p.h.
P42	=	0	1/16bar
P43	=	0	1/16bar
P44	=	0	counts
P45	=	0	1/16bar
P46	=	0	1/16bar
P47	=	0	10s
P48	=	48	15min
P49	=	10	counts
P50	=	100	300ms
P51	=	0	k.p.h.
P52	=	0	counts

System Description:

drawbar trailer with two height sensors
 no lifting axle control / no traction help
 raising/lowering from remote-control unit up to calibrated upper value and mechanical stop at bottom
 automatic driving level from 20 k.p.h.
 3 driving levels selectable from remote-control unit
 DL III > DL I > DL II
 remote-control unit cleared up to 15 k.p.h.
 2 freely programmable memory levels via remote-control unit
 2 seconds control delay while stationary and 60 seconds when in motion
 power supply from WABCO EBS

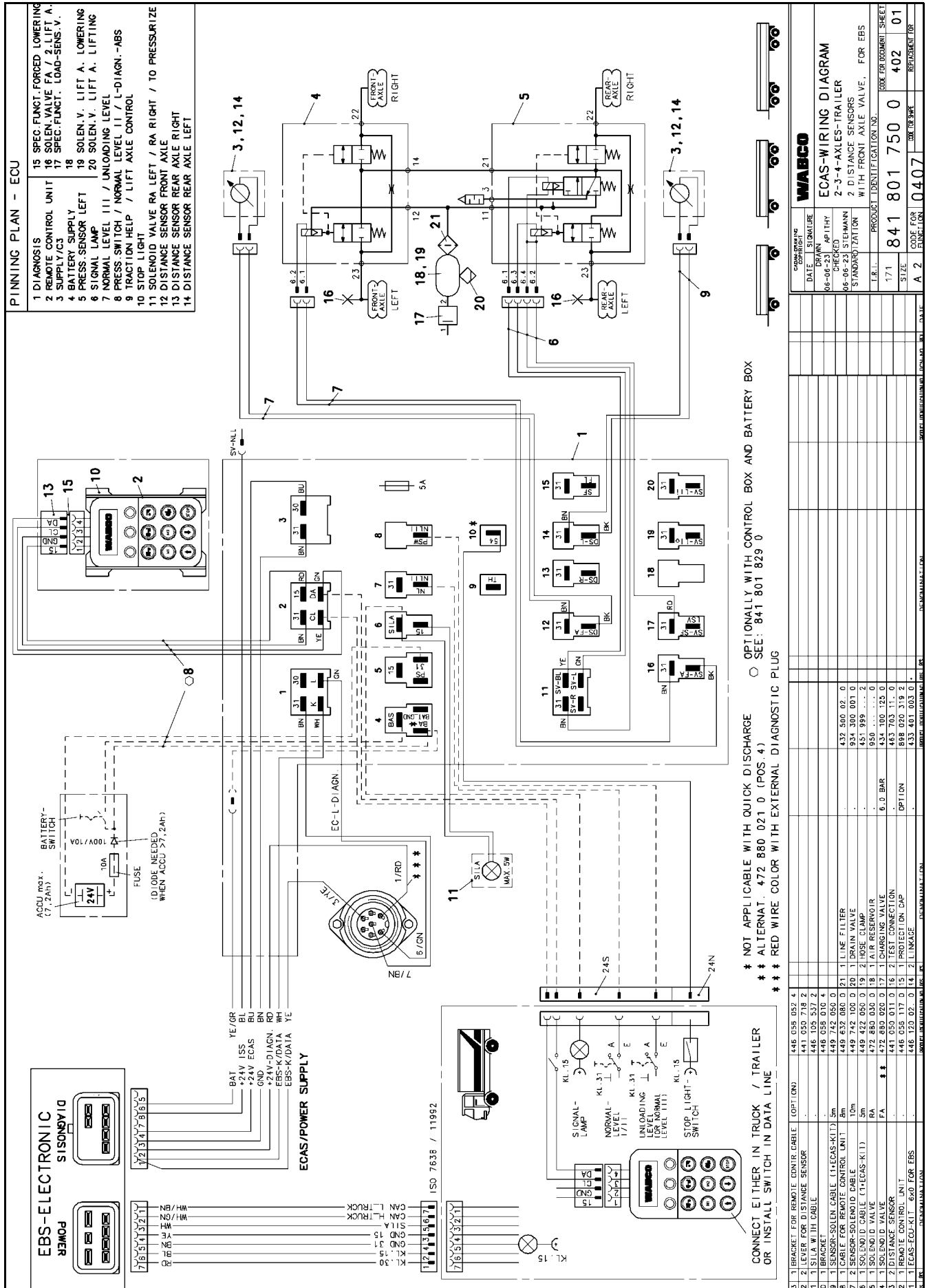

List of Parameters Trailer ECAS

ECU Variant: 446 055 066 0

Circuit Diagram No.: 841 801 751 0

Parameter Record No.: 8418017510

Par.	Value	Unit
P 0	= 18	
P 1	= 30	
P 2	= 13	
P 3	= 124	
P 4	= 0	
P 5	= 15	counts
P 6	= 15	counts
P 7	= 115	counts
P 8	= 115	counts
P 9	= 5	counts
P10	= 5	counts
P11	= 255	counts
P12	= 255	counts
P13	= 15	counts
P14	= 20	counts
P15	= 15	k.p.h.
P16	= 8	250ms
P17	= 12	25ms
P18	= 80	250ms
P19	= 10	1/3counts

Par.	Value	Unit
P20	= 10	1/3counts
P21	= 20	1/3counts
P22	= 20	1/3counts
P23	= 115	counts
P24	= 115	counts
P25	= 255	k.p.h.
P26	= 0	k.p.h.
P27	= 240	250ms
P28	= 0	1/16bar
P29	= 0	1/16bar
P30	= 255	1/16bar
P31	= 0	k.p.h.
P32	= 0	5s
P33	= 0	5s
P34	= 0	5s
P35	= 0	k.p.h.
P36	= 0	k.p.h.
P37	= 0	1/16bar
P38	= 0	1/16bar
P39	= 0	counts

Par.	Value	Unit
P40	= 120	10s
P41	= 20	k.p.h.
P42	= 0	1/16bar
P43	= 0	1/16bar
P44	= 0	counts
P45	= 0	1/16bar
P46	= 0	1/16bar
P47	= 0	10s
P48	= 48	15min
P49	= 10	counts
P50	= 100	300ms
P51	= 0	k.p.h.
P52	= 0	counts

System Description:

Drawbar trailer with two height sensors
 no lifting axle control / no traction help
 raising/lowering from remote-control unit up to calibrated upper value and mechanical stop at bottom
 automatic driving level from 20 k.p.h.
 3 driving levels selectable from remote-control unit
 DL III > DL I > DL II
 remote-control unit cleared up to 15 k.p.h.
 2 freely programmable memory levels via remote-control unit
 2 seconds control delay while stationary and 60 seconds when in motion
 no transverse throttle, only 1 solenoid valve, follow pipe lengths/diameters!
 power supply from WABCO EBS

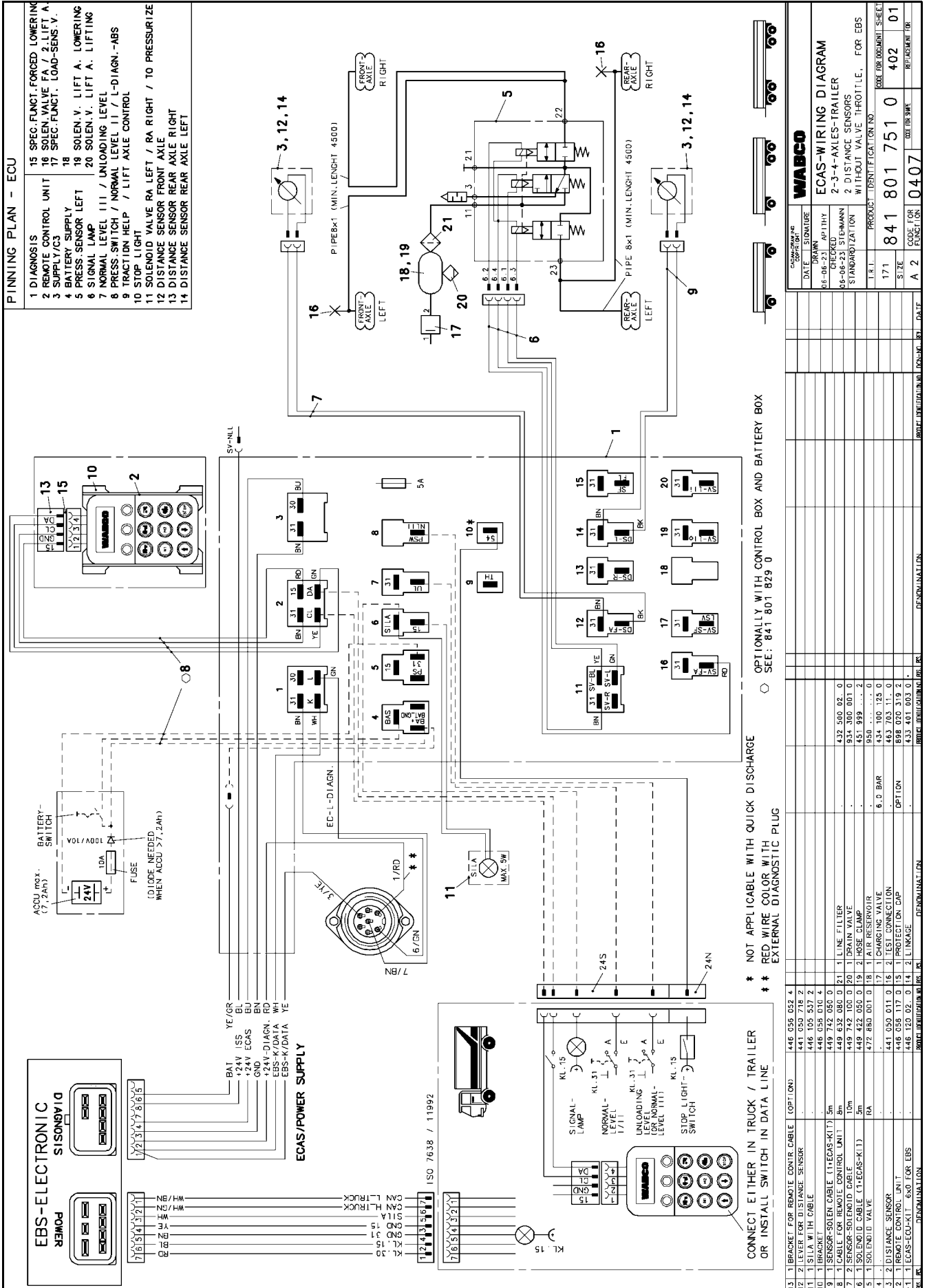

WABCO		ECAS-WIRING DIAGRAM	
DATE	10-06-2011	APPROVED	2-3-4-AXLES-TRAILER
CHECKED	06-06-2011	STANDARDIZATION	2 DISTANCE SENSORS WITHOUT VALVE THROTTLE FOR EBS
PRODUCT IDENTIFICATION NO.	171	CODE FOR DOCUMENT	SHEET
SIZE	A 2	CODE FOR PART	01
REFASSEMBLY	0407		

List of Parameters Trailer ECAS

ECU Variant: 446 055 066 0

Circuit Diagram No.: 841 801 752 0

Parameter Record No.: 8418017520

Par.		Value	Unit
P 0	=	18	
P 1	=	28	
P 2	=	12	
P 3	=	124	
P 4	=	0	
P 5	=	0	counts
P 6	=	15	counts
P 7	=	0	counts
P 8	=	115	counts
P 9	=	0	counts
P10	=	5	counts
P11	=	255	counts
P12	=	255	counts
P13	=	255	counts
P14	=	20	counts
P15	=	15	k.p.h.
P16	=	8	250ms
P17	=	12	25ms
P18	=	80	250ms
P19	=	0	1/3counts

Par.		Value	Unit
P20	=	10	1/3counts
P21	=	0	1/3counts
P22	=	20	1/3counts
P23	=	0	counts
P24	=	115	counts
P25	=	255	k.p.h.
P26	=	0	k.p.h.
P27	=	240	250ms
P28	=	0	1/16bar
P29	=	0	1/16bar
P30	=	255	1/16bar
P31	=	0	k.p.h.
P32	=	0	5s
P33	=	0	5s
P34	=	0	5s
P35	=	0	k.p.h.
P36	=	0	k.p.h.
P37	=	0	1/16bar
P38	=	0	1/16bar
P39	=	0	counts

Par.		Value	Unit
P40	=	120	10s
P41	=	20	k.p.h.
P42	=	0	1/16bar
P43	=	0	1/16bar
P44	=	0	counts
P45	=	0	1/16bar
P46	=	0	1/16bar
P47	=	0	10s
P48	=	48	15min
P49	=	10	counts
P50	=	100	300ms
P51	=	0	k.p.h.
P52	=	0	counts

System Description:

semitrailer with one height sensor
 no lifting axle control / traction help
 raising/lowering from remote-control unit up to calibrated upper value and mechanical stop at bottom
 automatic driving level from 20 k.p.h.
 3 driving levels selectable from remote-control unit
 DL III > DL I > DL II
 remote-control unit cleared up to 15 k.p.h.
 2 freely programmable memory levels via remote-control unit
 2 seconds control delay while stationary and 60 seconds when in motion
 power supply from WABCO EBS

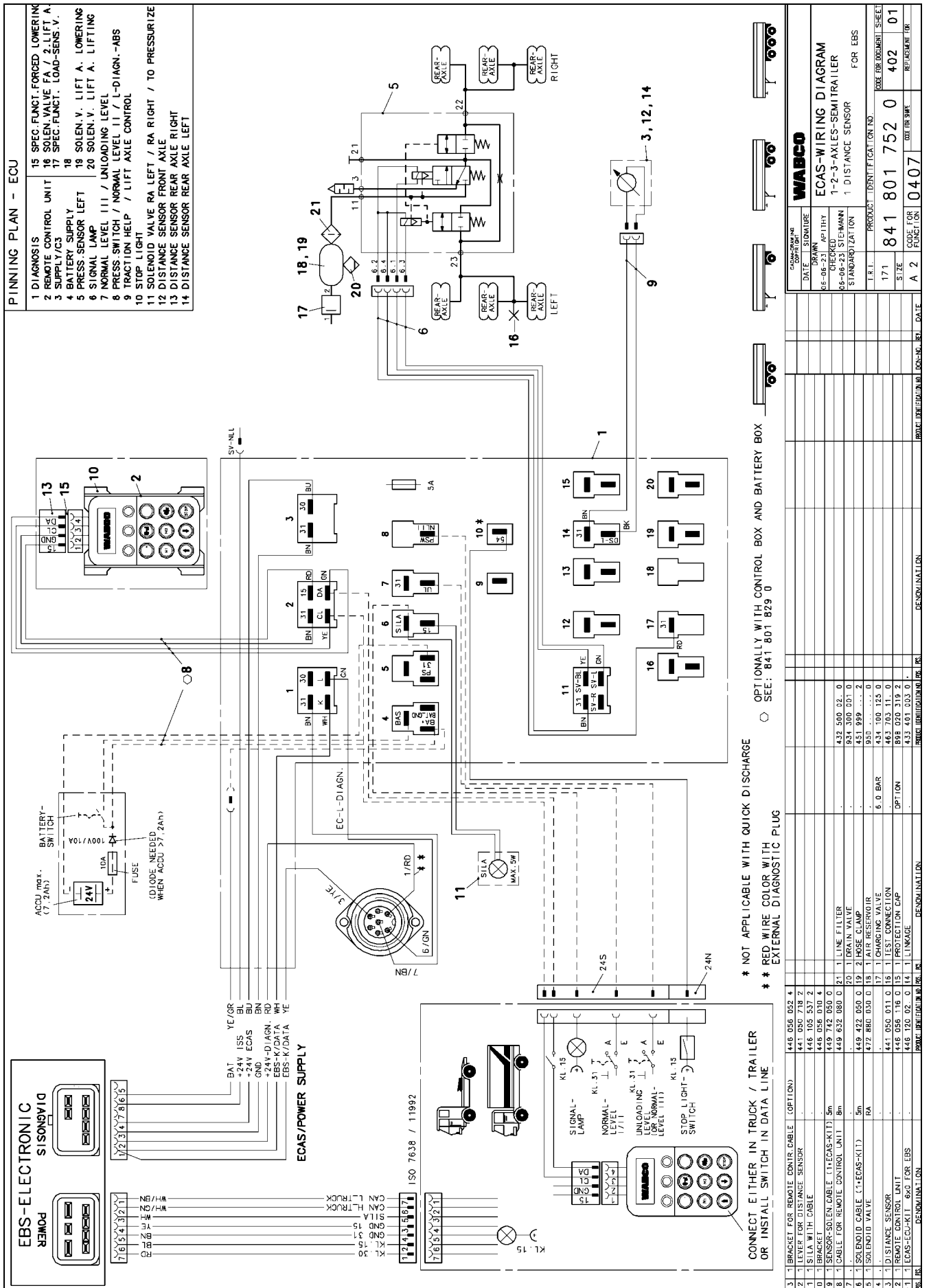

DATE	17.1	SIZE	A 2	CODE FOR FUNCTION	0407
CHECKED	AP THY	DATE FOR DOCUMENT SHEET			
STANDARDIZATION	FOR EBS	PRODUCT IDENTIFICATION NO.			
WABCO					
ECAS-WIRING DIAGRAM					
1-2-3-AXLES-SEMITRAILER					
1 DISTANCE SENSOR					

List of Parameters Trailer ECAS

ECU Variant: 446 055 066 0

Circuit Diagram No.: 841 801 753 0

Parameter Record No.: 8418017530

Par.	Value	Unit
P 0	= 18	
P 1	= 24	
P 2	= 13	
P 3	= 92	
P 4	= 5	
P 5	= 0	counts
P 6	= 160	counts
P 7	= 0	counts
P 8	= 115	counts
P 9	= 0	counts
P10	= 5	counts
P11	= 255	counts
P12	= 255	counts
P13	= 255	counts
P14	= 20	counts
P15	= 15	k.p.h.
P16	= 8	250ms
P17	= 12	25ms
P18	= 80	250ms
P19	= 0	1/3counts

Par.	Value	Unit
P20	= 10	1/3counts
P21	= 0	1/3counts
P22	= 20	1/3counts
P23	= 0	counts
P24	= 15	counts
P25	= 255	k.p.h.
P26	= 0	k.p.h.
P27	= 240	250ms
P28	= 64	1/16bar
P29	= 38	1/16bar
P30	= 96	1/16bar
P31	= 20	k.p.h.
P32	= 18	5s
P33	= 255	5s
P34	= 0	5s
P35	= 20	k.p.h.
P36	= 30	k.p.h.
P37	= 83	1/16bar
P38	= 4	1/16bar
P39	= 10	counts

Par.	Value	Unit
P40	= 120	10s
P41	= 20	k.p.h.
P42	= 0	1/16bar
P43	= 0	1/16bar
P44	= 0	counts
P45	= 0	1/16bar
P46	= 0	1/16bar
P47	= 30	10s
P48	= 48	15min
P49	= 10	counts
P50	= 100	300ms
P51	= 20	k.p.h.
P52	= 10	counts

System Description:

semitrailer with one height sensor
 automatic lifting axle control and EC traction help
 lowering of lifting axle at a pressure of 4 bar in the supporting bellows
 raising the lifting axle up to a pressure of 2.4 bar in the supporting bellows
 lowering to the buffers due to 50% excess weight at a pressure of 6 bar in the supporting bellows
 traction help pressure of 5.2 bar in the supporting bellows
 starting traction help via remote-control unit or rocking switch
 ending traction help by pushing Stop button or holding rocking switch down for more than 5 sec. or Vlimit > 30 k.p.h.
 lifting axle is lowered after ignition OFF
 lifting axle is raised after vehicle was stopped once and subsequently moved at >20 k.p.h. up to 2.4 bar
 raising the level by 10 counts at driving level for improved tyre clearance when lifting axle is raised
 raising the level by 10 counts when traction help is active
 unloading level to buffer when switch has been activated (160 counts)
 raising/lowering from remote-control unit up to calibrated upper value and mechanical stop at bottom
 automatic driving level from 20 k.p.h.
 2 driving levels selectable from remote-control unit
 DL II > DL I
 remote-control unit cleared up to 15 k.p.h.
 2 freely programmable memory levels via remote-control unit
 2 seconds control delay while stationary and 60 seconds when in motion
 power supply from WABCO EBS

bellows pressure laden 4.0 bar

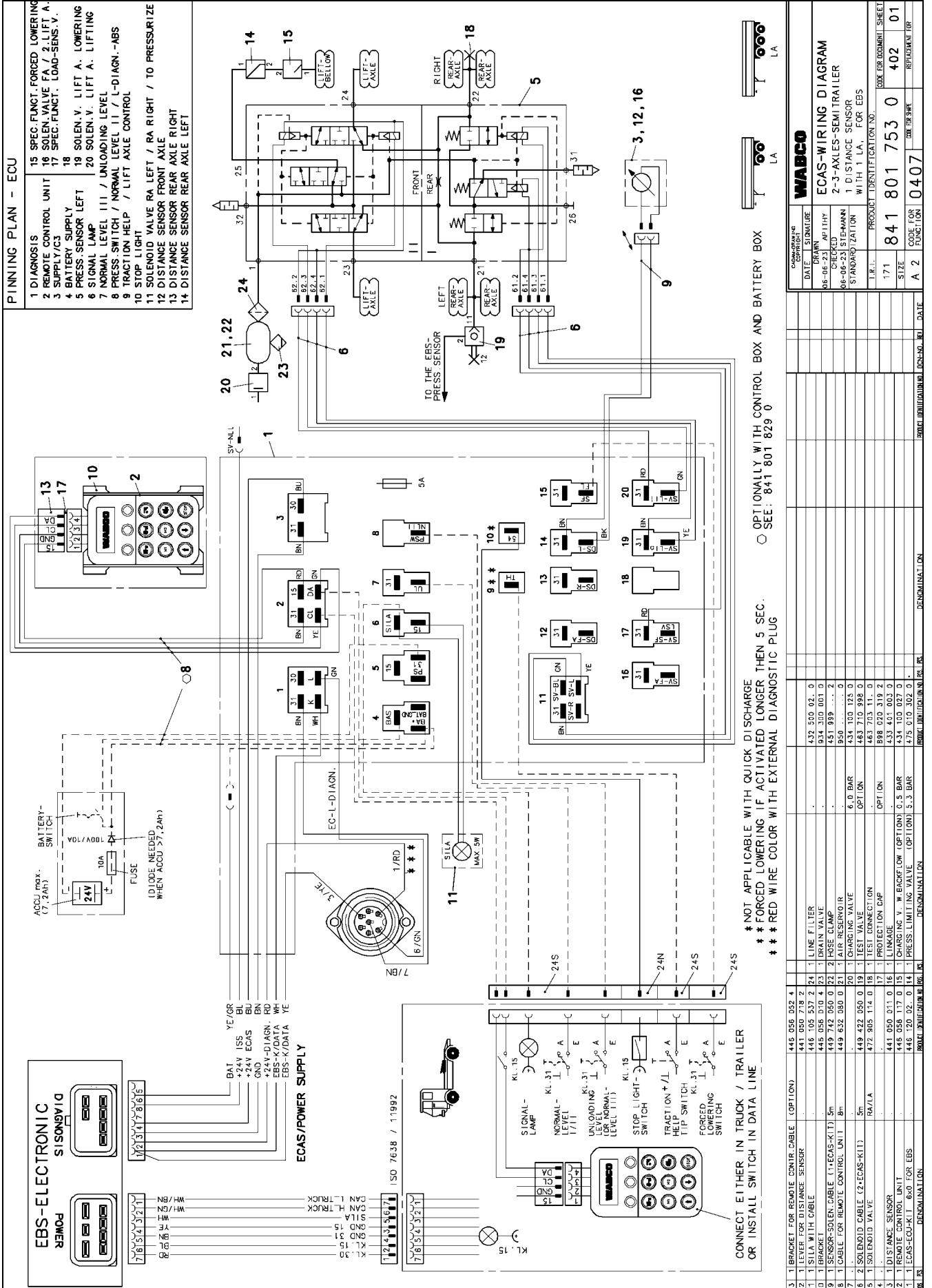

List of Parameters Trailer ECAS

ECU Variant: 446 055 066 0

Circuit Diagram No.: 841 801 754 0

Circuit Diagram No.: 8418017540

Par.	Value	Unit
P 0	= 18	
P 1	= 58	
P 2	= 13	
P 3	= 220	
P 4	= 5	
P 5	= 160	counts
P 6	= 160	counts
P 7	= 115	counts
P 8	= 115	counts
P 9	= 5	counts
P10	= 5	counts
P11	= 255	counts
P12	= 255	counts
P13	= 255	counts
P14	= 20	counts
P15	= 15	k.p.h.
P16	= 8	250ms
P17	= 12	25ms
P18	= 80	250ms
P19	= 10	1/3counts

Par.	Value	Unit
P20	= 10	1/3counts
P21	= 20	1/3counts
P22	= 20	1/3counts
P23	= 15	counts
P24	= 15	counts
P25	= 255	k.p.h.
P26	= 0	k.p.h.
P27	= 240	250ms
P28	= 64	1/16bar
P29	= 38	1/16bar
P30	= 96	1/16bar
P31	= 20	k.p.h.
P32	= 18	5s
P33	= 255	5s
P34	= 0	5s
P35	= 20	k.p.h.
P36	= 30	k.p.h.
P37	= 83	1/16bar
P38	= 4	1/16bar
P39	= 10	counts

Par.	Value	Unit
P40	= 120	10s
P41	= 20	k.p.h.
P42	= 0	1/16bar
P43	= 0	1/16bar
P44	= 0	counts
P45	= 0	1/16bar
P46	= 0	1/16bar
P47	= 30	10s
P48	= 48	15min
P49	= 10	counts
P50	= 100	300ms
P51	= 20	k.p.h.
P52	= 10	counts

System Description:

- semitrailer with two height sensors
- automatic lifting axle control and EC traction help
- lowering of lifting axle at a pressure of 4 bar in the supporting bellows
- raising the lifting axle at a pressure of 2.4 bar in the supporting bellows
- lowering to the buffers due to 50% excess weight at a pressure of 6 bar in the supporting bellows
- traction help pressure of 5.2 bar in the supporting bellows
- starting traction help via remote-control unit or rocking switch
- ending traction help by pushing Stop button or holding rocking switch down for more than 5 sec. or Vlimit > 30 k.p.h.
- lifting axle is lowered after ignition OFF
- lifting axle is raised after vehicle was stopped once and subsequently moved at >20 k.p.h. up to 2.4 bar
- raising the level by 10 counts at driving level for improved tyre clearance when lifting axle is raised
- raising the level by 10 counts when traction help is active
- unloading level to buffer when switch has been activated (160 counts)
- raising/lowering from remote-control unit up to calibrated upper value and mechanical stop at bottom
- automatic driving level from 20 k.p.h.
- 2 driving levels selectable from remote-control unit
- DL II > DL I
- remote-control unit cleared up to 15 k.p.h.
- 2 freely programmable memory levels via remote-control unit
- left/right control of vehicle possible from remote-control unit (raise/lower) (left = front, right = rear)
- 2 seconds control delay while stationary and 60 seconds when in motion
- power supply from WABCO EBS

bellows pressure laden 4.0 bar

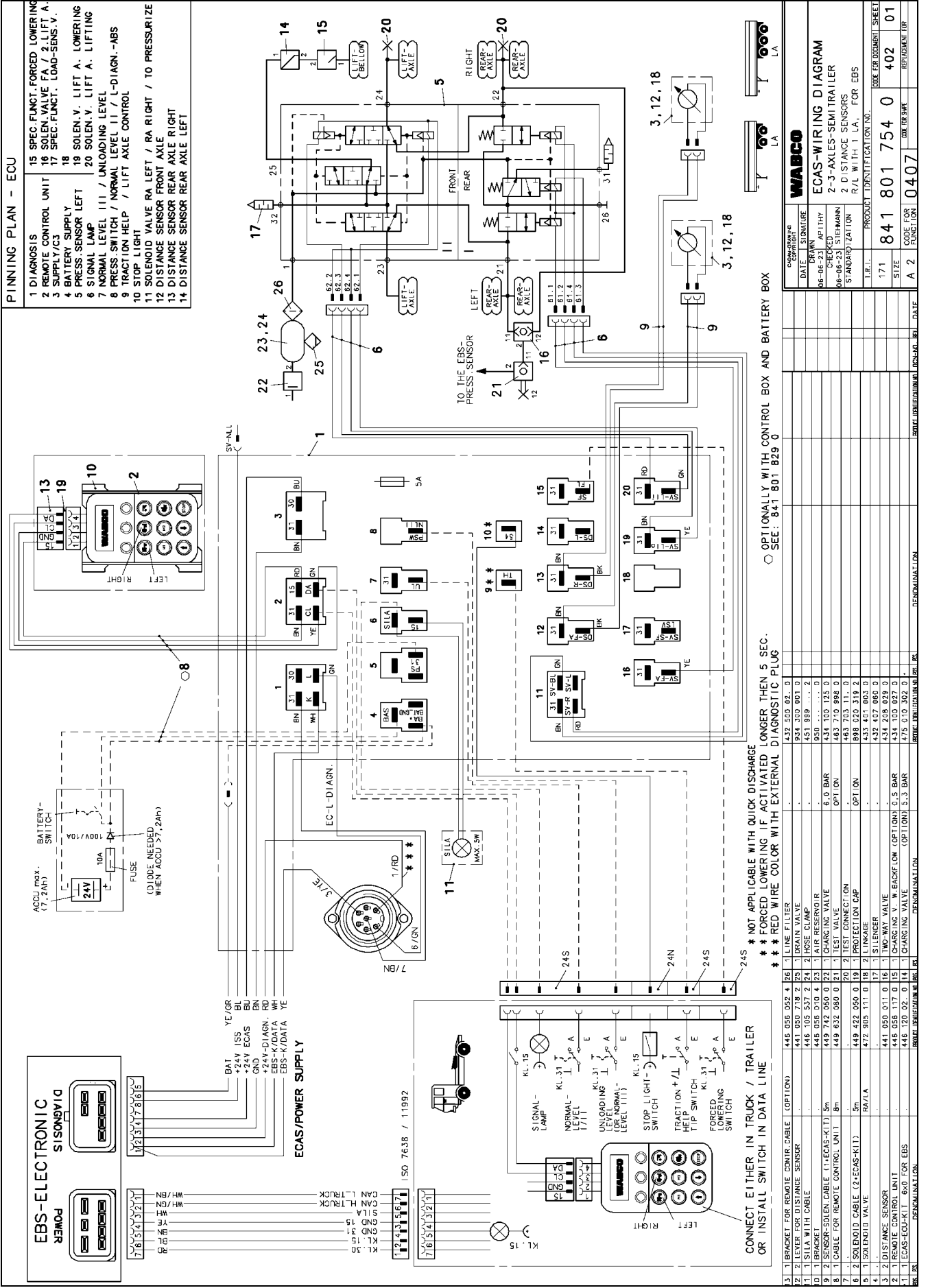

List of Parameters Trailer ECAS

ECU Variant: 446 055 066 0

Circuit Diagram No.: 841 801 755 0

Parameter Record No.: 8418017550

Par.		Value	Unit
P 0	=	18	
P 1	=	8	
P 2	=	13	
P 3	=	252	
P 4	=	5	
P 5	=	0	counts
P 6	=	15	counts
P 7	=	0	counts
P 8	=	115	counts
P 9	=	0	counts
P10	=	5	counts
P11	=	6	counts
P12	=	255	counts
P13	=	255	counts
P14	=	20	counts
P15	=	15	k.p.h.
P16	=	8	250ms
P17	=	12	25ms
P18	=	80	250ms
P19	=	0	1/3counts

Par.		Value	Unit
P20	=	10	1/3counts
P21	=	0	1/3counts
P22	=	20	1/3counts
P23	=	0	counts
P24	=	115	counts
P25	=	255	k.p.h.
P26	=	0	k.p.h.
P27	=	240	250ms
P28	=	64	1/16bar
P29	=	38	1/16bar
P30	=	96	1/16bar
P31	=	20	k.p.h.
P32	=	18	5s
P33	=	255	5s
P34	=	0	5s
P35	=	20	k.p.h.
P36	=	30	k.p.h.
P37	=	83	1/16bar
P38	=	4	1/16bar
P39	=	10	counts

Par.		Value	Unit
P40	=	120	10s
P41	=	20	k.p.h.
P42	=	0	1/16bar
P43	=	0	1/16bar
P44	=	0	counts
P45	=	0	1/16bar
P46	=	0	1/16bar
P47	=	0	10s
P48	=	48	15min
P49	=	10	counts
P50	=	100	300ms
P51	=	20	k.p.h.
P52	=	10	counts

System Description:

- semitrailer with two height sensors
- automatic lifting axle control and EC traction help
- lowering of lifting axle at a pressure of 4 bar in the supporting bellows
- raising the lifting axle up to a pressure of 2.4 bar in the supporting bellows
- lowering to the buffers due to 50% excess weight at a pressure of 6 bar in the supporting bellows
- traction help pressure of 5.2 bar in the supporting bellows
- starting traction help via remote-control unit or rocking switch
- ending traction help by pushing Stop button or holding rocking switch down for more than 5 sec. or Vlimit > 30 k.p.h.
- lifting axle is lowered after ignition OFF
- lifting axle is raised after vehicle was stopped once and subsequently moved at >20 k.p.h. up to 2.4 bar
- raising the level by 10 counts at driving level for improved tyre clearance when lifting axle is raised
- raising the level by 10 counts when traction help is active
- unloading level to buffer when switch has been activated (160 counts)
- raising/lowering from remote-control unit up to calibrated upper value and mechanical stop at bottom
- automatic driving level from 20 k.p.h.
- 2 driving levels selectable from remote-control unit
- DL II > DL I
- remote-control unit cleared up to 15 k.p.h.
- 2 freely programmable memory levels via remote-control unit
- 2 seconds control delay while stationary and 60 seconds when in motion
- power supply from WABCO EBS
- bellows pressure laden 4.0 bar**

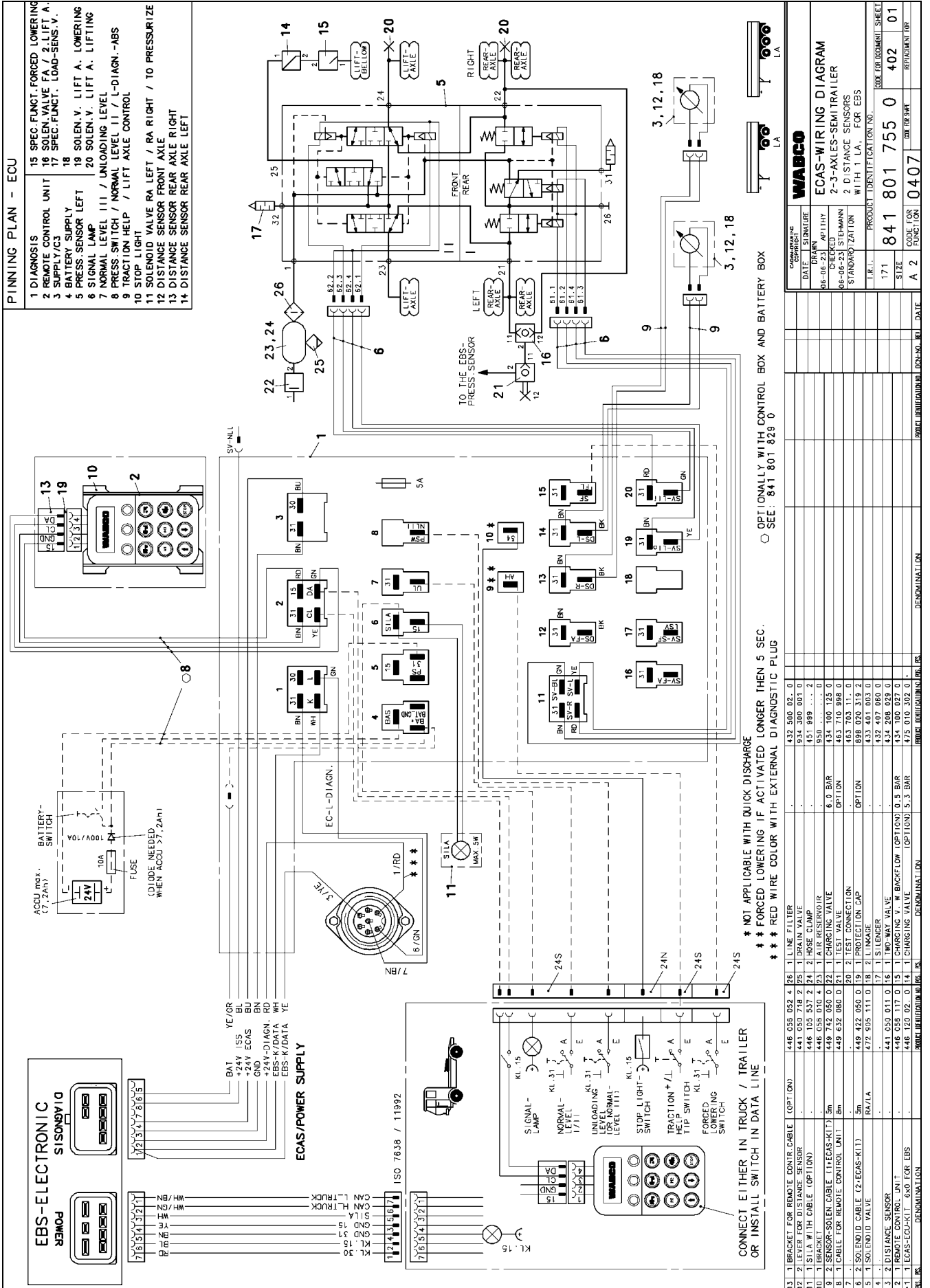

List of Parameters Trailer ECAS

ECU Variant: 446 055 066 0

Circuit Diagram No.: 841 801 756 0

Parameter Record No.: 8418017560

Par.		Value	Unit
P 0	=	18	
P 1	=	24	
P 2	=	77	
P 3	=	92	
P 4	=	5	
P 5	=	0	counts
P 6	=	160	counts
P 7	=	0	counts
P 8	=	115	counts
P 9	=	0	counts
P10	=	5	counts
P11	=	255	counts
P12	=	255	counts
P13	=	255	counts
P14	=	20	counts
P15	=	15	k.p.h.
P16	=	8	250ms
P17	=	12	25ms
P18	=	80	250ms
P19	=	0	1/3counts

Par.		Value	Unit
P20	=	10	1/3counts
P21	=	0	1/3counts
P22	=	20	1/3counts
P23	=	0	counts
P24	=	15	counts
P25	=	255	k.p.h.
P26	=	0	k.p.h.
P27	=	240	250ms
P28	=	64	1/16bar
P29	=	38	1/16bar
P30	=	96	1/16bar
P31	=	20	k.p.h.
P32	=	18	5s
P33	=	255	5s
P34	=	0	5s
P35	=	20	k.p.h.
P36	=	30	k.p.h.
P37	=	83	1/16bar
P38	=	4	1/16bar
P39	=	10	counts

Par.		Value	Unit
P40	=	120	10s
P41	=	20	k.p.h.
P42	=	0	1/16bar
P43	=	0	1/16bar
P44	=	0	counts
P45	=	17	1/16bar
P46	=	25	1/16bar
P47	=	30	10s
P48	=	48	15min
P49	=	10	counts
P50	=	100	300ms
P51	=	20	k.p.h.
P52	=	10	counts

System Description:

semitrailer with one height sensor
automatic lifting axle control for two separate lifting axles and EC traction help on Axle 1
lowering of lifting axle(s) at a pressure of 4 bar in the supporting bellows
raising the first lifting axle at a pressure of 2.4 bar in the supporting bellows
raising the second lifting axle at a pressure of 1.6 bar in the supporting bellows
simultaneously raising both lifting axle up to a pressure of 1.1 bar in the supporting bellows
lowering to the buffers due to 50% excess weight at a pressure of 6 bar in the supporting bellows
traction help pressure of 5.2 bar in the supporting bellows
starting traction help via remote-control unit or rocking switch
ending traction help by pushing Stop button or holding rocking switch down for more than 5 sec. or Vlimit > 30 k.p.h.
lifting axle is lowered after ignition OFF
lifting axle(s) is (are) raised after vehicle was stopped once and subsequently moved at >20 k.p.h. up to 2.4 bar
raising the level by 10 counts at driving level for improved tyre clearance when lifting axle is raised
raising the level by 10 counts when traction help is active
unloading level to buffer when switch has been activated (160 counts)
raising/lowering from remote-control unit up to calibrated upper value and mechanical stop at bottom
automatic driving level from 20 k.p.h.
2 driving levels selectable from remote-control unit
DL II > DL I
remote-control unit cleared up to 15 k.p.h.
2 freely programmable memory levels via remote-control unit
2 seconds control delay while stationary and 60 seconds when in motion
power supply from WABCO EBS

bellows pressure laden 4.0 bar

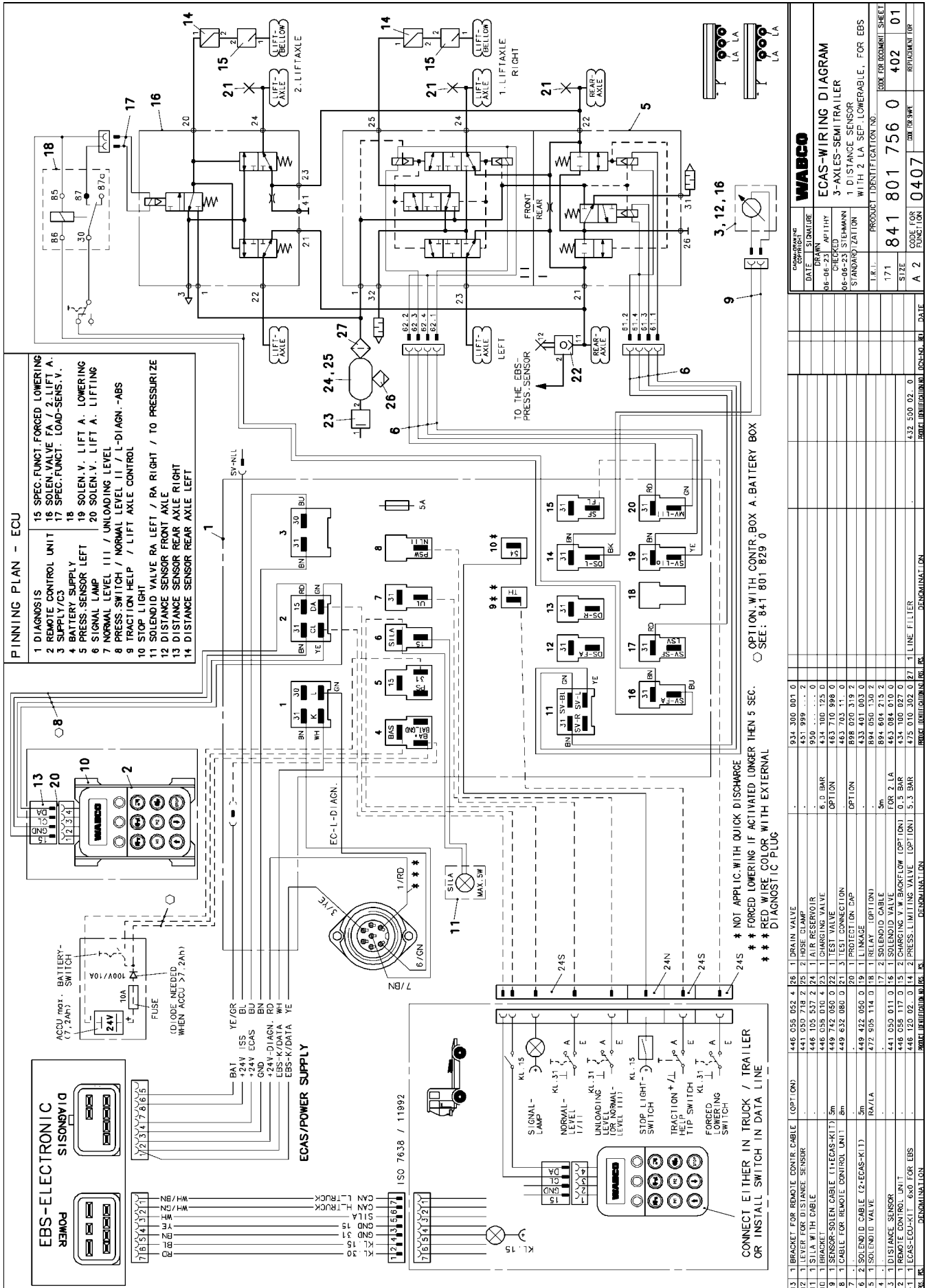

NO.	DESCRIPTION	QTY	REMARKS
31	BRACKET FOR REMOTE CONTR. CABLE (OPTION)	448 055 052 4	151 1 DRAIN VALVE
32	LEVER FOR DISTANCE SENSOR	443 030 718 2	25 2 HOSE CLAMP
33	SILVA WITH CABLE	446 050 537 2	24 1 AIR RESERVOIR
34	BRACKET	446 050 010 4	23 1 CHARGING VALVE
35	SENSOR-SOLEN CABLE (1-ECAS-KIT)	449 742 050 0	22 1 TEST VALVE
36	CABLE FOR REMOTE CONTROL UNIT	449 632 080 0	21 3 TEST CONNECTION
37	SOLENOID VALVE (2-ECAS-KIT)	449 422 050 0	19 1 PROTECT. ON CAP
38	SOLENOID VALVE	447 905 114 0	18 1 RELAY (OPTION)
39	DISTANCE SENSOR	441 050 011 0	16 1 SOLENOID VALVE
40	REMOTE CONTROL UNIT	448 058 117 0	15 2 CHARGING V.W. BACKFLOW (OPTION)
41	ECAS-ECU-KIT 6X0 FOR EBS	448 120 022 0	14 2 PRESS. LIFTING VALVE (OPTION)
42	DENOMINATION	448 100 027 0	13 1 LINE FILTER

NO.	DESCRIPTION	QTY	REMARKS
831	300 001 0	1	
832	999 000 0	1	
833	999 000 0	1	
834	100 125 0	1	
835	100 998 0	1	
836	703 11 0	1	
837	090 319 2	1	
838	401 003 0	1	
839	050 130 2	1	
840	084 011 0	1	
841	102 027 0	1	
842	302 027 0	1	
843	302 027 0	1	

NO.	DESCRIPTION	QTY	REMARKS
931	300 001 0	1	
932	999 000 0	1	
933	999 000 0	1	
934	100 125 0	1	
935	100 998 0	1	
936	703 11 0	1	
937	090 319 2	1	
938	401 003 0	1	
939	050 130 2	1	
940	084 011 0	1	
941	102 027 0	1	
942	302 027 0	1	
943	302 027 0	1	

NO.	DESCRIPTION	QTY	REMARKS
171	841 801 756 0	1	171
172	841 801 756 0	1	171
173	841 801 756 0	1	171
174	841 801 756 0	1	171
175	841 801 756 0	1	171
176	841 801 756 0	1	171
177	841 801 756 0	1	171
178	841 801 756 0	1	171
179	841 801 756 0	1	171
180	841 801 756 0	1	171
181	841 801 756 0	1	171
182	841 801 756 0	1	171
183	841 801 756 0	1	171
184	841 801 756 0	1	171
185	841 801 756 0	1	171
186	841 801 756 0	1	171
187	841 801 756 0	1	171
188	841 801 756 0	1	171
189	841 801 756 0	1	171
190	841 801 756 0	1	171
191	841 801 756 0	1	171
192	841 801 756 0	1	171
193	841 801 756 0	1	171
194	841 801 756 0	1	171
195	841 801 756 0	1	171
196	841 801 756 0	1	171
197	841 801 756 0	1	171
198	841 801 756 0	1	171
199	841 801 756 0	1	171
200	841 801 756 0	1	171

List of Parameters Trailer ECAS

ECU Variant: 446 055 066 0

Circuit Diagram No.: 841 801 757 0

Parameter Record No.: 8418017570

Par.		Value	Unit
P 0	=	18	
P 1	=	24	
P 2	=	13	
P 3	=	92	
P 4	=	5	
P 5	=	0	counts
P 6	=	160	counts
P 7	=	0	counts
P 8	=	115	counts
P 9	=	0	counts
P10	=	5	counts
P11	=	255	counts
P12	=	255	counts
P13	=	255	counts
P14	=	20	counts
P15	=	15	k.p.h.
P16	=	8	250ms
P17	=	12	25ms
P18	=	80	250ms
P19	=	0	1/3counts

Par.		Value	Unit
P20	=	10	1/3counts
P21	=	0	1/3counts
P22	=	20	1/3counts
P23	=	0	counts
P24	=	15	counts
P25	=	255	k.p.h.
P26	=	0	k.p.h.
P27	=	240	250ms
P28	=	8	1/16bar
P29	=	4	1/16bar
P30	=	96	1/16bar
P31	=	20	k.p.h.
P32	=	18	5s
P33	=	255	5s
P34	=	0	5s
P35	=	20	k.p.h.
P36	=	30	k.p.h.
P37	=	83	1/16bar
P38	=	4	1/16bar
P39	=	10	counts

Par.		Value	Unit
P40	=	120	10s
P41	=	20	k.p.h.h
P42	=	0	1/16bar
P43	=	0	1/16bar
P44	=	0	counts
P45	=	0	1/16bar
P46	=	0	1/16bar
P47	=	30	10s
P48	=	48	15min
P49	=	10	counts
P50	=	100	300ms
P51	=	20	k.p.h.
P52	=	10	counts

System Description:

- semitrailer with one height sensor
- no lifting axle control / no traction help
- trailing axle as manoeuvring aid on last axle
- trailing axle pressure of 5.2 bar supporting bellows pressure
- starting manoeuvring aid via remote-control unit or rocking switch
- ending manoeuvring aid by pushing Stop button or holding rocking switch down for more than 5 sec. or Vlimit > 30 k.p
- raising the level by 10 counts when manoeuvring aid is active
- unloading level to buffer when switch has been activated (160 counts)
- raising/lowering from remote-control unit up to calibrated upper value and mechanical stop at bottom
- automatic driving level from 20 k.p.h.
- 2 driving levels selectable from remote-control unit
- DL II > DL I
- remote-control unit cleared up to 15 k.p.h.
- 2 freely programmable memory levels via remote-control unit
- 2 seconds control delay while stationary and 60 seconds when in motion
- power supply from WABCO EBS

bellows pressure laden 4.0 bar

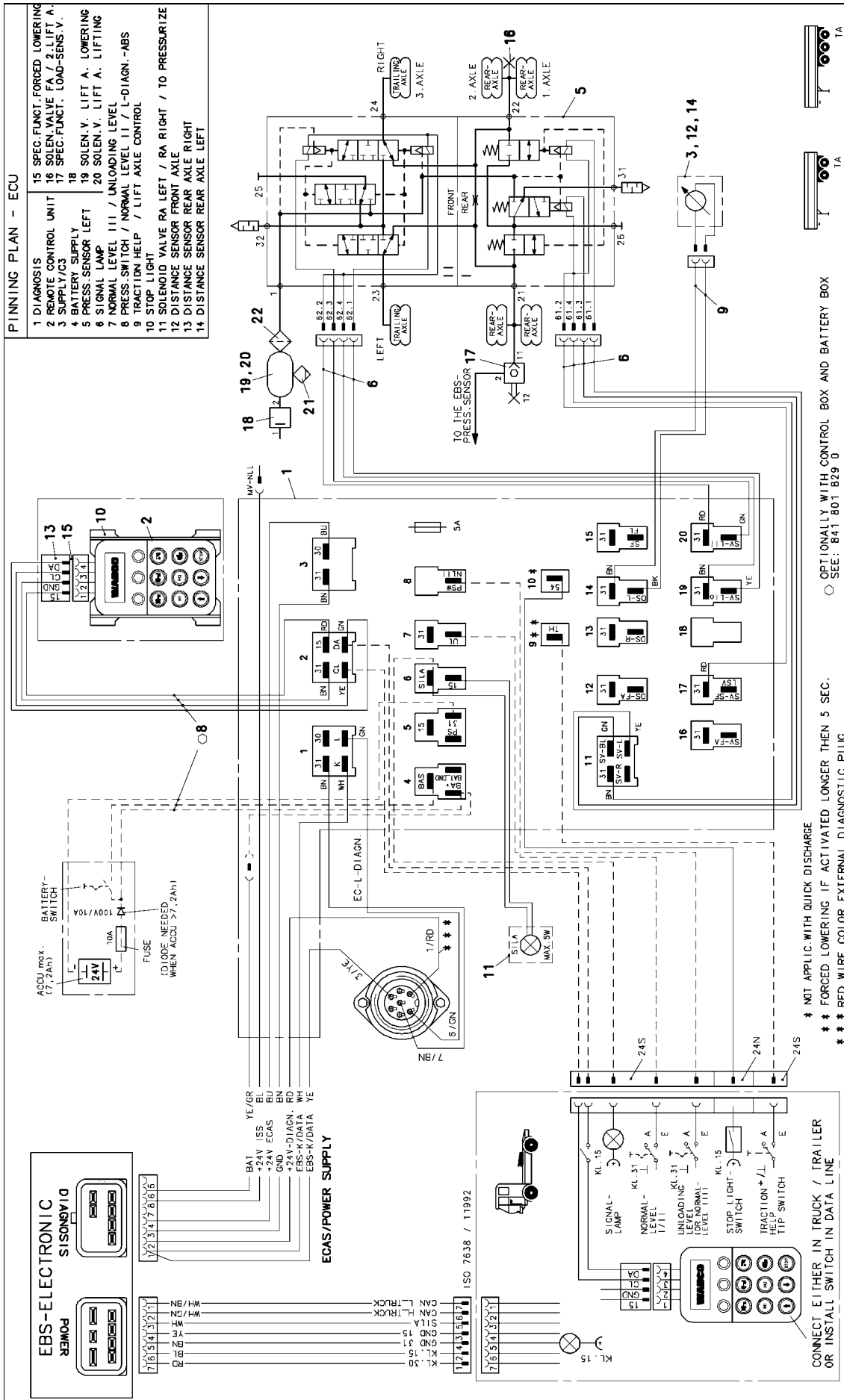

QTY	REF. NO.	DESCRIPTION	UNIT	REF. SHEET
31	BRACKET FOR REMOTE CONTR. CABLE	(OPT. ON)		
446	030 052 4			
441	030 718 2			
446	105 537 2			
446	055 010 4			
449	742 050 0	22. LINE FILTER		435 500 02. 0
449	632 060 0	21. DRAIN VALVE		934 300 001 0
449	432 080 0	19. AIR RESERVOIR		930 939 ... 0
449	432 050 0	18. CHARGING VALVE		6. D BAR
472	955 114 0	17. TEST VALVE		434 100 125 0
441	030 011 0	16. TEST CONNECTION		463 710 998 0
446	055 117 0	15. PROTECTION CAP		463 703 11. 0
446	120 02. 0	14. LINKAGE		888 020 319 2
446	055 010 4			433 451 003 0. 1

QTY	REF. NO.	DESCRIPTION	UNIT	REF. SHEET
31	BRACKET FOR REMOTE CONTR. CABLE	(OPT. ON)		
441	030 718 2			
446	105 537 2			
446	055 010 4			
449	742 050 0	22. LINE FILTER		435 500 02. 0
449	632 060 0	21. DRAIN VALVE		934 300 001 0
449	432 080 0	19. AIR RESERVOIR		930 939 ... 0
449	432 050 0	18. CHARGING VALVE		6. D BAR
472	955 114 0	17. TEST VALVE		434 100 125 0
441	030 011 0	16. TEST CONNECTION		463 710 998 0
446	055 117 0	15. PROTECTION CAP		463 703 11. 0
446	120 02. 0	14. LINKAGE		888 020 319 2
446	055 010 4			433 451 003 0. 1

CONNECT EITHER IN TRUCK / TRAILER OR INSTALL SWITCH IN DATA LINE

* NOT APPLIC. WITH QUICK DISCHARGE
 ** FORCED LOWERING IF ACTIVATED LONGER THEN 5 SEC.
 *** RED WIRE COLOR EXTERNAL DIAGNOSTIC PLUG

OPTIONALLY WITH CONTROL BOX AND BATTERY BOX
 SEE: 841 801 829 0

WABCO	
DATE	06-06-23
DRAWN	AP1THY
CHECKED	
06-06-23	STEIMANN
STANDARD ZATION WITH 1 TRAILING AXLE CONTROL (MOVING A/D)	
L.R.L.	PRODUCT IDENTIFICATION NO.
17.1	841 801 757 0
SIZE	402
CODE FOR FUNCTION	01

List of Parameters Trailer ECAS

ECU Variant: 446 055 066 0

Circuit Diagram No.: 841 801 758 0

Parameter Record No.: 8418017580

Par.	Value	Unit
P 0	= 18	
P 1	= 14	
P 2	= 13	
P 3	= 252	
P 4	= 0	
P 5	= 15	counts
P 6	= 15	counts
P 7	= 115	counts
P 8	= 115	counts
P 9	= 5	counts
P10	= 5	counts
P11	= 6	counts
P12	= 255	counts
P13	= 15	counts
P14	= 20	counts
P15	= 15	k.p.h.
P16	= 8	250ms
P17	= 12	25ms
P18	= 80	250ms
P19	= 10	1/3counts

Par.	Value	Unit
P20	= 10	1/3counts
P21	= 20	1/3counts
P22	= 20	1/3counts
P23	= 115	counts
P24	= 115	counts
P25	= 255	k.p.h.
P26	= 0	k.p.h.
P27	= 240	250ms
P28	= 0	1/16bar
P29	= 0	1/16bar
P30	= 255	1/16bar
P31	= 0	k.p.h.
P32	= 0	5s
P33	= 0	5s
P34	= 0	5s
P35	= 0	k.p.h.
P36	= 0	k.p.h.
P37	= 0	1/16bar
P38	= 0	1/16bar
P39	= 0	counts

Par.	Value	Unit
P40	= 120	10s
P41	= 20	k.p.h.
P42	= 0	1/16bar
P43	= 0	1/16bar
P44	= 0	counts
P45	= 0	1/16bar
P46	= 0	1/16bar
P47	= 0	10s
P48	= 48	15min
P49	= 10	counts
P50	= 100	300ms
P51	= 0	k.p.h.
P52	= 0	counts

System Description:

drawbar trailer with two height sensors
 no lifting axle control / no traction help
 raising/lowering from remote-control unit up to calibrated upper value and mechanical stop at bottom
 automatic driving level from 20 k.p.h.
 3 driving levels selectable from remote-control unit
 DL III > DL I > DL II
 remote-control unit cleared up to 15 k.p.h.
 2 freely programmable memory levels via remote-control unit
 2 seconds control delay while stationary and 60 seconds when in motion
 power supply from WABCO EBS

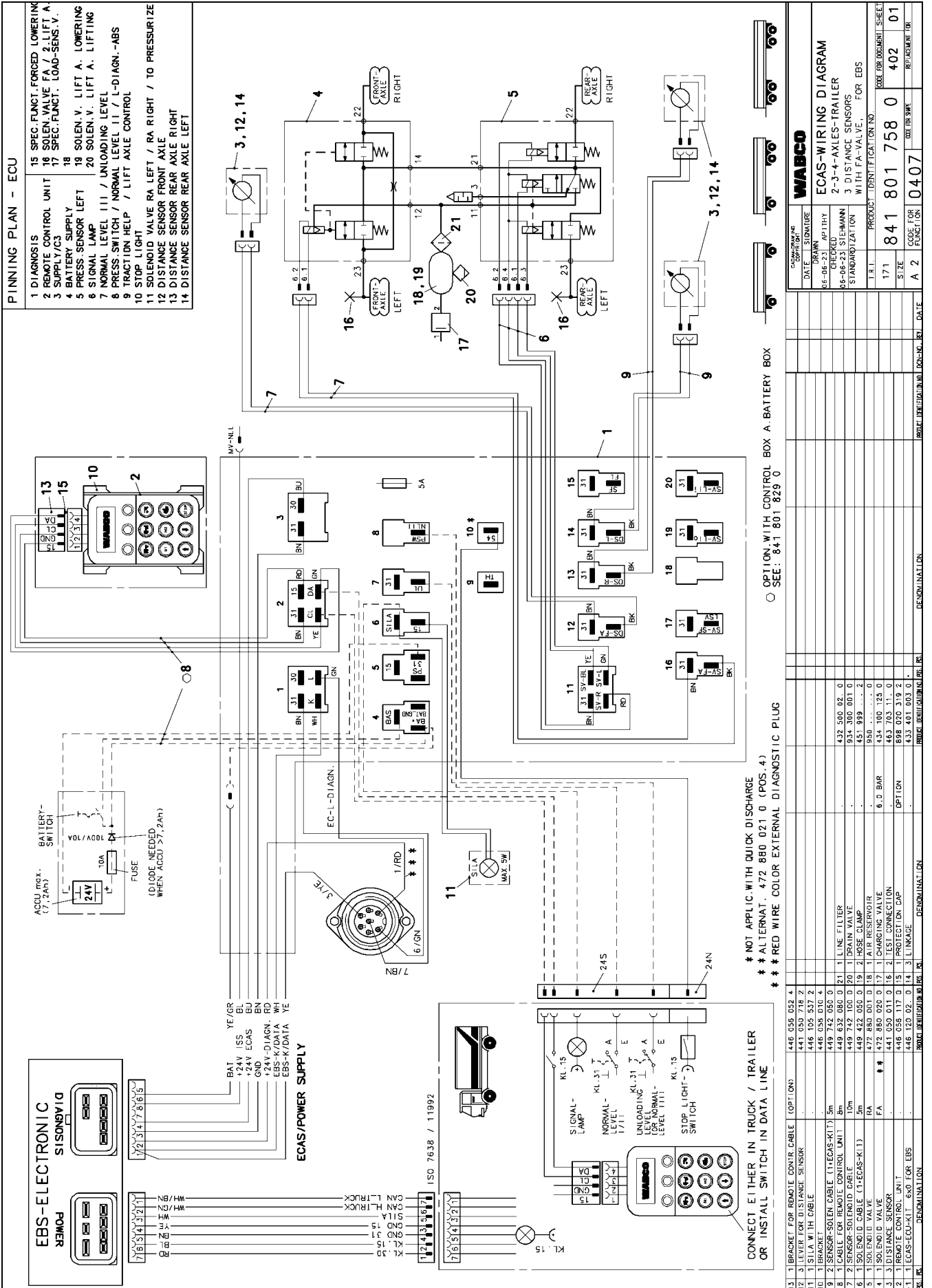

List of Parameters Trailer ECAS

ECU Variant: 446 055 066 0

Circuit Diagram No.: 841 801 759 0

Parameter Record No.: 8418017590

Par.		Value	Unit
P 0	=	18	
P 1	=	10	
P 2	=	13	
P 3	=	252	
P 4	=	5	
P 5	=	15	counts
P 6	=	15	counts
P 7	=	115	counts
P 8	=	115	counts
P 9	=	5	counts
P10	=	5	counts
P11	=	6	counts
P12	=	255	counts
P13	=	15	counts
P14	=	20	counts
P15	=	15	k.p.h.
P16	=	8	250ms
P17	=	12	25ms
P18	=	80	250ms
P19	=	10	1/3counts

Par.		Value	Unit
P20	=	10	1/3counts
P21	=	20	1/3counts
P22	=	20	1/3counts
P23	=	115	counts
P24	=	115	counts
P25	=	255	k.p.h.
P26	=	0	k.p.h.
P27	=	240	250ms
P28	=	64	1/16bar
P29	=	38	1/16bar
P30	=	96	1/16bar
P31	=	20	k.p.h.
P32	=	18	5s
P33	=	255	5s
P34	=	0	5s
P35	=	20	k.p.h.
P36	=	30	k.p.h.
P37	=	83	1/16bar
P38	=	4	1/16bar
P39	=	10	counts

Par.		Value	Unit
P40	=	120	10s
P41	=	20	k.p.h.
P42	=	0	1/16bar
P43	=	0	1/16bar
P44	=	0	counts
P45	=	0	1/16bar
P46	=	0	1/16bar
P47	=	0	10s
P48	=	48	15min
P49	=	10	counts
P50	=	100	300ms
P51	=	20	k.p.h.
P52	=	10	counts

System Description:

- semitrailer with three height sensors
- automatic lifting axle control and EC traction help
- lowering of lifting axle at a pressure of 4 bar in the supporting bellows
- raising the lifting axle up to a pressure of 2.4 bar in the supporting bellows
- lowering to the buffers due to 50% excess weight at a pressure of 6 bar in the supporting bellows
- traction help pressure of 5.2 bar in the supporting bellows
- starting traction help via remote-control unit or rocking switch
- ending traction help by pushing Stop button or holding rocking switch down for more than 5 sec. or Vlimit > 30 k.p.h.
- lifting axle is lowered after ignition OFF
- lifting axle is raised after vehicle was stopped once and subsequently moved at >20 k.p.h. up to 2.4 bar
- raising the level by 10 counts at driving level for improved tyre clearance when lifting axle is raised
- raising the level by 10 counts when traction help is active
- raising/lowering from remote-control unit up to calibrated upper value and mechanical stop at bottom
- automatic driving level from 20 k.p.h.
- 3 driving levels selectable from remote-control unit
- DL III > DL I > DL II
- remote-control unit cleared up to 15 k.p.h.
- 2 freely programmable memory levels via remote-control unit
- 2 seconds control delay while stationary and 60 seconds when in motion
- power supply from WABCO EBS

bellows pressure laden 4.0 bar

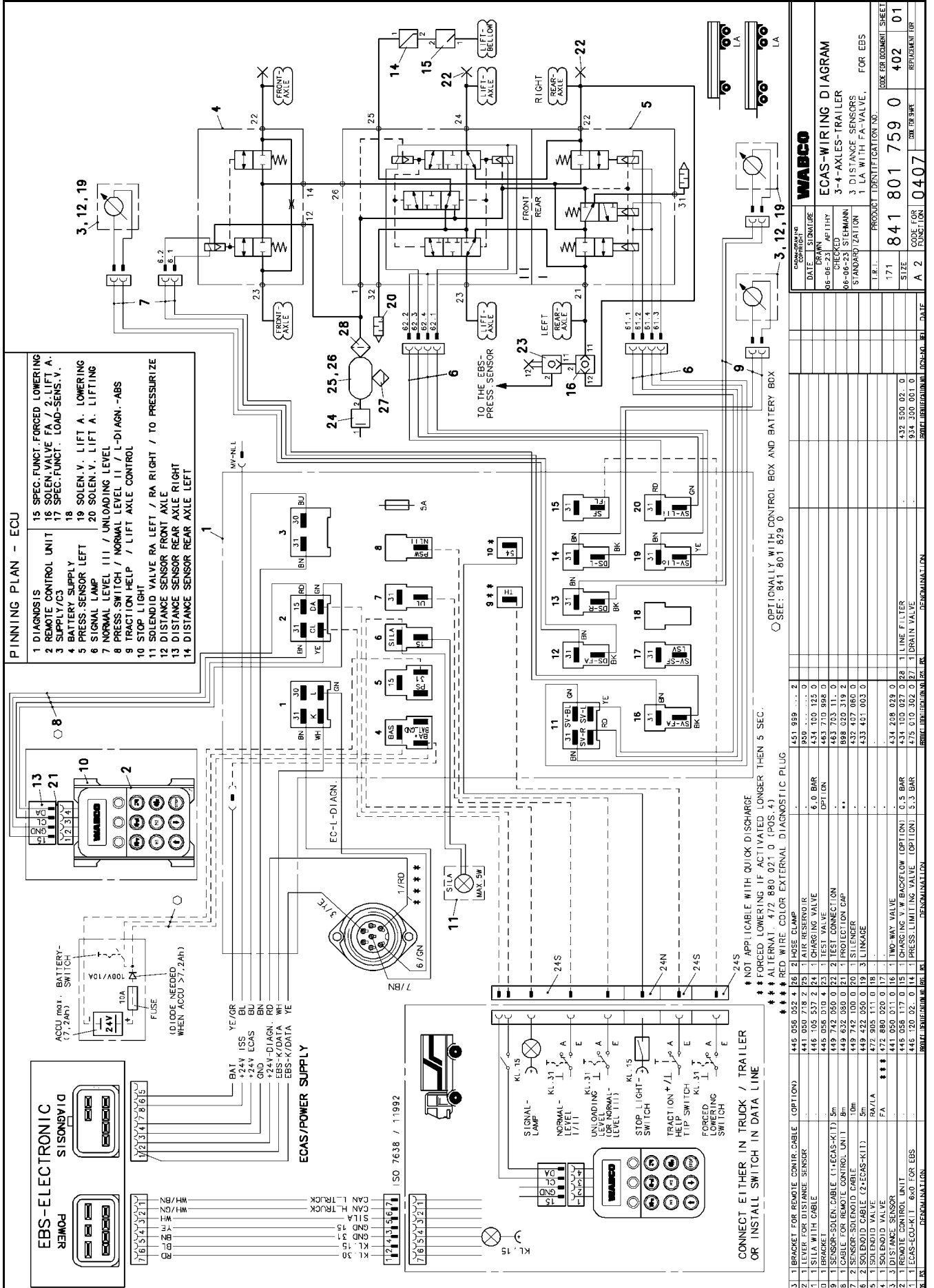

DATE		DRAWN		CHECKED		STANDARDIZATION		PRODUCT IDENTIFICATION NO.		CODE FOR DOCUMENT SHEET	
06-06-06		APL/THY		06-06-23		SIEHMANN		3 DISTANCE SENSORS 1 LA WITH FA-VALVE, FOR EBS		402 01	
A 2		171		841 801 759 0		0407		0407		01	
FUNCTION		SIZE		CODE FOR PART		REPLACEMENT FOR		DATE		REVISION	

List of Parameters Trailer ECAS

ECU Variant: 446 055 066 0

Circuit Diagram No.: 841 801 760 0

Circuit Diagram No.: 8418017600

Par.		Value	Unit
P 0	=	18	
P 1	=	24	
P 2	=	13	
P 3	=	92	
P 4	=	5	
P 5	=	0	counts
P 6	=	160	counts
P 7	=	0	counts
P 8	=	115	counts
P 9	=	0	counts
P10	=	5	counts
P11	=	255	counts
P12	=	255	counts
P13	=	255	counts
P14	=	20	counts
P15	=	15	k.p.h.
P16	=	8	250ms
P17	=	12	25ms
P18	=	80	250ms
P19	=	0	1/3counts

Par.		Value	Unit
P20	=	10	1/3counts
P21	=	0	1/3counts
P22	=	20	1/3counts
P23	=	0	counts
P24	=	15	counts
P25	=	255	k.p.h.
P26	=	0	k.p.h.
P27	=	240	250ms
P28	=	64	1/16bar
P29	=	38	1/16bar
P30	=	96	1/16bar
P31	=	20	k.p.h.
P32	=	18	5s
P33	=	255	5s
P34	=	0	5s
P35	=	20	k.p.h.
P36	=	30	k.p.h.
P37	=	83	1/16bar
P38	=	4	1/16bar
P39	=	10	counts

Par.		Value	Unit
P40	=	120	10s
P41	=	20	k.p.h.
P42	=	0	1/16bar
P43	=	0	1/16bar
P44	=	0	counts
P45	=	0	1/16bar
P46	=	0	1/16bar
P47	=	30	10s
P48	=	48	15min
P49	=	10	counts
P50	=	100	300ms
P51	=	20	k.p.h.
P52	=	10	counts

System Description:

semitrailer with one height sensor

automatic lifting axle control and EC traction help

lowering of lifting axle at a pressure of 4 bar in the supporting bellows

raising the lifting axle up to a pressure of 2.4 bar in the supporting bellows

lowering to the buffers due to 50% excess weight at a pressure of 6 bar in the supporting bellows

traction help pressure of 5.2 bar in the supporting bellows

starting traction help via remote-control unit or rocking switch

ending traction help by pushing Stop button or holding rocking switch down for more than 5 sec. or Vlimit > 30 k.p.h.

lifting axle is lowered after ignition OFF

lifting axle(s) is (are) raised after vehicle was stopped once and subsequently moved at >20 k.p.h. up to 2.4 bar

raising the level by 10 counts at driving level for improved tyre clearance when lifting axle is raised

raising the level by 10 counts when traction help is active

unloading level to buffer when switch has been activated (160 counts)

raising/lowering from remote-control unit up to calibrated upper value and mechanical stop at bottom

automatic driving level from 20 k.p.h.

2 driving levels selectable from remote-control unit

DL II > DL I

remote-control unit cleared up to 15 k.p.h.

2 freely programmable memory levels via remote-control unit

2 seconds control delay while stationary and 60 seconds when in motion

power supply from WABCO EBS

bellows pressure laden 4.0 bar

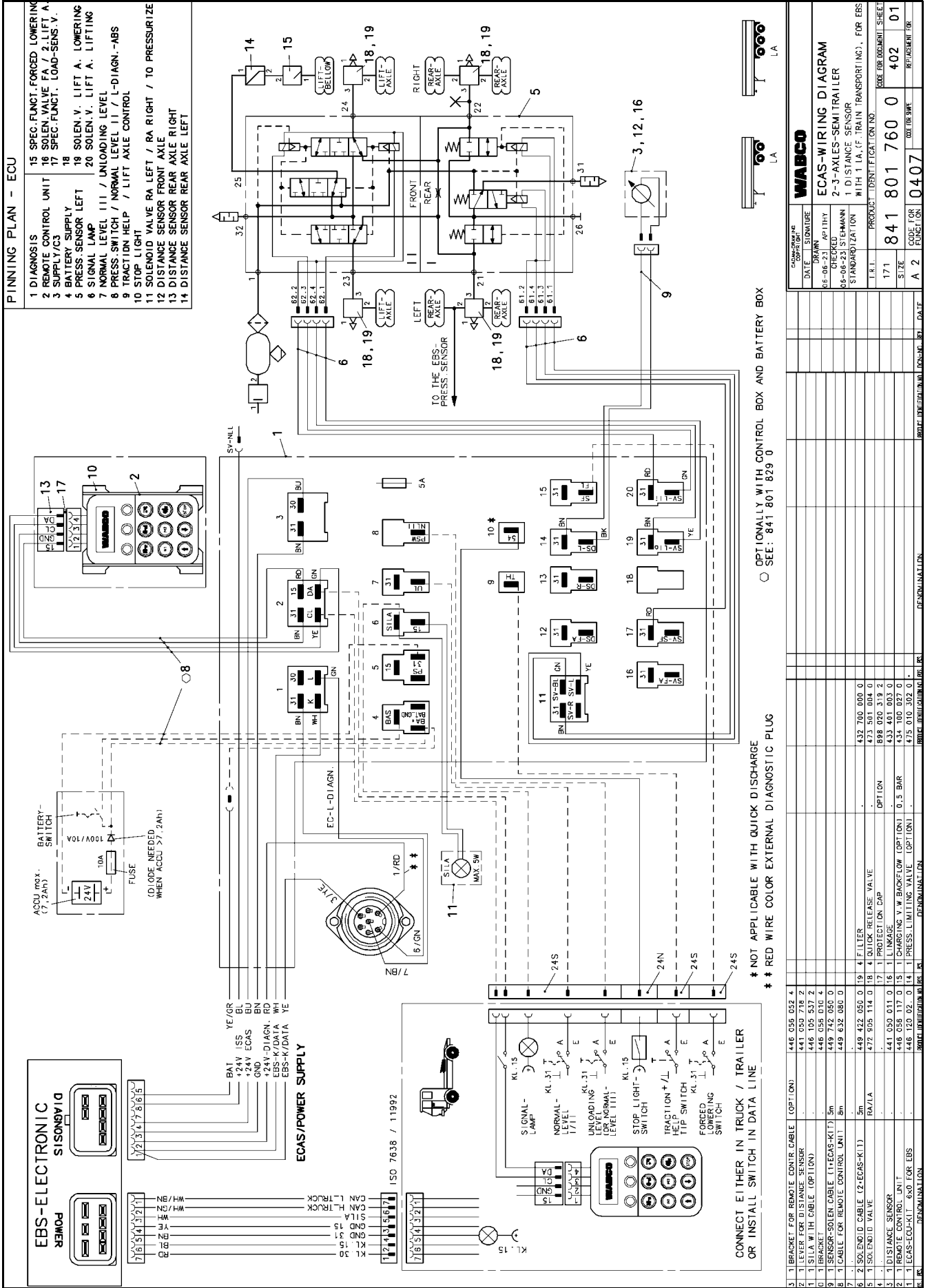

List of Parameters Trailer ECAS

ECU Variant: 446 055 066 0

Circuit Diagram No.: 841 801 761 0

Parameter Record No.: 8418017610

Par.	Value	Unit
P 0	18	
P 1	24	
P 2	13	
P 3	92	
P 4	5	
P 5	0	counts
P 6	160	counts
P 7	0	counts
P 8	115	counts
P 9	0	counts
P10	5	counts
P11	255	counts
P12	255	counts
P13	255	counts
P14	20	counts
P15	15	k.p.h.
P16	8	250ms
P17	12	25ms
P18	80	250ms
P19	0	1/3counts

Par.	Value	Unit
P20	10	1/3counts
P21	0	1/3counts
P22	20	1/3counts
P23	0	counts
P24	15	counts
P25	255	k.p.h.
P26	0	k.p.h.
P27	240	250ms
P28	8	1/16bar
P29	4	1/16bar
P30	96	1/16bar
P31	20	k.p.h.
P32	18	5s
P33	255	5s
P34	0	5s
P35	20	k.p.h.
P36	30	k.p.h.
P37	83	1/16bar
P38	4	1/16bar
P39	10	counts

Par.	Value	Unit
P40	120	10s
P41	20	k.p.h.
P42	0	1/16bar
P43	0	1/16bar
P44	0	counts
P45	0	1/16bar
P46	0	1/16bar
P47	30	10s
P48	48	15min
P49	10	counts
P50	100	300ms
P51	20	k.p.h.
P52	10	counts

System Description:

semitrailer with one height sensor
 no lifting axle control
 EC traction help on Axle 1
 lowering to the buffers due to 50% excess weight at a pressure of 6 bar in the supporting bellows
 traction help pressure of 5.2 bar in the supporting bellows
 starting traction help via remote-control unit or rocking switch
 ending traction help by pushing Stop button or holding rocking switch down for more than 5 sec. or Vlimit > 30 k.p.h.
 raising the level by 10 counts when traction help is active
 unloading level to buffer when switch has been activated (160 counts)
 raising/lowering from remote-control unit up to calibrated upper value and mechanical stop at bottom
 automatic driving level from 20 k.p.h.
 2 driving levels selectable from remote-control unit
 DL II > DL I
 remote-control unit cleared up to 15 k.p.h.
 2 freely programmable memory levels via remote-control unit
 2 seconds control delay while stationary and 60 seconds when in motion
 power supply from WABCO EBS

bellows pressure laden 4.0 bar

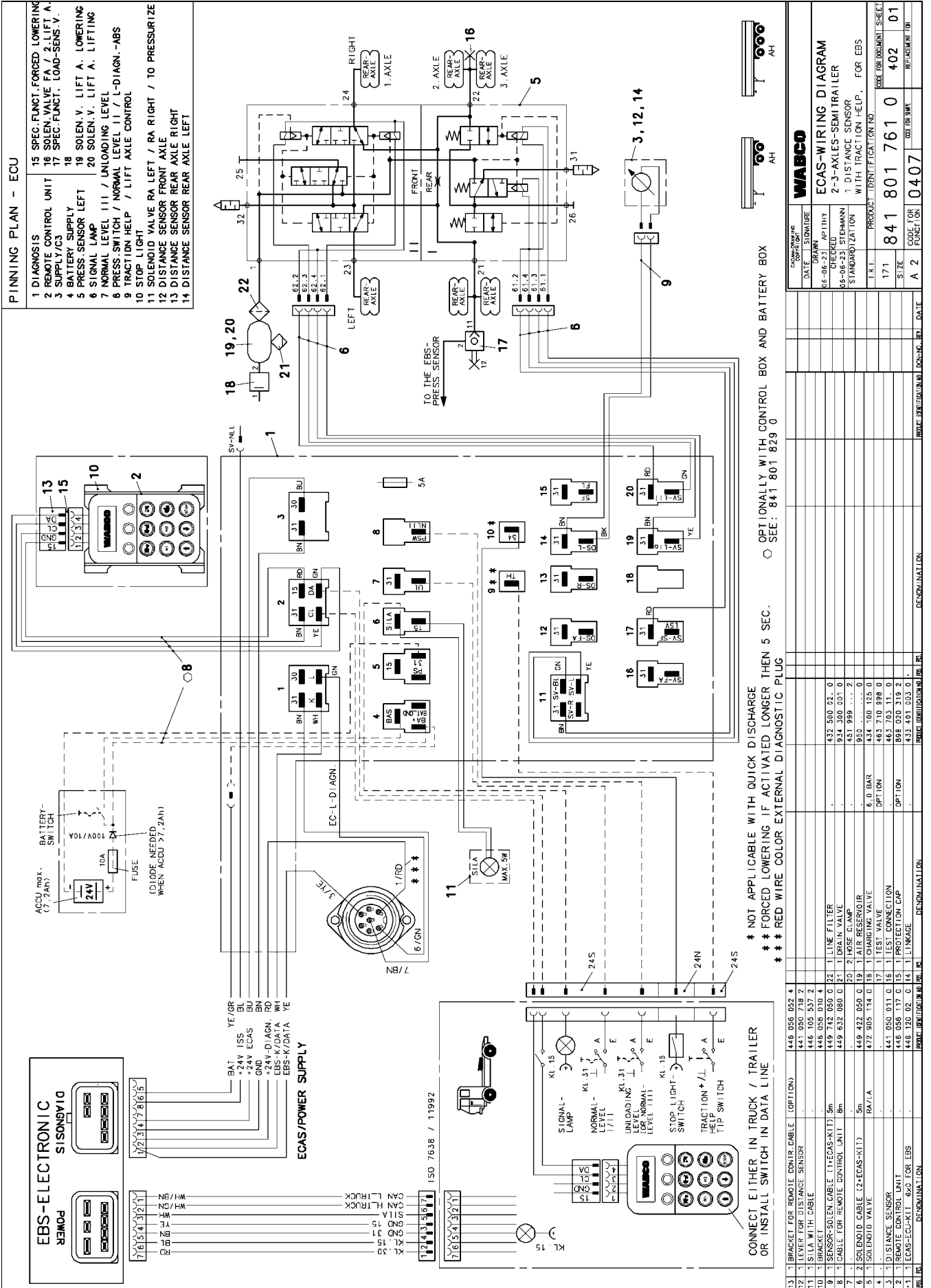

List of Parameters Trailer ECAS

ECU Variant: 446 055 066 0

Circuit Diagram No.: 841 801 762 0

Parameter Record No.: 8418017620

Par.		Value	Unit
P 0	=	18	
P 1	=	28	
P 2	=	9	
P 3	=	124	
P 4	=	0	
P 5	=	0	counts
P 6	=	15	counts
P 7	=	0	counts
P 8	=	115	counts
P 9	=	0	counts
P10	=	5	counts
P11	=	255	counts
P12	=	255	counts
P13	=	255	counts
P14	=	20	counts
P15	=	15	k.p.h.
P16	=	8	250ms
P17	=	12	25ms
P18	=	80	250ms
P19	=	0	1/3counts

Par.		Value	Unit
P20	=	10	1/3counts
P21	=	0	1/3counts
P22	=	20	1/3counts
P23	=	0	counts
P24	=	115	counts
P25	=	70	k.p.h.
P26	=	30	k.p.h.
P27	=	240	250ms
P28	=	0	1/16bar
P29	=	0	1/16bar
P30	=	255	1/16bar
P31	=	0	k.p.h.
P32	=	0	5s
P33	=	0	5s
P34	=	0	5s
P35	=	0	k.p.h.
P36	=	0	k.p.h.
P37	=	0	1/16bar
P38	=	0	1/16bar
P39	=	0	counts

Par.		Value	Unit
P40	=	120	10s
P41	=	20	k.p.h.
P42	=	16	1/16bar
P43	=	64	1/16bar
P44	=	15	counts
P45	=	0	1/16bar
P46	=	0	1/16bar
P47	=	0	10s
P48	=	48	15min
P49	=	10	counts
P50	=	100	300ms
P51	=	0	k.p.h.
P52	=	0	counts

System Description:

semitrailer with one height sensor
 no lifting axle control / traction help
 compensating for tyre deflection for more spring travel when laden
 raising/lowering from remote-control unit up to calibrated upper value and mechanical stop at bottom
 automatic driving level from 20 k.p.h.
 2 driving levels selectable from remote-control unit
 DL III > DL I > DL II
 automatically addressing driving level II at Vlimit > 70 k.p.h.
 returning to driving level 1 when speed falls below Vlimit < 30 k.p.h.
 remote-control unit cleared up to 15 k.p.h.
 2 freely programmable memory levels via remote-control unit
 2 seconds control delay while stationary and 60 seconds when in motion
 power supply from WABCO EBS

bellows pressure laden 4.0 bar

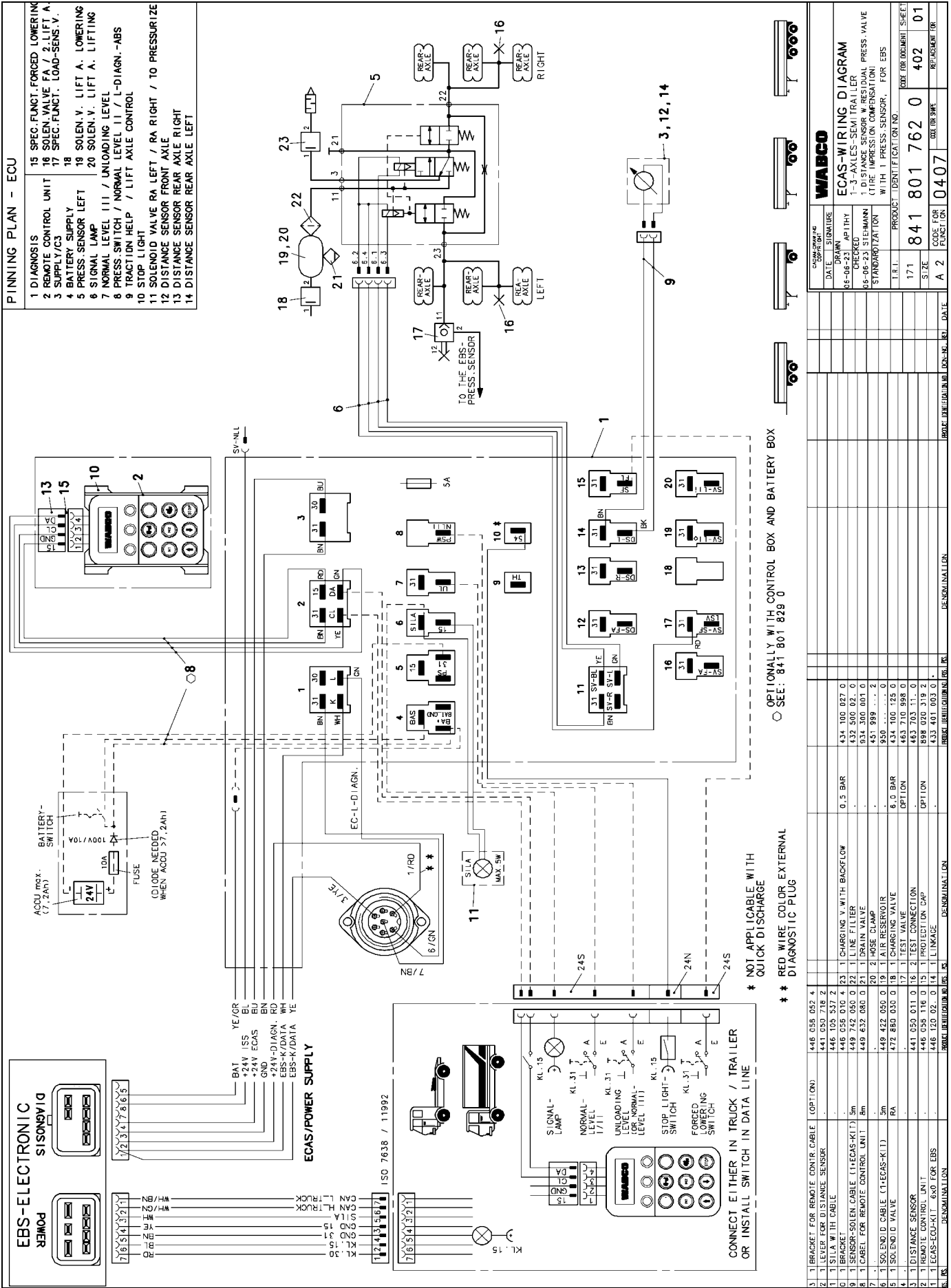

List of Parameters Trailer ECAS

ECU Variant: 446 055 066 0

Circuit Diagram No.: 841 801 763 0

Parameter Record No.: 8418017630

Par.	Value	Unit
P 0	= 18	
P 1	= 8	
P 2	= 77	
P 3	= 220	
P 4	= 5	
P 5	= 0	counts
P 6	= 160	counts
P 7	= 0	counts
P 8	= 115	counts
P 9	= 0	counts
P10	= 5	counts
P11	= 6	counts
P12	= 255	counts
P13	= 255	counts
P14	= 20	counts
P15	= 15	k.p.h.
P16	= 8	250ms
P17	= 12	25ms
P18	= 80	250ms
P19	= 0	1/3counts

Par.	Value	Unit
P20	= 10	1/3counts
P21	= 0	1/3counts
P22	= 20	1/3counts
P23	= 0	counts
P24	= 15	counts
P25	= 255	k.p.h.
P26	= 0	k.p.h.
P27	= 240	250ms
P28	= 64	1/16bar
P29	= 38	1/16bar
P30	= 96	1/16bar
P31	= 20	km/h
P32	= 18	5s
P33	= 255	5s
P34	= 0	5s
P35	= 20	k.p.h.
P36	= 30	k.p.h.
P37	= 83	1/16bar
P38	= 4	1/16bar
P39	= 10	counts

Par.	Value	Unit
P40	= 120	10s
P41	= 20	k.p.h.
P42	= 0	1/16bar
P43	= 0	1/16bar
P44	= 0	counts
P45	= 17	1/16bar
P46	= 25	1/16bar
P47	= 30	10s
P48	= 48	15min
P49	= 10	counts
P50	= 100	300ms
P51	= 20	k.p.h.
P52	= 10	counts

System Description:

semitrailer with two height sensors
 automatic lifting axle control for two separate lifting axles and EC traction help on Axle 1
 lowering of lifting axle(s) at a pressure of 4 bar in the supporting bellows
 raising the first lifting axle at a pressure of 2.4 bar in the supporting bellows
 raising the second lifting axle at a pressure of 1.6 bar in the supporting bellows
 simultaneously raising both lifting axle up to a pressure of 1.1 bar in the supporting bellows
 lowering to the buffers due to 50% excess weight at a pressure of 6 bar in the supporting bellows
 traction help pressure of 5.2 bar in the supporting bellows
 starting traction help via remote-control unit or rocking switch
 ending traction help by pushing Stop button or holding rocking switch down for more than 5 sec. or Vlimit > 30 k.p.h.
 lifting axle is lowered after ignition OFF
 lifting axle(s) is (are) raised after vehicle was stopped once and subsequently moved at >20 k.p.h. up to 2.4 bar
 raising the level by 10 counts at driving level for improved tyre clearance when lifting axle is raised
 raising the level by 10 counts when traction help is active
 unloading level to buffer when switch has been activated (160 counts)
 raising/lowering from remote-control unit up to calibrated upper value and mechanical stop at bottom
 automatic driving level from 20 k.p.h.
 2 driving levels selectable from remote-control unit
 DL II > DL I
 remote-control unit cleared up to 15 k.p.h.
 2 freely programmable memory levels via remote-control unit
 2 seconds control delay while stationary and 60 seconds when in motion
 power supply from WABCO EBS

bellows pressure laden 4.0 bar

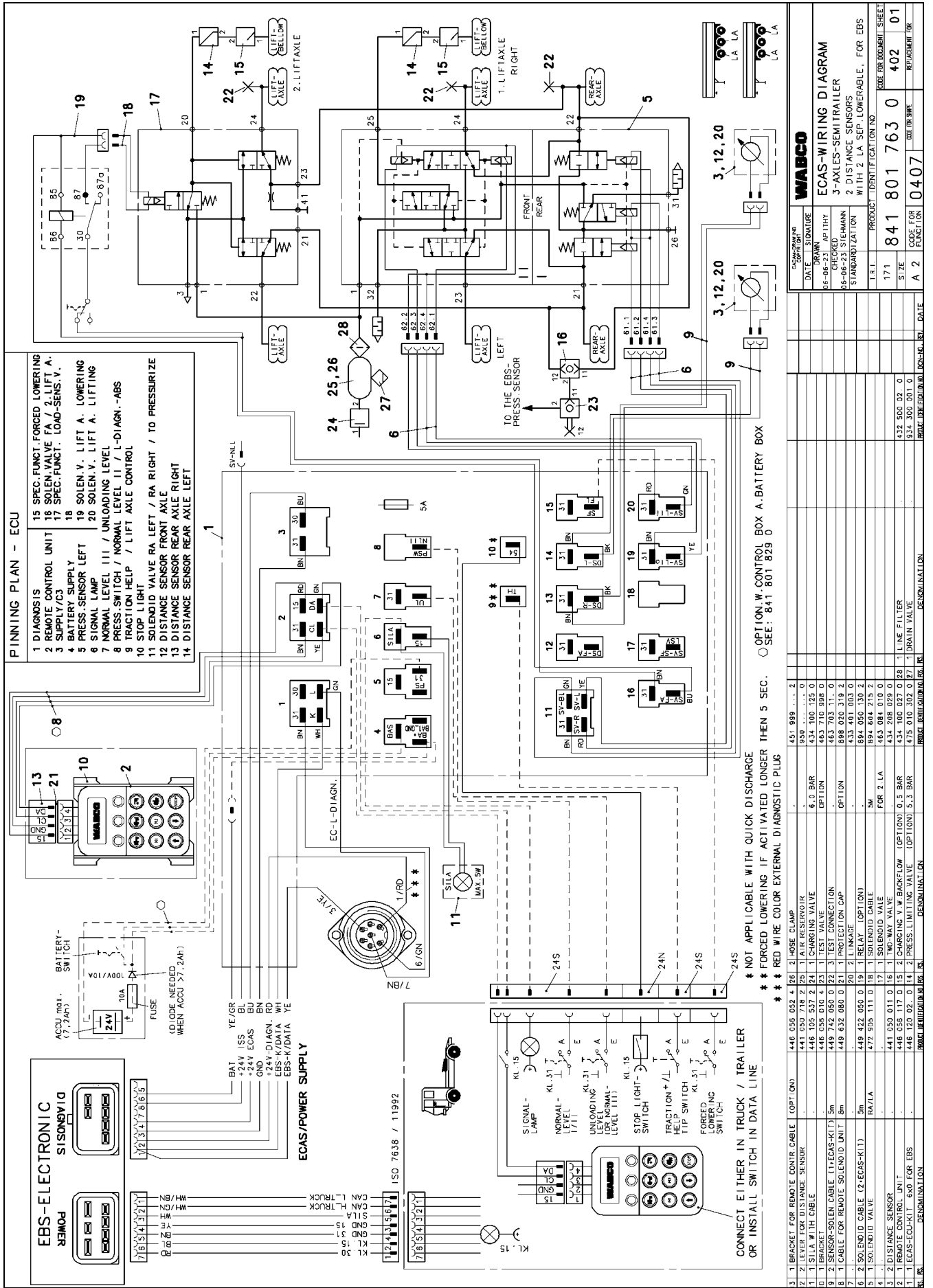

DATE	17.1	SIZE	402	REFINEMENT FOR	01
DRAWN BY	841 801 763 0	CODE FOR	0407	DATE	
CHECKED BY		FUNCTION			
STANDARDIZATION					
PRODUCT IDENTIFICATION					
WABCO					
ECAS-WIRING DIAGRAM					
3-AXLES-SEMI TRAILER					
2-DISTANCE SENSORS					
WITH 2 LA SEP. LOWERABLE, FOR EBS					

List of Parameters Trailer ECAS

ECU Variant: 446 055 066 0

Circuit Diagram No.: 841 801 764 0

Parameter Record No.: 8418017640

Par.		Value	Unit
P 0	=	18	
P 1	=	58	
P 2	=	13	
P 3	=	220	
P 4	=	5	
P 5	=	160	counts
P 6	=	160	counts
P 7	=	115	counts
P 8	=	115	counts
P 9	=	5	counts
P10	=	5	counts
P11	=	255	counts
P12	=	255	counts
P13	=	255	counts
P14	=	20	counts
P15	=	15	k.p.h
P16	=	8	250ms
P17	=	12	25ms
P18	=	80	250ms
P19	=	10	1/3counts

Par.		Value	Unit
P20	=	10	1/3counts
P21	=	20	1/3counts
P22	=	20	1/3counts
P23	=	15	counts
P24	=	15	counts
P25	=	255	k.p.h
P26	=	0	k.p.h
P27	=	240	250ms
P28	=	64	1/16bar
P29	=	17	1/16bar
P30	=	96	1/16bar
P31	=	20	k.p.h
P32	=	18	5s
P33	=	255	5s
P34	=	0	5s
P35	=	20	k.p.h
P36	=	30	k.p.h
P37	=	83	1/16bar
P38	=	4	1/16bar
P39	=	10	counts

Par.		Value	Unit
P40	=	120	10s
P41	=	20	k.p.h
P42	=	0	1/16bar
P43	=	0	1/16bar
P44	=	0	counts
P45	=	0	1/16bar
P46	=	0	1/16bar
P47	=	30	10s
P48	=	48	15min
P49	=	10	counts
P50	=	100	300ms
P51	=	20	k.p.h
P52	=	10	counts

System Description:

semitrailer with two height sensors
 automatic lifting axle control for two connected in parallel lifting axles and EC traction help
 lowering of lifting axle at a pressure of 4 bar in the supporting bellows
 raising the lifting axle up to a pressure of 1.1 bar in the supporting bellows
 lowering to the buffers due to 50% excess weight at a pressure of 6 bar in the supporting bellows
 traction help pressure of 5.2 bar in the supporting bellows
 starting traction help via remote-control unit or rocking switch
 ending traction help by pushing Stop button or holding rocking switch down for more than 5 sec. or Vlimit > 30 k.p.h.
 lifting axle is lowered after ignition OFF
 lifting axle is raised after vehicle was stopped once and subsequently moved at >20 k.p.h. up to 1.1 bar
 raising the level by 10 counts at driving level for improved tyre clearance when lifting axle is raised
 raising the level by 10 counts when traction help is active
 unloading level to buffer when switch has been activated (160 counts)
 raising/lowering from remote-control unit up to calibrated upper value and mechanical stop at bottom
 automatic driving level from 20 k.p.h.
 2 driving levels selectable from remote-control unit
 DL II > DL I
 remote-control unit cleared up to 15 k.p.h.
 left/right control of vehicle possible from remote-control unit (raise/lower) (left = front, right = rear)
 2 freely programmable memory levels via remote-control unit
 2 seconds control delay while stationary and 60 seconds when in motion
 power supply from WABCO EBS

bellows pressure laden 4.0 bar

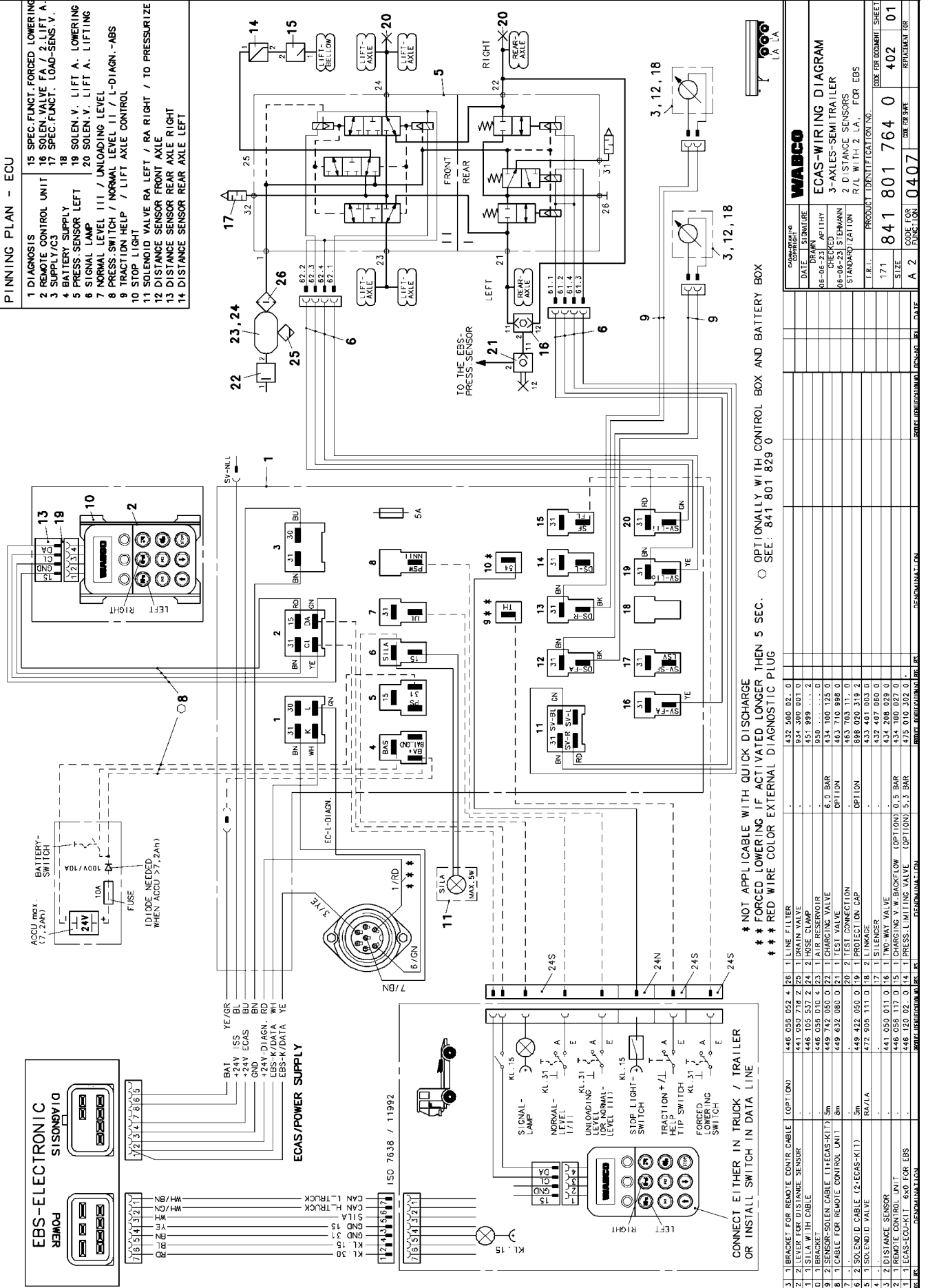

List of Parameters Trailer ECAS

ECU Variant: 446 055 066 0

Circuit Diagram No.: 841 801 765 0

Parameter Record No.: 8418017650

Par.		Value	Unit
P 0	=	18	
P 1	=	12	
P 2	=	12	
P 3	=	252	
P 4	=	0	
P 5	=	0	counts
P 6	=	15	counts
P 7	=	0	counts
P 8	=	115	counts
P 9	=	0	counts
P10	=	5	counts
P11	=	6	counts
P12	=	255	counts
P13	=	255	counts
P14	=	20	counts
P15	=	15	k.p.h.
P16	=	8	250ms
P17	=	12	25ms
P18	=	80	250ms
P19	=	0	1/3counts

Par.		Value	Unit
P20	=	10	1/3counts
P21	=	0	1/3counts
P22	=	20	1/3counts
P23	=	0	counts
P24	=	115	counts
P25	=	255	k.p.h.
P26	=	0	k.p.h.
P27	=	240	250ms
P28	=	0	1/16bar
P29	=	0	1/16bar
P30	=	255	1/16bar
P31	=	0	k.p.h.
P32	=	0	5s
P33	=	0	5s
P34	=	0	5s
P35	=	0	k.p.h.
P36	=	0	k.p.h.
P37	=	0	1/16bar
P38	=	0	1/16bar
P39	=	0	counts

Par.		Value	Unit
P40	=	120	10s
P41	=	20	k.p.h.
P42	=	0	1/16bar
P43	=	0	1/16bar
P44	=	0	counts
P45	=	0	1/16bar
P46	=	0	1/16bar
P47	=	0	10s
P48	=	48	15min
P49	=	10	counts
P50	=	100	300ms
P51	=	0	k.p.h.
P52	=	0	counts

System Description:

semitrailer with two height sensors
 no lifting axle control / traction help
 raising/lowering from remote-control unit up to calibrated upper value and mechanical stop at bottom
 automatic driving level from 20 k.p.h.
 3 driving levels selectable from remote-control unit
 DL III > DL I > DL II
 remote-control unit cleared up to 15 k.p.h.
 2 freely programmable memory levels via remote-control unit
 2 seconds control delay while stationary and 60 seconds when in motion
 power supply from WABCO EBS

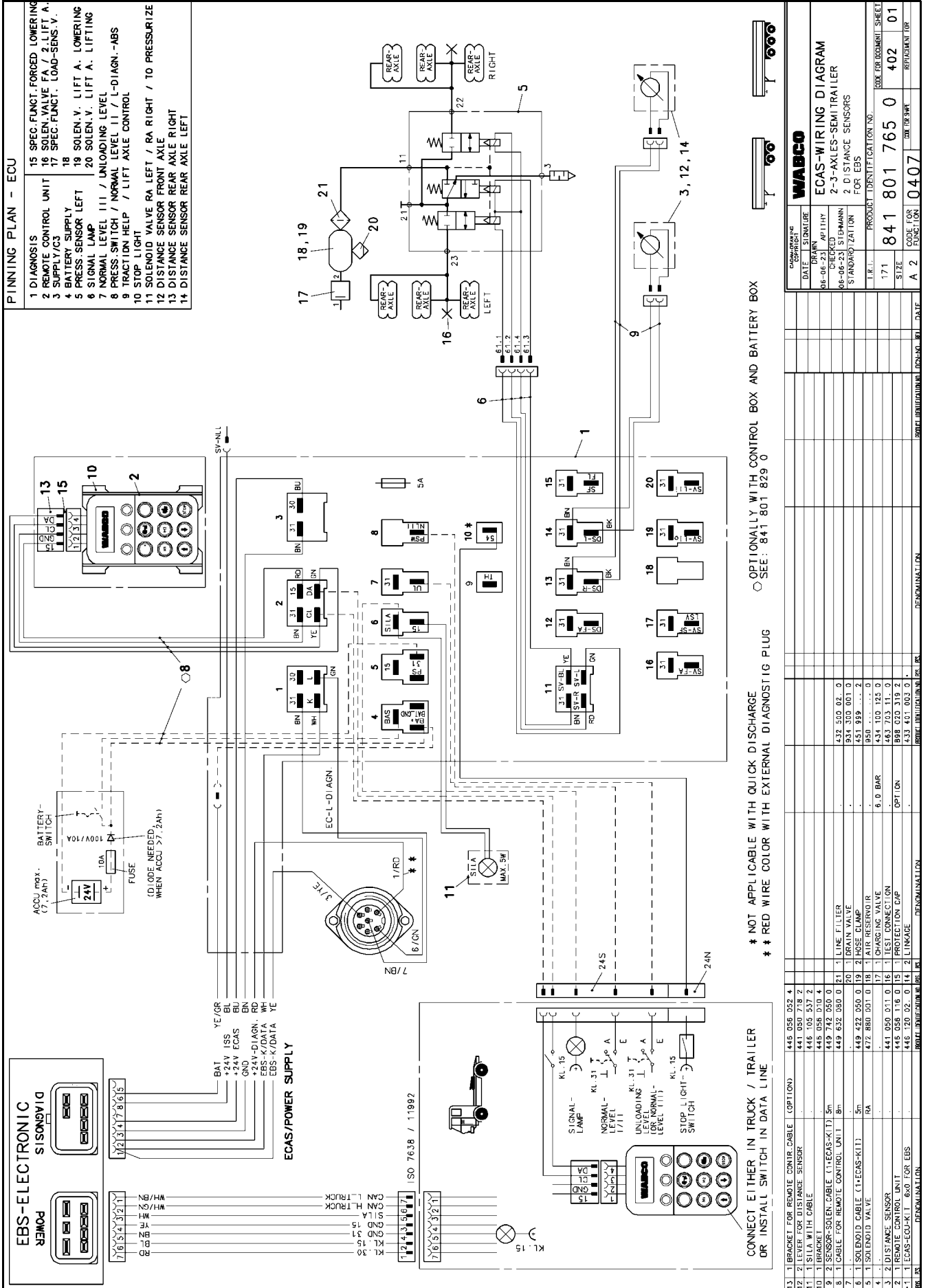

WABCO	
DATE	15/11/11
CHECKED	AP 11111
STANDARDIZATION	2-3 AXLES-SEMI TRAILER
PRODUCT IDENTIFICATION NO.	841 801 765 0
SIZE	A 2
CODE FOR FUNCTION	0407

REF. LINE	DESCRIPTION	REF. LINE	DESCRIPTION
3.1	BRACKET FOR REMOTE CONTR. CABLE (OPTION)	445 056 052 4	
3.2	LEVER FOR DISTANCE SENSOR	441 050 718 2	
4	SILA WITH CABLE	445 056 070 4	
5	BRACKET	445 056 070 4	
6	SENSOR-SOLEN. CABLE (1+ECAS-K1)	449 742 050 0	
7	CABLE FOR REMOTE CONTROL UNIT	449 632 050 0	
8	SOLENOID VALVE	449 422 050 0	
9	SOLENOID VALVE	449 422 050 0	
10	SOLENOID VALVE	449 422 050 0	
11	SOLENOID VALVE	449 422 050 0	
12	DISTANCE SENSOR	441 050 011 0	
13	REMOTE CONTROL UNIT	445 056 116 0	
14	ECAS-ECU-K1 6x0 FOR EBS	445 120 02 0	
15	PROTECTION CAP	445 056 116 0	
16	LINKAGE	445 431 003 0	
17	LINKAGE	445 431 003 0	
18	LINKAGE	445 431 003 0	
19	LINKAGE	445 431 003 0	
20	LINKAGE	445 431 003 0	
21	LINKAGE	445 431 003 0	
22	LINKAGE	445 431 003 0	
23	LINKAGE	445 431 003 0	
24	LINKAGE	445 431 003 0	
25	LINKAGE	445 431 003 0	
26	LINKAGE	445 431 003 0	
27	LINKAGE	445 431 003 0	
28	LINKAGE	445 431 003 0	
29	LINKAGE	445 431 003 0	
30	LINKAGE	445 431 003 0	
31	LINKAGE	445 431 003 0	
32	LINKAGE	445 431 003 0	
33	LINKAGE	445 431 003 0	
34	LINKAGE	445 431 003 0	
35	LINKAGE	445 431 003 0	
36	LINKAGE	445 431 003 0	
37	LINKAGE	445 431 003 0	
38	LINKAGE	445 431 003 0	
39	LINKAGE	445 431 003 0	
40	LINKAGE	445 431 003 0	
41	LINKAGE	445 431 003 0	
42	LINKAGE	445 431 003 0	
43	LINKAGE	445 431 003 0	
44	LINKAGE	445 431 003 0	
45	LINKAGE	445 431 003 0	
46	LINKAGE	445 431 003 0	
47	LINKAGE	445 431 003 0	
48	LINKAGE	445 431 003 0	
49	LINKAGE	445 431 003 0	
50	LINKAGE	445 431 003 0	
51	LINKAGE	445 431 003 0	
52	LINKAGE	445 431 003 0	
53	LINKAGE	445 431 003 0	
54	LINKAGE	445 431 003 0	
55	LINKAGE	445 431 003 0	
56	LINKAGE	445 431 003 0	
57	LINKAGE	445 431 003 0	
58	LINKAGE	445 431 003 0	
59	LINKAGE	445 431 003 0	
60	LINKAGE	445 431 003 0	
61	LINKAGE	445 431 003 0	
62	LINKAGE	445 431 003 0	
63	LINKAGE	445 431 003 0	
64	LINKAGE	445 431 003 0	
65	LINKAGE	445 431 003 0	
66	LINKAGE	445 431 003 0	
67	LINKAGE	445 431 003 0	
68	LINKAGE	445 431 003 0	
69	LINKAGE	445 431 003 0	
70	LINKAGE	445 431 003 0	
71	LINKAGE	445 431 003 0	
72	LINKAGE	445 431 003 0	
73	LINKAGE	445 431 003 0	
74	LINKAGE	445 431 003 0	
75	LINKAGE	445 431 003 0	
76	LINKAGE	445 431 003 0	
77	LINKAGE	445 431 003 0	
78	LINKAGE	445 431 003 0	
79	LINKAGE	445 431 003 0	
80	LINKAGE	445 431 003 0	
81	LINKAGE	445 431 003 0	
82	LINKAGE	445 431 003 0	
83	LINKAGE	445 431 003 0	
84	LINKAGE	445 431 003 0	
85	LINKAGE	445 431 003 0	
86	LINKAGE	445 431 003 0	
87	LINKAGE	445 431 003 0	
88	LINKAGE	445 431 003 0	
89	LINKAGE	445 431 003 0	
90	LINKAGE	445 431 003 0	
91	LINKAGE	445 431 003 0	
92	LINKAGE	445 431 003 0	
93	LINKAGE	445 431 003 0	
94	LINKAGE	445 431 003 0	
95	LINKAGE	445 431 003 0	
96	LINKAGE	445 431 003 0	
97	LINKAGE	445 431 003 0	
98	LINKAGE	445 431 003 0	
99	LINKAGE	445 431 003 0	
100	LINKAGE	445 431 003 0	

List of Parameters Trailer ECAS

ECU Variant: 446 055 066 0

Circuit Diagram No.: 841 801 766 0

Parameter Record No.: 8418017660

Par.	Value	Unit
P 0	= 18	
P 1	= 24	
P 2	= 77	
P 3	= 92	
P 4	= 5	
P 5	= 0	counts
P 6	= 160	counts
P 7	= 0	counts
P 8	= 115	counts
P 9	= 0	counts
P10	= 5	counts
P11	= 255	counts
P12	= 255	counts
P13	= 255	counts
P14	= 20	counts
P15	= 15	k.p.h.
P16	= 8	250ms
P17	= 12	25ms
P18	= 80	250ms
P19	= 0	1/3counts

Par.	Value	Unit
P20	= 10	1/3counts
P21	= 0	1/3counts
P22	= 20	1/3counts
P23	= 0	counts
P24	= 15	counts
P25	= 255	k.p.h.
P26	= 0	k.p.h.
P27	= 240	250ms
P28	= 64	1/16bar
P29	= 38	1/16bar
P30	= 96	1/16bar
P31	= 20	k.p.h.
P32	= 18	5s
P33	= 255	5s
P34	= 0	5s
P35	= 20	k.p.h.
P36	= 30	k.p.h.
P37	= 83	1/16bar
P38	= 4	1/16bar
P39	= 10	counts

Par.	Value	Unit
P40	= 120	10s
P41	= 20	k.p.h.
P42	= 0	1/16bar
P43	= 0	1/16bar
P44	= 0	counts
P45	= 17	1/16bar
P46	= 25	1/16bar
P47	= 30	10s
P48	= 48	15min
P49	= 10	counts
P50	= 100	300ms
P51	= 20	k.p.h.
P52	= 10	counts

System Description:

- semitrailer with one height sensor
- automatic lifting axle control for two separate lifting axles and EC traction help on Axle 1
- lowering of lifting axle(s) at a pressure of 4 bar in the supporting bellows
- raising the first lifting axle at a pressure of 2.4 bar in the supporting bellows
- raising the second lifting axle at a pressure of 1.6 bar in the supporting bellows
- simultaneously raising both lifting axle up to a pressure of 1.1 bar in the supporting bellows
- lowering to the buffers due to 50% excess weight at a pressure of 6 bar in the supporting bellows
- traction help pressure of 5.2 bar in the supporting bellows
- starting traction help via remote-control unit or rocking switch
- ending traction help by pushing Stop button or holding rocking switch down for more than 5 sec. or Vlimit > 30 k.p.h.
- lifting axle is lowered after ignition OFF
- lifting axle(s) is (are) raised after vehicle was stopped once and subsequently moved at >20 k.p.h. up to 2.4 bar
- raising the level by 10 counts at driving level for improved tyre clearance when lifting axle is raised
- raising the level by 10 counts when traction help is active
- unloading level to buffer when switch has been activated (160 counts)
- raising/lowering from remote-control unit up to calibrated upper value and mechanical stop at bottom
- automatic driving level from 20 k.p.h.
- 2 driving levels selectable from remote-control unit
- DL II > DL I
- remote-control unit cleared up to 15 k.p.h
- 2 freely programmable memory levels via remote-control unit
- 2 seconds control delay while stationary and 60 seconds when in motion
- power supply from WABCO EBS

bellows pressure laden 4.0 bar

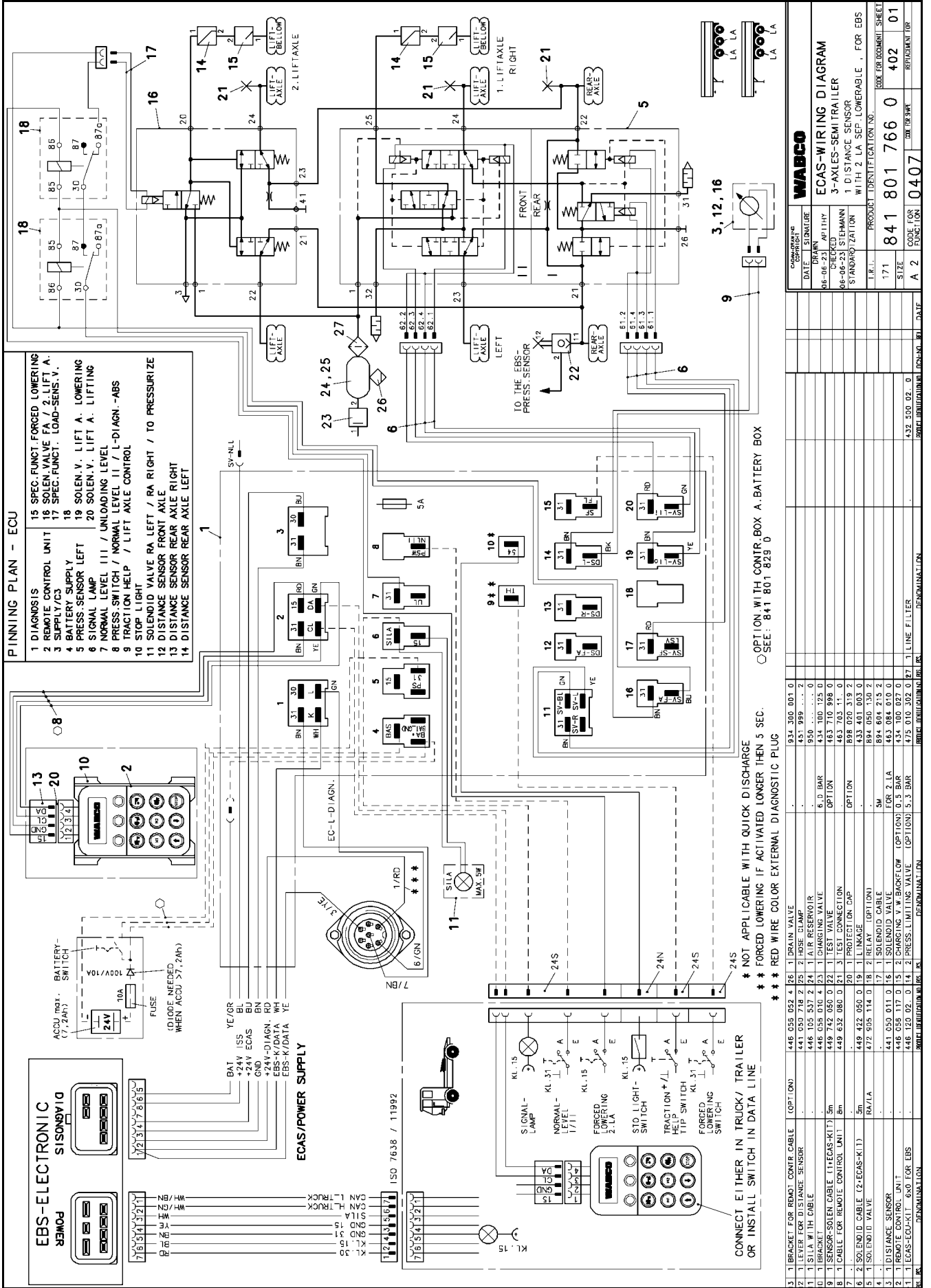

WABCO	
DATE: 06-06-2011	APPROVED: [Signature]
CHECKED: 06-06-2011	STEFMANN
1 DISTANCE SENSOR WITH 2 LA SEP. LOWERABLE, FOR EBS	
PRODUCT IDENTIFICATION NO.	
T.R.T. 171	841 801 766 0
SIZE	402
CODE FOR FUNCTION	A 2
REF. PART NO.	0407

REF. PART NO.	DESCRIPTION	QTY	UNIT	DATE
934 300 001 0	...	2		
431 959 ... 2	...	2		
950 ... 0	...	0		
434 100 125 0	6. D BAR	1		
463 710 898 0	OPTION	1		
463 703 11 0	OPTION	1		
898 070 319 2	...	2		
433 401 003 0	...	0		
894 604 213 2	SW	2		
463 084 010 0	FOR 2 LA	0		
434 100 027 0	OPTION	0,5		
475 010 302 0 27	1 LINE FILTER	1		

List of Parameters Trailer ECAS

ECU Variant: 446 055 066 0

Circuit Diagram No.: 841 801 767 0

Parameter Record No.: 8418017670

Par.		Value	Unit
P 0	=	18	
P 1	=	62	
P 2	=	13	
P 3	=	252	
P 4	=	0	
P 5	=	15	counts
P 6	=	15	counts
P 7	=	115	counts
P 8	=	115	counts
P 9	=	5	counts
P10	=	5	counts
P11	=	255	counts
P12	=	255	counts
P13	=	255	counts
P14	=	20	counts
P15	=	15	k.p.h.
P16	=	8	250ms
P17	=	12	25ms
P18	=	80	250ms
P19	=	10	1/3counts

Par.		Value	Unit
P20	=	10	1/3counts
P21	=	20	1/3counts
P22	=	20	1/3counts
P23	=	115	counts
P24	=	115	counts
P25	=	255	k.p.h.
P26	=	0	k.p.h.
P27	=	240	250ms
P28	=	0	1/16bar
P29	=	0	1/16bar
P30	=	255	1/16bar
P31	=	0	k.p.h.
P32	=	0	5s
P33	=	0	5s
P34	=	0	5s
P35	=	0	k.p.h.
P36	=	0	k.p.h.
P37	=	0	1/16bar
P38	=	0	1/16bar
P39	=	0	counts

Par.		Value	Unit
P40	=	120	10s
P41	=	20	k.p.h.
P42	=	0	1/16bar
P43	=	0	1/16bar
P44	=	0	counts
P45	=	0	1/16bar
P46	=	0	1/16bar
P47	=	0	10s
P48	=	48	15min
P49	=	10	counts
P50	=	100	300ms
P51	=	0	k.p.h.
P52	=	0	counts

System Description:

semitrailer with two height sensors
 no lifting axle control / traction help
 raising/lowering from remote-control unit up to calibrated upper value and mechanical stop at bottom
 automatic driving level from 20 k.p.h.
 3 driving levels selectable from remote-control unit
 DL III > DL I > DL II
 remote-control unit cleared up to 15 k.p.h.
 left/right control of vehicle possible from remote-control unit (raise/lower) (left = front, right = rear)
 2 freely programmable memory levels via remote-control unit
 2 seconds control delay while stationary and 60 seconds when in motion
 power supply from WABCO EBS

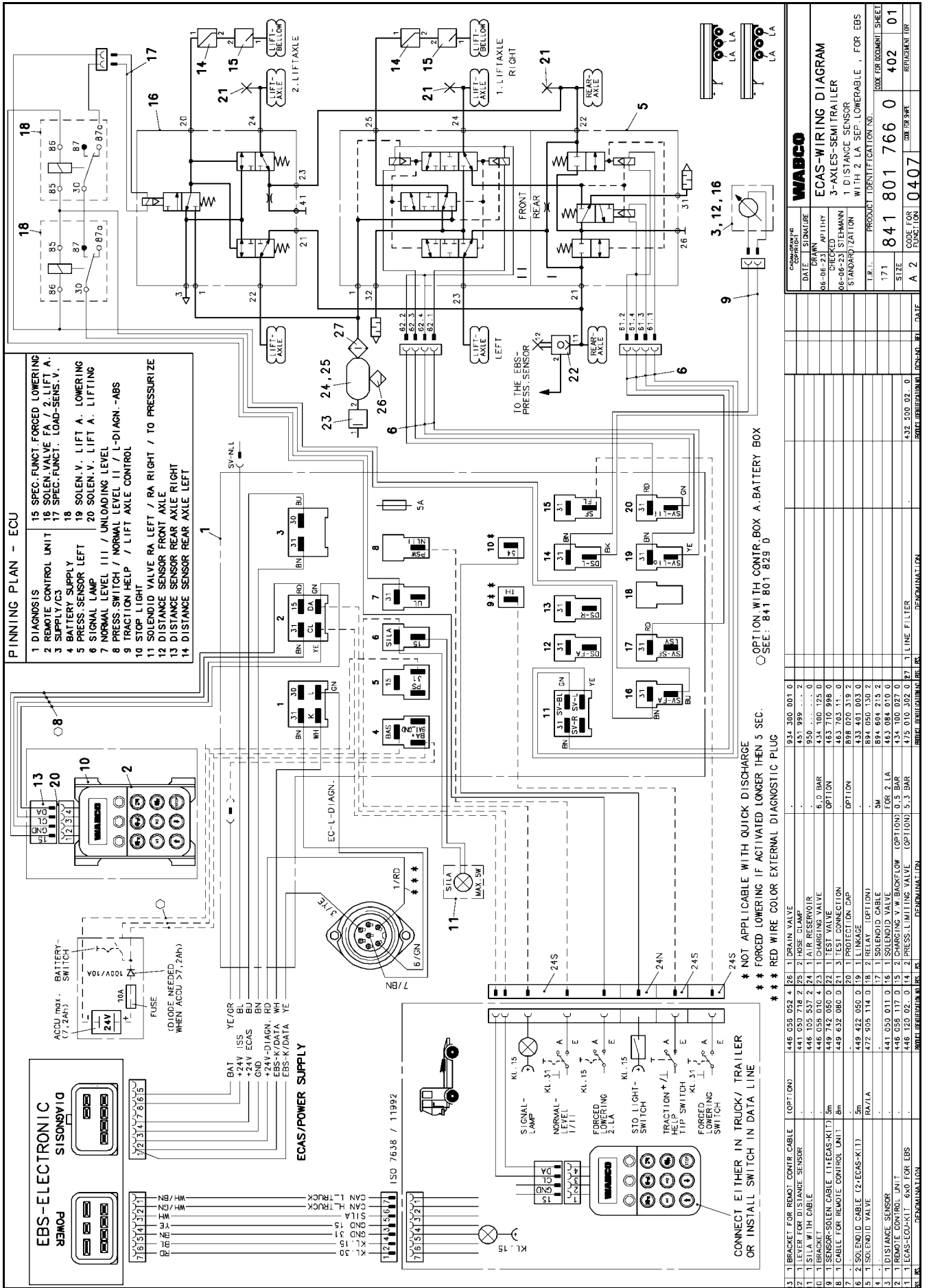

DATE	DESCRIPTION	BY	DATE	DESCRIPTION	BY
06-06-23	ECAS-WIRING DIAGRAM	LA	06-06-23	ECAS-WIRING DIAGRAM	LA
06-06-23	CHECKED	LA	06-06-23	CHECKED	LA
06-06-23	STANDARDIZATION	LA	06-06-23	STANDARDIZATION	LA
171	PRODUCT IDENTIFICATION NO.		432 350 02.0	PRODUCT IDENTIFICATION NO.	
841 801 766 0	SIZE		432 350 02.0	SIZE	
A 2	CODE FOR SHEET		432 350 02.0	CODE FOR SHEET	
0407	REF. FUNCTION		432 350 02.0	REF. FUNCTION	

List of Parameters Trailer ECAS

ECU Variant: 446 055 066 0

Circuit Diagram No.: 841 801 768 0

Parameter Record No.: 8418017680

Par.	Value	Unit
P 0	= 18	
P 1	= 26	
P 2	= 13	
P 3	= 124	
P 4	= 5	
P 5	= 15	counts
P 6	= 15	counts
P 7	= 115	counts
P 8	= 115	counts
P 9	= 5	counts
P10	= 5	counts
P11	= 255	counts
P12	= 255	counts
P13	= 15	counts
P14	= 20	counts
P15	= 15	k.p.h.
P16	= 8	250ms
P17	= 12	25ms
P18	= 80	250ms
P19	= 10	1/3counts

Par.	Value	Unit
P20	= 10	1/3counts
P21	= 20	1/3counts
P22	= 20	1/3counts
P23	= 115	counts
P24	= 115	counts
P25	= 255	k.p.h.
P26	= 0	k.p.h.
P27	= 240	250ms
P28	= 64	1/16bar
P29	= 38	1/16bar
P30	= 96	1/16bar
P31	= 20	k.p.h.
P32	= 18	5s
P33	= 255	5s
P34	= 0	5s
P35	= 20	k.p.h.
P36	= 30	k.p.h.
P37	= 83	1/16bar
P38	= 4	1/16bar
P39	= 10	counts

Par.	Value	Unit
P40	= 120	10s
P41	= 20	k.p.h.
P42	= 0	1/16bar
P43	= 0	1/16bar
P44	= 0	counts
P45	= 0	1/16bar
P46	= 0	1/16bar
P47	= 0	10s
P48	= 48	15min
P49	= 10	counts
P50	= 100	300ms
P51	= 20	k.p.h.
P52	= 10	counts

System Description:

semitrailer with two height sensors
 automatic lifting axle control and EC traction help
 lowering of lifting axle at a pressure of 4 bar in the supporting bellows
 raising the lifting axle up to a pressure of 2.4 bar in the supporting bellows
 lowering to the buffers due to 50% excess weight at a pressure of 6 bar in the supporting bellows
 traction help pressure of 5.2 bar in the supporting bellows
 starting traction help via remote-control unit or rocking switch
 ending traction help by pushing Stop button or holding rocking switch down for more than 5 sec. or Vlimit > 30 k.p.h.
 lifting axle is lowered after ignition OFF
 lifting axle is raised after vehicle was stopped once and subsequently moved at >20 k.p.h. up to 2.4 bar
 raising the level by 10 counts at driving level for improved tyre clearance when lifting axle is raised
 raising the level by 10 counts when traction help is active
 raising/lowering from remote-control unit up to calibrated upper value and mechanical stop at bottom
 automatic driving level from 20 k.p.h.
 3 driving levels selectable from remote-control unit
 DL III > DL I > DL II
 remote-control unit cleared up to 15 k.p.h.
 2 freely programmable memory levels via remote-control unit
 2 seconds control delay while stationary and 60 seconds when in motion
 power supply from WABCO EBS

bellows pressure laden 4.0 bar

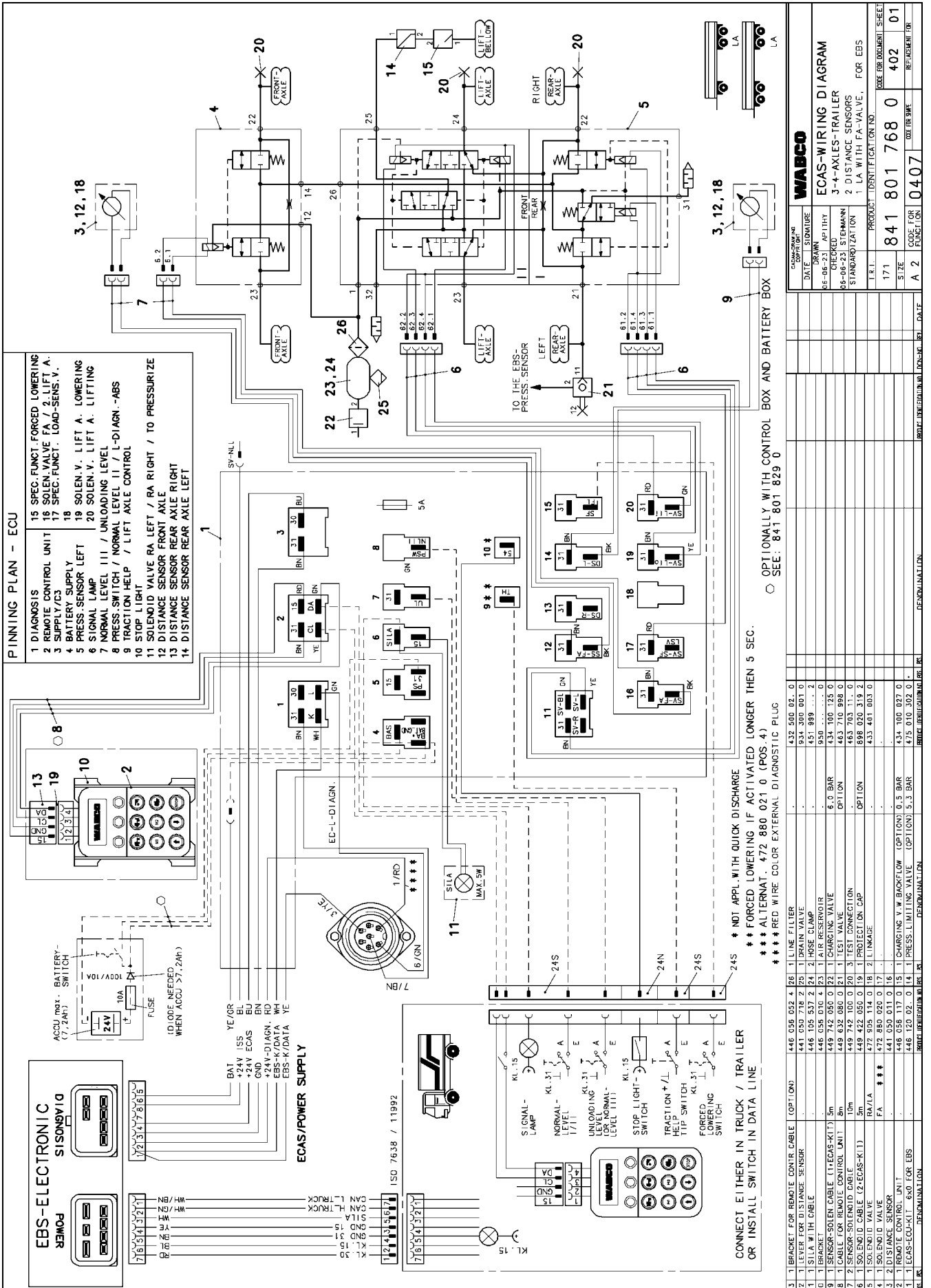

DATE	SIGNATURE	WABCO
06-06-23	STEHMANN	ECAS-WIRING DIAGRAM
06-06-23	STEHMANN	3-4 AXLES-TRAILER
06-06-23	STEHMANN	2 DISTANCE SENSORS
06-06-23	STEHMANN	1 LA WITH FA-VALVE. FOR EBS
171	841 801 768 0	CODE FOR DOCUMENT SHEET
A 2	402	REF. PART NO.
A 2	01	REVISION FOR

NO.	DESCRIPTION	QTY.	UNIT	REVISION
1	ECAS-ECU-KIT 6x0 FOR EBS	1	ECU	
2	ECAS-ECU-KIT 6x0 FOR EBS	1	ECU	
3	1 BRACKET FOR REMOTE CONTROL CABLE (OPTION)	1	BRACKET	
4	1 LEVER FOR DISTANCE SENSOR	1	LEVER	
5	1 SILVA WITH CABLE	1	SILVA	
6	1 BRACKET	1	BRACKET	
7	1 SENSOR-SOLEN VALVE (1-ECAS-K11) 5m	1	SENSOR-SOLEN VALVE	
8	1 CABLE FOR REMOTE CONTROL UNIT	1	CABLE	
9	1 SENSOR-SOLEN VALVE (2-ECAS-K11) 5m	1	SENSOR-SOLEN VALVE	
10	1 CABLE FOR REMOTE CONTROL UNIT	1	CABLE	
11	1 SOLENOID VALVE (1-ECAS-K11) 5m	1	SOLENOID VALVE	
12	1 SOLENOID VALVE (2-ECAS-K11) 5m	1	SOLENOID VALVE	
13	1 SOLENOID VALVE (1-ECAS-K11) 5m	1	SOLENOID VALVE	
14	1 SOLENOID VALVE (2-ECAS-K11) 5m	1	SOLENOID VALVE	
15	1 REMOTE CONTROL UNIT	1	REMOTE CONTROL UNIT	
16	1 REMOTE CONTROL UNIT	1	REMOTE CONTROL UNIT	
17	1 SOLENOID VALVE (1-ECAS-K11) 5m	1	SOLENOID VALVE	
18	1 SOLENOID VALVE (2-ECAS-K11) 5m	1	SOLENOID VALVE	
19	1 SOLENOID VALVE (1-ECAS-K11) 5m	1	SOLENOID VALVE	
20	1 SOLENOID VALVE (2-ECAS-K11) 5m	1	SOLENOID VALVE	
21	1 SOLENOID VALVE (1-ECAS-K11) 5m	1	SOLENOID VALVE	
22	1 SOLENOID VALVE (2-ECAS-K11) 5m	1	SOLENOID VALVE	
23	1 SOLENOID VALVE (1-ECAS-K11) 5m	1	SOLENOID VALVE	
24	1 SOLENOID VALVE (2-ECAS-K11) 5m	1	SOLENOID VALVE	
25	1 SOLENOID VALVE (1-ECAS-K11) 5m	1	SOLENOID VALVE	
26	1 SOLENOID VALVE (2-ECAS-K11) 5m	1	SOLENOID VALVE	
27	1 SOLENOID VALVE (1-ECAS-K11) 5m	1	SOLENOID VALVE	
28	1 SOLENOID VALVE (2-ECAS-K11) 5m	1	SOLENOID VALVE	
29	1 SOLENOID VALVE (1-ECAS-K11) 5m	1	SOLENOID VALVE	
30	1 SOLENOID VALVE (2-ECAS-K11) 5m	1	SOLENOID VALVE	
31	1 SOLENOID VALVE (1-ECAS-K11) 5m	1	SOLENOID VALVE	
32	1 SOLENOID VALVE (2-ECAS-K11) 5m	1	SOLENOID VALVE	
33	1 SOLENOID VALVE (1-ECAS-K11) 5m	1	SOLENOID VALVE	
34	1 SOLENOID VALVE (2-ECAS-K11) 5m	1	SOLENOID VALVE	
35	1 SOLENOID VALVE (1-ECAS-K11) 5m	1	SOLENOID VALVE	
36	1 SOLENOID VALVE (2-ECAS-K11) 5m	1	SOLENOID VALVE	
37	1 SOLENOID VALVE (1-ECAS-K11) 5m	1	SOLENOID VALVE	
38	1 SOLENOID VALVE (2-ECAS-K11) 5m	1	SOLENOID VALVE	
39	1 SOLENOID VALVE (1-ECAS-K11) 5m	1	SOLENOID VALVE	
40	1 SOLENOID VALVE (2-ECAS-K11) 5m	1	SOLENOID VALVE	
41	1 SOLENOID VALVE (1-ECAS-K11) 5m	1	SOLENOID VALVE	
42	1 SOLENOID VALVE (2-ECAS-K11) 5m	1	SOLENOID VALVE	
43	1 SOLENOID VALVE (1-ECAS-K11) 5m	1	SOLENOID VALVE	
44	1 SOLENOID VALVE (2-ECAS-K11) 5m	1	SOLENOID VALVE	
45	1 SOLENOID VALVE (1-ECAS-K11) 5m	1	SOLENOID VALVE	
46	1 SOLENOID VALVE (2-ECAS-K11) 5m	1	SOLENOID VALVE	
47	1 SOLENOID VALVE (1-ECAS-K11) 5m	1	SOLENOID VALVE	
48	1 SOLENOID VALVE (2-ECAS-K11) 5m	1	SOLENOID VALVE	
49	1 SOLENOID VALVE (1-ECAS-K11) 5m	1	SOLENOID VALVE	
50	1 SOLENOID VALVE (2-ECAS-K11) 5m	1	SOLENOID VALVE	
51	1 SOLENOID VALVE (1-ECAS-K11) 5m	1	SOLENOID VALVE	
52	1 SOLENOID VALVE (2-ECAS-K11) 5m	1	SOLENOID VALVE	
53	1 SOLENOID VALVE (1-ECAS-K11) 5m	1	SOLENOID VALVE	
54	1 SOLENOID VALVE (2-ECAS-K11) 5m	1	SOLENOID VALVE	
55	1 SOLENOID VALVE (1-ECAS-K11) 5m	1	SOLENOID VALVE	
56	1 SOLENOID VALVE (2-ECAS-K11) 5m	1	SOLENOID VALVE	
57	1 SOLENOID VALVE (1-ECAS-K11) 5m	1	SOLENOID VALVE	
58	1 SOLENOID VALVE (2-ECAS-K11) 5m	1	SOLENOID VALVE	
59	1 SOLENOID VALVE (1-ECAS-K11) 5m	1	SOLENOID VALVE	
60	1 SOLENOID VALVE (2-ECAS-K11) 5m	1	SOLENOID VALVE	
61	1 SOLENOID VALVE (1-ECAS-K11) 5m	1	SOLENOID VALVE	
62	1 SOLENOID VALVE (2-ECAS-K11) 5m	1	SOLENOID VALVE	
63	1 SOLENOID VALVE (1-ECAS-K11) 5m	1	SOLENOID VALVE	
64	1 SOLENOID VALVE (2-ECAS-K11) 5m	1	SOLENOID VALVE	
65	1 SOLENOID VALVE (1-ECAS-K11) 5m	1	SOLENOID VALVE	
66	1 SOLENOID VALVE (2-ECAS-K11) 5m	1	SOLENOID VALVE	
67	1 SOLENOID VALVE (1-ECAS-K11) 5m	1	SOLENOID VALVE	
68	1 SOLENOID VALVE (2-ECAS-K11) 5m	1	SOLENOID VALVE	
69	1 SOLENOID VALVE (1-ECAS-K11) 5m	1	SOLENOID VALVE	
70	1 SOLENOID VALVE (2-ECAS-K11) 5m	1	SOLENOID VALVE	
71	1 SOLENOID VALVE (1-ECAS-K11) 5m	1	SOLENOID VALVE	
72	1 SOLENOID VALVE (2-ECAS-K11) 5m	1	SOLENOID VALVE	
73	1 SOLENOID VALVE (1-ECAS-K11) 5m	1	SOLENOID VALVE	
74	1 SOLENOID VALVE (2-ECAS-K11) 5m	1	SOLENOID VALVE	
75	1 SOLENOID VALVE (1-ECAS-K11) 5m	1	SOLENOID VALVE	
76	1 SOLENOID VALVE (2-ECAS-K11) 5m	1	SOLENOID VALVE	
77	1 SOLENOID VALVE (1-ECAS-K11) 5m	1	SOLENOID VALVE	
78	1 SOLENOID VALVE (2-ECAS-K11) 5m	1	SOLENOID VALVE	
79	1 SOLENOID VALVE (1-ECAS-K11) 5m	1	SOLENOID VALVE	
80	1 SOLENOID VALVE (2-ECAS-K11) 5m	1	SOLENOID VALVE	
81	1 SOLENOID VALVE (1-ECAS-K11) 5m	1	SOLENOID VALVE	
82	1 SOLENOID VALVE (2-ECAS-K11) 5m	1	SOLENOID VALVE	
83	1 SOLENOID VALVE (1-ECAS-K11) 5m	1	SOLENOID VALVE	
84	1 SOLENOID VALVE (2-ECAS-K11) 5m	1	SOLENOID VALVE	
85	1 SOLENOID VALVE (1-ECAS-K11) 5m	1	SOLENOID VALVE	
86	1 SOLENOID VALVE (2-ECAS-K11) 5m	1	SOLENOID VALVE	
87	1 SOLENOID VALVE (1-ECAS-K11) 5m	1	SOLENOID VALVE	
88	1 SOLENOID VALVE (2-ECAS-K11) 5m	1	SOLENOID VALVE	
89	1 SOLENOID VALVE (1-ECAS-K11) 5m	1	SOLENOID VALVE	
90	1 SOLENOID VALVE (2-ECAS-K11) 5m	1	SOLENOID VALVE	
91	1 SOLENOID VALVE (1-ECAS-K11) 5m	1	SOLENOID VALVE	
92	1 SOLENOID VALVE (2-ECAS-K11) 5m	1	SOLENOID VALVE	
93	1 SOLENOID VALVE (1-ECAS-K11) 5m	1	SOLENOID VALVE	
94	1 SOLENOID VALVE (2-ECAS-K11) 5m	1	SOLENOID VALVE	
95	1 SOLENOID VALVE (1-ECAS-K11) 5m	1	SOLENOID VALVE	
96	1 SOLENOID VALVE (2-ECAS-K11) 5m	1	SOLENOID VALVE	
97	1 SOLENOID VALVE (1-ECAS-K11) 5m	1	SOLENOID VALVE	
98	1 SOLENOID VALVE (2-ECAS-K11) 5m	1	SOLENOID VALVE	
99	1 SOLENOID VALVE (1-ECAS-K11) 5m	1	SOLENOID VALVE	
100	1 SOLENOID VALVE (2-ECAS-K11) 5m	1	SOLENOID VALVE	

List of Parameters Trailer ECAS

ECU Variant: 446 055 066 0

Circuit Diagram No.: 841 801 769 0**Parameter Record No.:** 8418017690

Par.		Value	Unit
P 0	=	18	
P 1	=	24	
P 2	=	13	
P 3	=	92	
P 4	=	5	
P 5	=	0	counts
P 6	=	160	counts
P 7	=	0	counts
P 8	=	115	counts
P 9	=	0	counts
P10	=	5	counts
P11	=	255	counts
P12	=	255	counts
P13	=	255	counts
P14	=	20	counts
P15	=	15	km/h
P16	=	8	250ms
P17	=	12	25ms
P18	=	80	250ms
P19	=	0	1/3counts

Par.		Value	Unit
P20	=	10	1/3counts
P21	=	0	1/3counts
P22	=	20	1/3counts
P23	=	0	counts
P24	=	15	counts
P25	=	255	km/h
P26	=	0	km/h
P27	=	240	250ms
P28	=	64	1/16bar
P29	=	17	1/16bar
P30	=	96	1/16bar
P31	=	20	km/h
P32	=	18	5s
P33	=	255	5s
P34	=	0	5s
P35	=	20	km/h
P36	=	30	km/h
P37	=	83	1/16bar
P38	=	4	1/16bar
P39	=	10	counts

Par.		Value	Unit
P40	=	120	10s
P41	=	20	km/h
P42	=	0	1/16bar
P43	=	0	1/16bar
P44	=	0	counts
P45	=	0	1/16bar
P46	=	0	1/16bar
P47	=	30	10s
P48	=	48	15min
P49	=	10	counts
P50	=	100	300ms
P51	=	20	km/h
P52	=	10	counts

System Description:

semitrailer with one height sensor
automatic lifting axle control for two connected in parallel lifting axles and EC traction help
lowering of lifting axle at a pressure of 4 bar in the supporting bellows
raising the lifting axle up to a pressure of 1.1 bar in the supporting bellows
lowering to the buffers due to 50% excess weight at a pressure of 6 bar in the supporting bellows
traction help pressure of 5.2 bar in the supporting bellows
starting traction help via remote-control unit or rocking switch
ending traction help by pushing Stop button or holding rocking switch down for more than 5 sec. or Vlimit > 30 k.p.h.
lifting axle is lowered after ignition OFF
lifting axles are raised after vehicle was stopped once and subsequently moved at >20 k.p.h. up to 1.1 bar
raising the level by 10 counts at driving level for improved tyre clearance when lifting axle is raised
raising the level by 10 counts when traction help is active
unloading level to buffer when switch has been activated (160 counts)
raising/lowering from remote-control unit up to calibrated upper value and mechanical stop at bottom
automatic driving level from 20 k.p.h.
2 driving levels selectable from remote-control unit
DL II > DL I
remote-control unit cleared up to 15 k.p.h.
2 freely programmable memory levels via remote-control unit
2 seconds control delay while stationary and 60 seconds when in motion
power supply from WABCO EBS

bellows pressure laden 4.0 bar

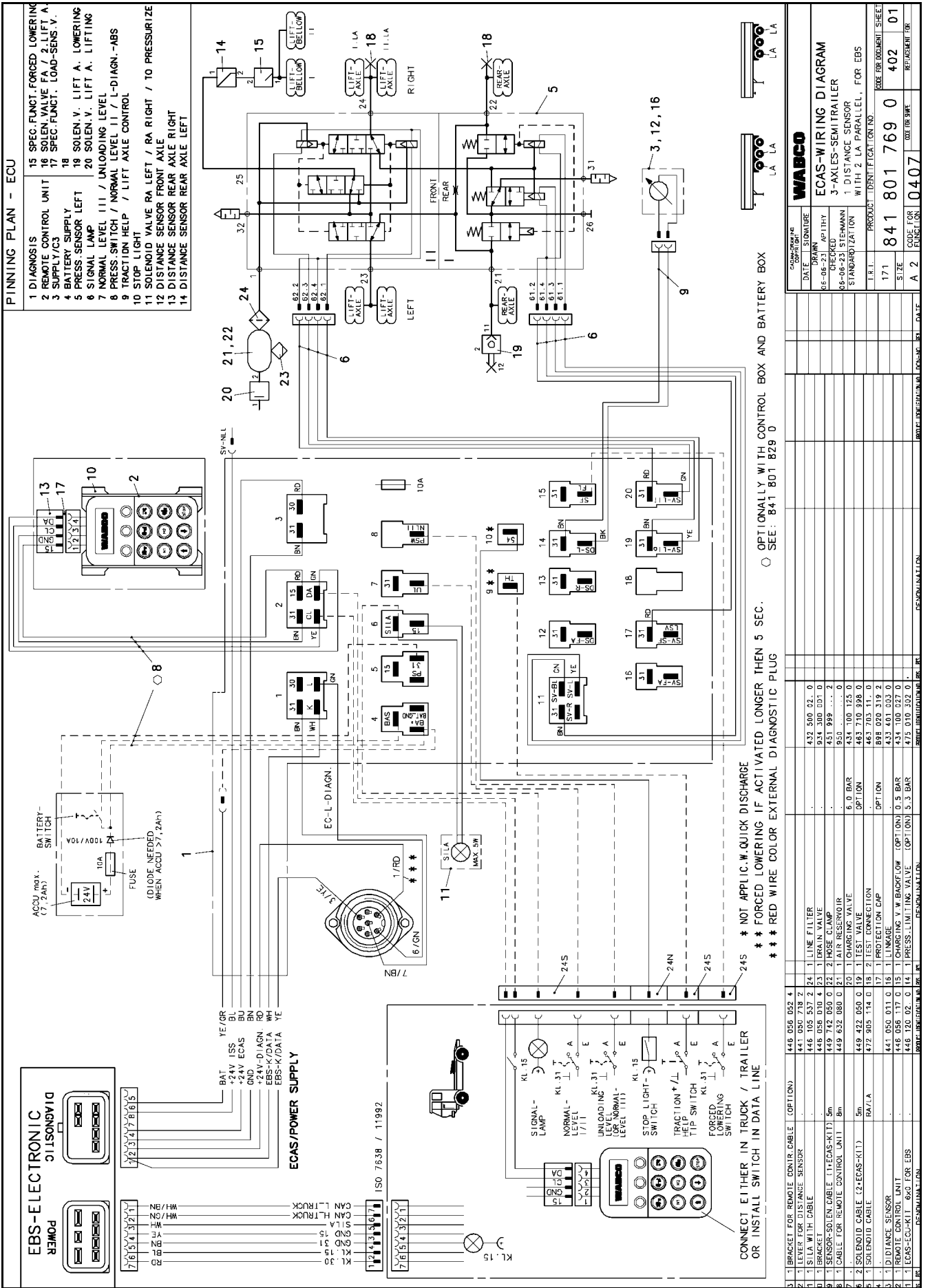

List of Parameters Trailer ECAS

ECU Variant: 446 055 066 0

Circuit Diagram No.: 841 801 820 0

Parameter Record No.: 8418018200

Par.	Value	Unit
P 0	= 18	
P 1	= 30	
P 2	= 13	
P 3	= 124	
P 4	= 0	
P 5	= 15	counts
P 6	= 15	counts
P 7	= 115	counts
P 8	= 115	counts
P 9	= 5	counts
P10	= 5	counts
P11	= 255	counts
P12	= 255	counts
P13	= 15	counts
P14	= 20	counts
P15	= 15	k.p.h.
P16	= 8	250ms
P17	= 12	25ms
P18	= 80	250ms
P19	= 10	1/3counts

Par.	Value	Unit
P20	= 10	1/3counts
P21	= 20	1/3counts
P22	= 20	1/3counts
P23	= 115	counts
P24	= 115	counts
P25	= 255	k.p.h.
P26	= 0	k.p.h.
P27	= 240	250ms
P28	= 0	1/16bar
P29	= 0	1/16bar
P30	= 255	1/16bar
P31	= 0	k.p.h.
P32	= 0	5s
P33	= 0	5s
P34	= 0	5s
P35	= 0	k.p.h.
P36	= 0	k.p.h.
P37	= 0	1/16bar
P38	= 0	1/16bar
P39	= 0	counts

Par.	Value	Unit
P40	= 120	10s
P41	= 20	k.p.h.
P42	= 0	1/16bar
P43	= 0	1/16bar
P44	= 0	counts
P45	= 0	1/16bar
P46	= 0	1/16bar
P47	= 30	10s
P48	= 48	15min
P49	= 10	counts
P50	= 100	300ms
P51	= 0	k.p.h.
P52	= 0	counts

System Description:

drawbar trailer with two height sensors
 no lifting axle control / no traction help
 raising/lowering from remote-control unit up to calibrated upper value and mechanical stop at bottom
 automatic driving level from 20 k.p.h.
 3 driving levels selectable from remote-control unit
 DL III > DL I > DL II
 remote-control unit cleared up to 15 k.p.h.
 2 freely programmable memory levels via remote-control unit
 2 seconds control delay while stationary and 60 seconds when in motion
 no transverse throttle, only 1 solenoid valve, follow pipe lengths/diameters!
 power supply from WABCO EBS

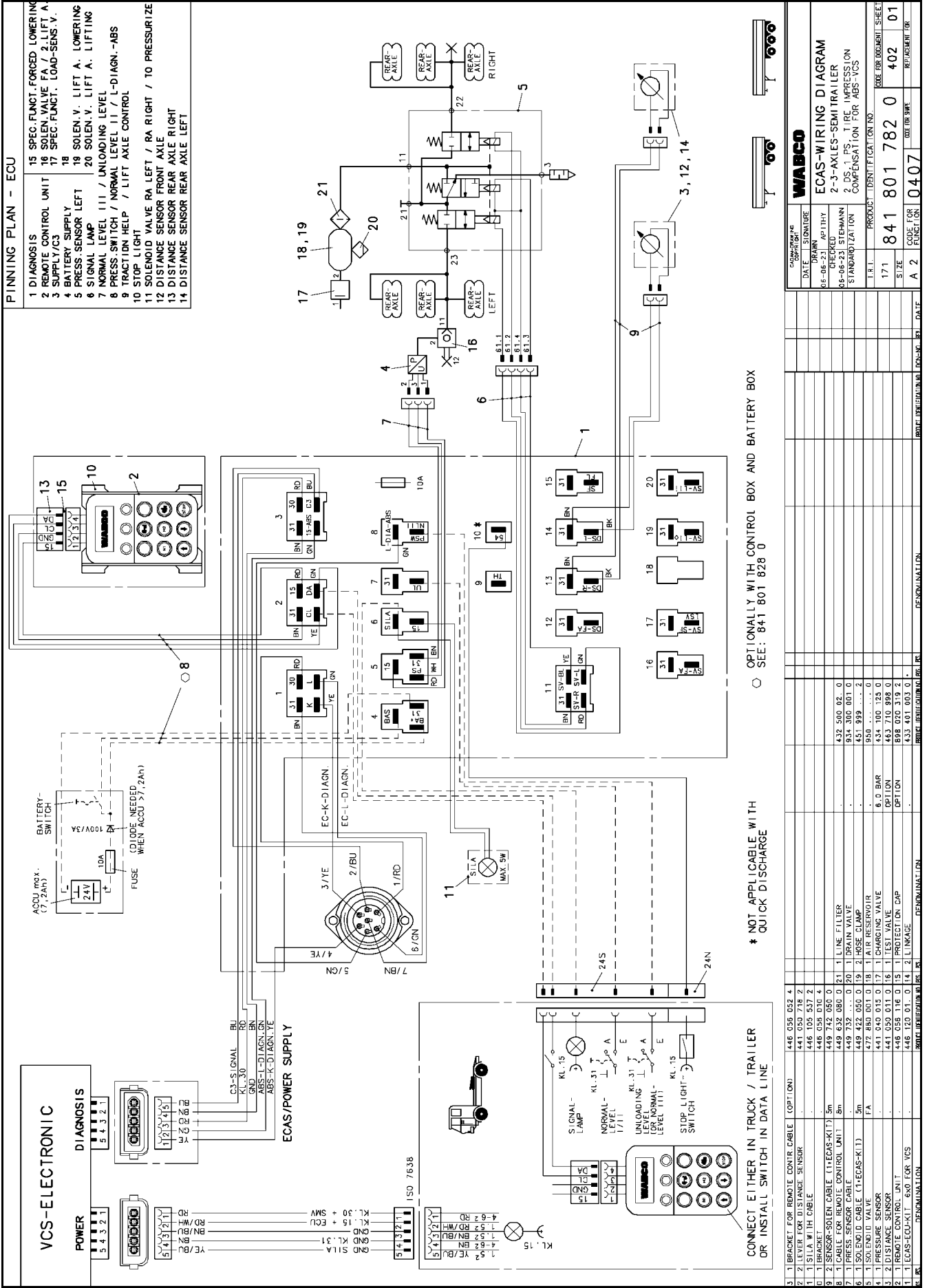

WABCO	
ECAS-WIRING DIAGRAM	
DATE: 06-06-21	APPROVED: AP 11HY
CHECKED: 06-06-23	STEINMANN
STANDARDIZATION	2_DS_1_DS_TIRE_PRESSURON
PRODUCT IDENTIFICATION NO.	COMPENSATION FOR ABS-VCS
171	841 801 782 0
SIZE	006 FOR DOCUMENT SHEET
CODE FOR FUNCTION	0407
CODE FOR REFERENCE FOR	

REF. NO.	DESCRIPTION	UNIT	QTY.	DATE
3	1 BRACKET FOR REMOTE CONTR. CABLE (OPTION)	446 036 032 4		
4	1 LEVER FOR DISTANCE SENSOR	441 030 718 2		
5	1 SILA WITH CABLE	446 105 537 2		
6	1 BRACKET	446 036 016 4		
7	1 SENSOR-SOLEN CABLE (11-ECAS-K17)	449 742 080 0	2	
8	1 CABLE FOR REMOTE CONTROL UNIT	449 632 080 0	2	
9	1 PRESS. SENSOR CABLE	449 732 080 0	2	
10	1 SOLENOID VALVE (11-ECAS-K11)	449 462 080 0	2	
11	1 SOLENOID VALVE (11-ECAS-K11)	449 462 080 0	2	
12	1 PRESSURE SENSOR	441 040 015 0	1	
13	2 DISTANCE SENSOR	441 050 011 0	1	
14	1 REMOTE CONTROL UNIT	446 036 116 0	1	
15	1 ECAS-ECU-KIT 6x0 FOR VCS	446 120 011 0	1	
16	1 PROTECTION CAP	446 120 011 0	1	
17	1 LINKAGE	446 120 011 0	1	
18	1 LINE FILTER	432 500 021 0		
19	1 DRAIN VALVE	954 300 001 0		
20	1 RESERVOIR	954 939 001 2		
21	6.0 BAR	463 100 125 0		
22	OPTION	463 100 998 0		
23	OPTION	898 020 319 2		
24	OPTION	433 401 003 0		

List of Parameters Trailer ECAS

ECU Variant: 446 055 066 0

Circuit Diagram No.: 841 801 821 0

Parameter Record No.: 8418018210

Par.	Value	Unit
P 0	= 18	
P 1	= 12	
P 2	= 9	
P 3	= 252	
P 4	= 0	
P 5	= 0	counts
P 6	= 15	counts
P 7	= 0	counts
P 8	= 115	counts
P 9	= 0	counts
P10	= 5	counts
P11	= 6	counts
P12	= 255	counts
P13	= 255	counts
P14	= 20	counts
P15	= 15	k.p.h.
P16	= 8	250ms
P17	= 12	25ms
P18	= 80	250ms
P19	= 0	1/3counts

Par.	Value	Unit
P20	= 10	1/3counts
P21	= 0	1/3counts
P22	= 20	1/3counts
P23	= 0	counts
P24	= 115	counts
P25	= 70	k.p.h.
P26	= 30	k.p.h.
P27	= 240	250ms
P28	= 0	1/16bar
P29	= 0	1/16bar
P30	= 255	1/16bar
P31	= 0	k.p.h.
P32	= 0	5s
P33	= 0	5s
P34	= 0	5s
P35	= 0	k.p.h.
P36	= 0	k.p.h.
P37	= 0	1/16bar
P38	= 0	1/16bar
P39	= 0	counts

Par.	Value	Unit
P40	= 120	10s
P41	= 20	k.p.h.
P42	= 16	1/16bar
P43	= 64	1/16bar
P44	= 15	counts
P45	= 0	1/16bar
P46	= 0	1/16bar
P47	= 0	10s
P48	= 48	15min
P49	= 10	counts
P50	= 100	300ms
P51	= 0	k.p.h.
P52	= 0	counts

System Description:

semitrailer with two height sensors
 no lifting axle control / traction help
 compensating for tyre deflection for more spring travel when laden
 raising/lowering from remote-control unit up to calibrated upper value and mechanical stop at bottom
 automatic driving level from 20 k.p.h.
 3 driving levels selectable from remote-control unit
 DL III > DL I > DL II
 automatically addressing driving level II at Vlimit > 70 k.p.h.
 returning to driving level 1 when speed falls below Vlimit < 30 k.p.h.
 remote-control unit cleared up to 15 k.p.h.
 2 freely programmable memory levels via remote-control unit
 2 seconds control delay while stationary and 60 seconds when in motion
 power supply from WABCO EBS

bellows pressure laden 4.0 bar

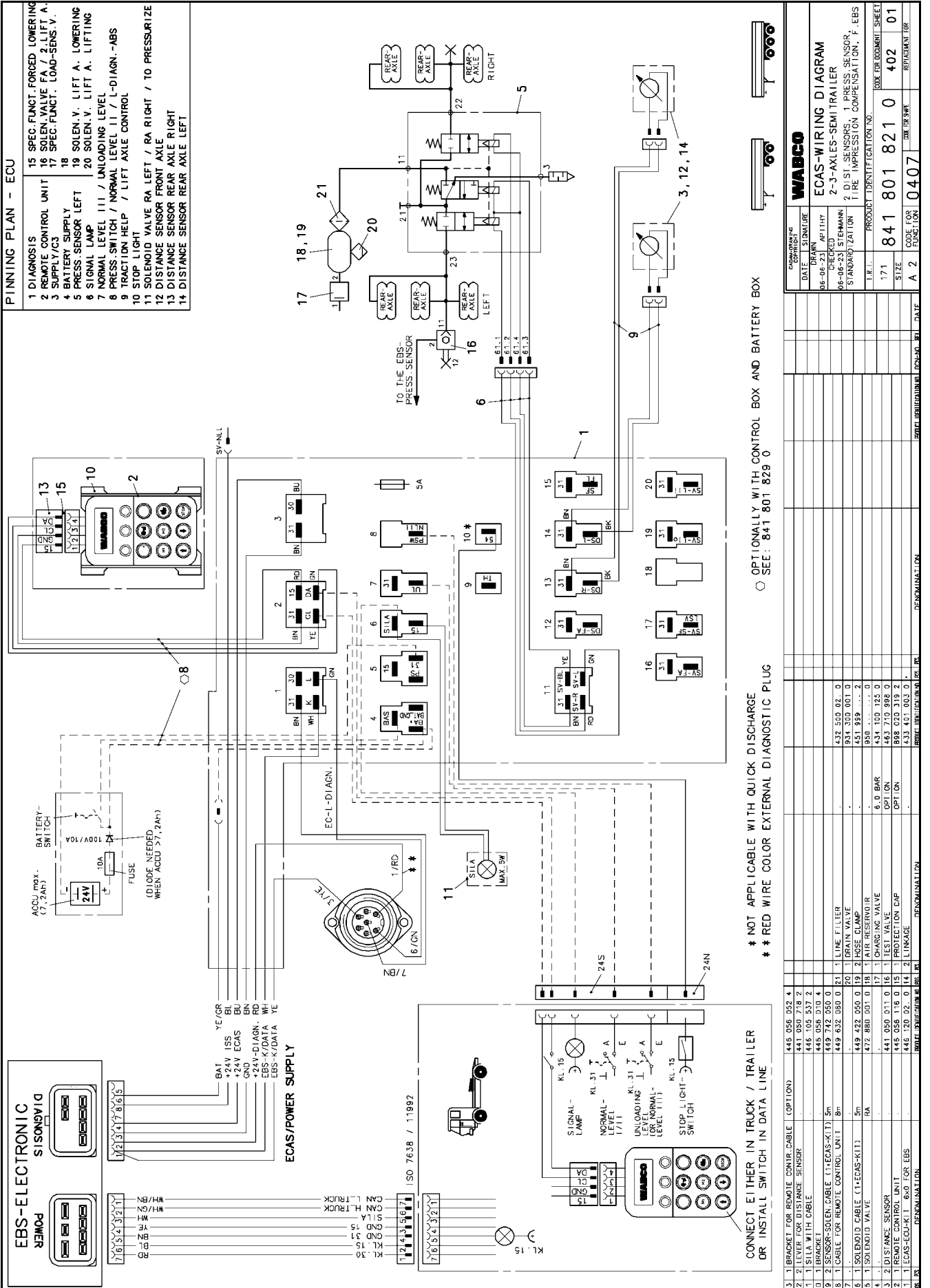

List of Parameters Trailer ECAS

ECU Variant: 446 055 066 0

Circuit Diagram No.: 841 801 822 0

Parameter Record No.: 8418018220

Par.		Value	Unit
P 0	=	18	
P 1	=	24	
P 2	=	13	
P 3	=	92	
P 4	=	5	
P 5	=	0	counts
P 6	=	160	counts
P 7	=	0	counts
P 8	=	115	counts
P 9	=	0	counts
P10	=	5	counts
P11	=	255	counts
P12	=	255	counts
P13	=	255	counts
P14	=	20	counts
P15	=	15	k.p.h.
P16	=	8	250ms
P17	=	12	25ms
P18	=	80	250ms
P19	=	0	1/3counts

Par.		Value	Unit
P20	=	10	1/3counts
P21	=	0	1/3counts
P22	=	20	1/3counts
P23	=	0	counts
P24	=	15	counts
P25	=	255	k.p.h.
P26	=	0	k.p.h.
P27	=	240	250ms
P28	=	64	1/16bar
P29	=	17	1/16bar
P30	=	96	1/16bar
P31	=	20	k.p.h.
P32	=	18	5s
P33	=	255	5s
P34	=	0	5s
P35	=	20	k.p.h.
P36	=	30	k.p.h.
P37	=	83	1/16bar
P38	=	4	1/16bar
P39	=	10	counts

Par.		Value	Unit
P40	=	120	10s
P41	=	20	k.p.h.
P42	=	0	1/16bar
P43	=	0	1/16bar
P44	=	0	counts
P45	=	0	1/16bar
P46	=	0	1/16bar
P47	=	30	10s
P48	=	48	15min
P49	=	10	counts
P50	=	100	300ms
P51	=	20	k.p.h.
P52	=	10	counts

System Description:

semitrailer with one height sensor
 automatic lifting axle control on axle 1 and trailing axle as manoeuvring aid on axle 3
 EC traction help on Axle 1
 lowering to the buffers due to 50% excess weight at a pressure of 6 bar in the supporting bellows
 traction help pressure of 5.2 bar in the supporting bellows
 starting traction help via remote-control unit or rocking switch
 ending traction help by pushing Stop button or holding rocking switch down for more than 5 sec. or Vlimit > 30 k.p.h.
 raising the level by 10 counts when traction help is active
 Starting the manoeuvring aid facility by means of switch / locking button up to EBS ISS ≤ 5 k.p.h.
 unloading level to buffer when switch has been activated (160 counts)
 raising/lowering from remote-control unit up to calibrated upper value and mechanical stop at bottom
 automatic driving level from 20 k.p.h.
 2 driving levels selectable from remote-control unit
 DL II > DL I
 remote-control unit cleared up to 15 k.p.h.
 2 freely programmable memory levels via remote-control unit
 2 seconds control delay while stationary and 60 seconds when in motion
 power supply from WABCO EBS

bellows pressure laden 4.0 bar

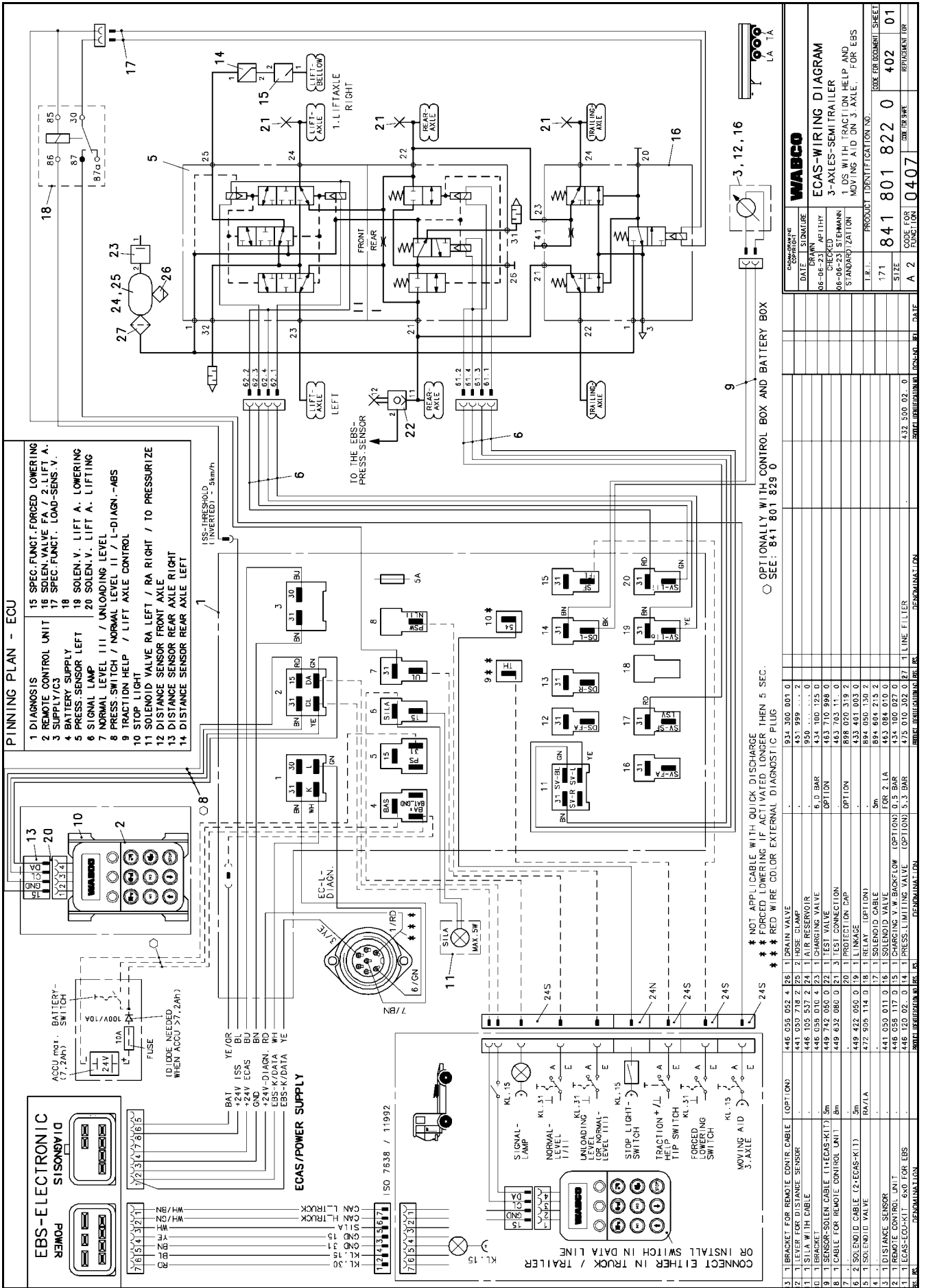

List of Parameters Trailer ECAS

ECU Variant: 446 055 066 0

Circuit Diagram No.: 841 801 823 0

Parameter Record No.: 8418018230

Par.		Value	Unit
P 0	=	18	
P 1	=	24	
P 2	=	77	
P 3	=	92	
P 4	=	5	
P 5	=	0	counts
P 6	=	160	counts
P 7	=	0	counts
P 8	=	115	counts
P 9	=	0	counts
P10	=	5	counts
P11	=	255	counts
P12	=	255	counts
P13	=	255	counts
P14	=	20	counts
P15	=	15	k.p.h.
P16	=	8	250ms
P17	=	12	25ms
P18	=	80	250ms
P19	=	0	1/3counts

Par.		Value	Unit
P20	=	10	1/3counts
P21	=	0	1/3counts
P22	=	20	1/3counts
P23	=	0	counts
P24	=	15	counts
P25	=	255	k.p.h.
P26	=	0	k.p.h.
P27	=	240	250ms
P28	=	64	1/16bar
P29	=	38	1/16bar
P30	=	96	1/16bar
P31	=	20	k.p.h.
P32	=	18	5s
P33	=	255	5s
P34	=	0	5s
P35	=	20	k.p.h.
P36	=	30	k.p.h.
P37	=	83	1/16bar
P38	=	4	1/16bar
P39	=	10	counts

Par.		Value	Unit
P40	=	120	10s
P41	=	20	k.p.h.
P42	=	0	1/16bar
P43	=	0	1/16bar
P44	=	0	counts
P45	=	17	1/16bar
P46	=	25	1/16bar
P47	=	30	10s
P48	=	48	15min
P49	=	10	counts
P50	=	100	300ms
P51	=	20	k.p.h.
P52	=	10	counts

System Description:

- semitrailer with one height sensor
- automatic lifting axle control for two separate lifting axles and EC traction help on Axle 1
- lowering of lifting axle(s) at a pressure of 4 bar in the supporting bellows
- raising the first lifting axle at a pressure of 2.4 bar in the supporting bellows
- raising the second lifting axle at a pressure of 1.6 bar in the supporting bellows
- simultaneously raising both lifting axle up to a pressure of 1.1 bar in the supporting bellows
- lowering to the buffers due to 50% excess weight at a pressure of 6 bar in the supporting bellows
- traction help pressure of 5.2 bar in the supporting bellows
- starting traction help via remote-control unit or rocking switch
- ending traction help by pushing Stop button or holding rocking switch down for more than 5 sec. or Vlimit > 30 k.p.h.
- trailing axle as manoeuvring aid on last axle
- Starting the manoeuvring aid facility by means of switch / locking button up to EBS ISS > 5 k.p.h.
- lifting axle(s) is lowered after ignition OFF
- lifting axle(s) is (are) raised after vehicle was stopped once and subsequently moved at >20 k.p.h. up to 2.4 bar
- raising the level by 10 counts at driving level for improved tyre clearance when lifting axle is raised
- raising the level by 10 counts when traction help is active
- unloading level to buffer when switch has been activated (160 counts)
- raising/lowering from remote-control unit up to calibrated upper value and mechanical stop at bottom
- automatic driving level from 20 k.p.h.
- 2 driving levels selectable from remote-control unit
- DL II > DL I
- remote-control unit cleared up to 15 k.p.h.
- 2 freely programmable memory levels via remote-control unit
- 2 freely programmable memory levels via remote-control unit
- power supply from WABCO EBS

bellows pressure laden 4.0 bar

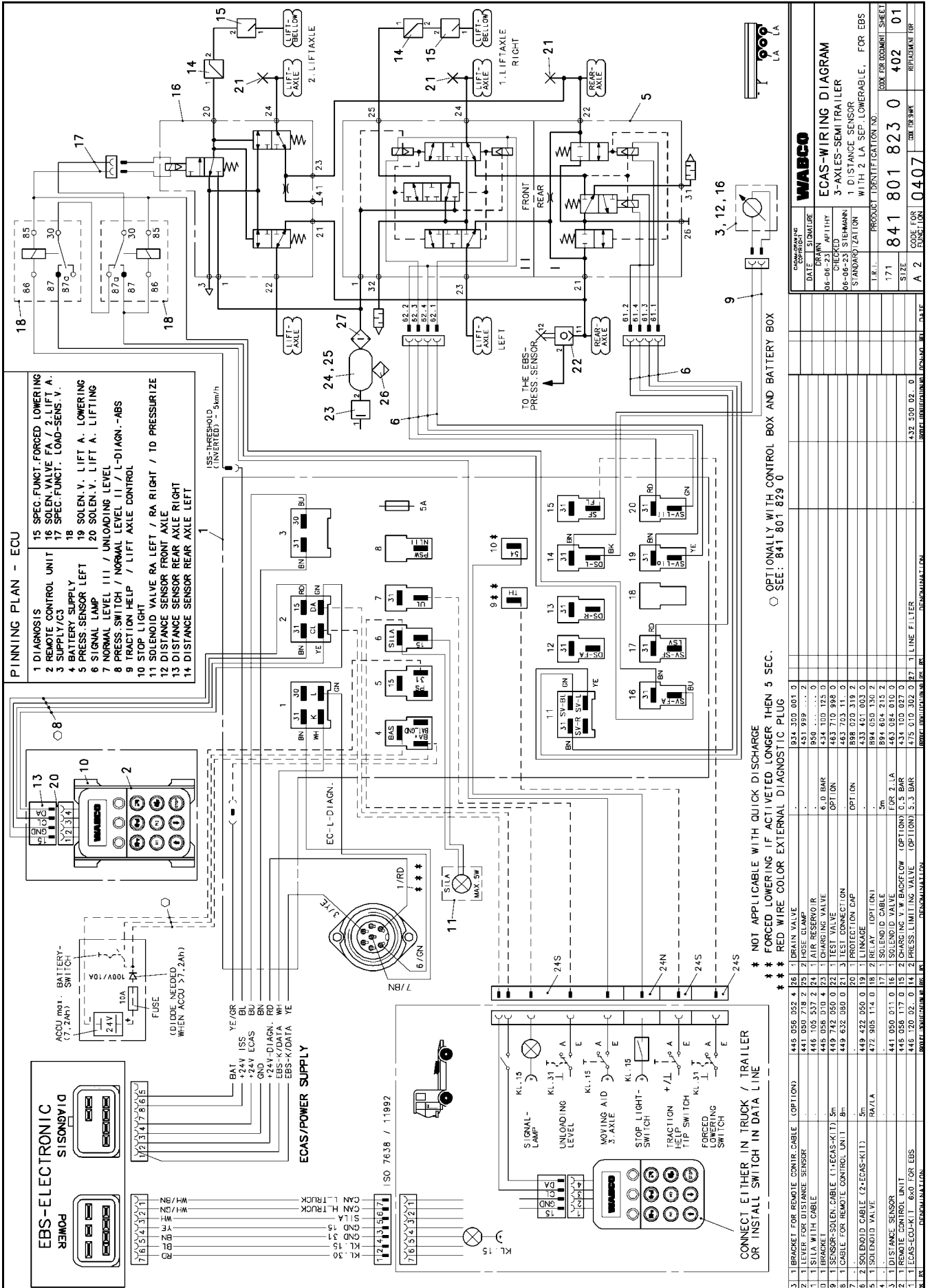

WABCO	
DATE	DRAWN
08-06-23	AP1111
ECAS-WIRING DIAGRAM	
3-AXLES-SEMI TRAILER	
WITH 2 LA SEP. LOWERABLE, FOR EBS	
1 DISTANCE SENSOR	
STANDARD ZATION	
WITH 2 LA SEP. LOWERABLE, FOR EBS	
PRODUCT IDENTIFICATION NO.	
171	
SIZE	CODE FOR IDENTIFICATION SHEET
A 2	841 801 823 0
FOR TRUCK	FOR TRUCK
0407	01

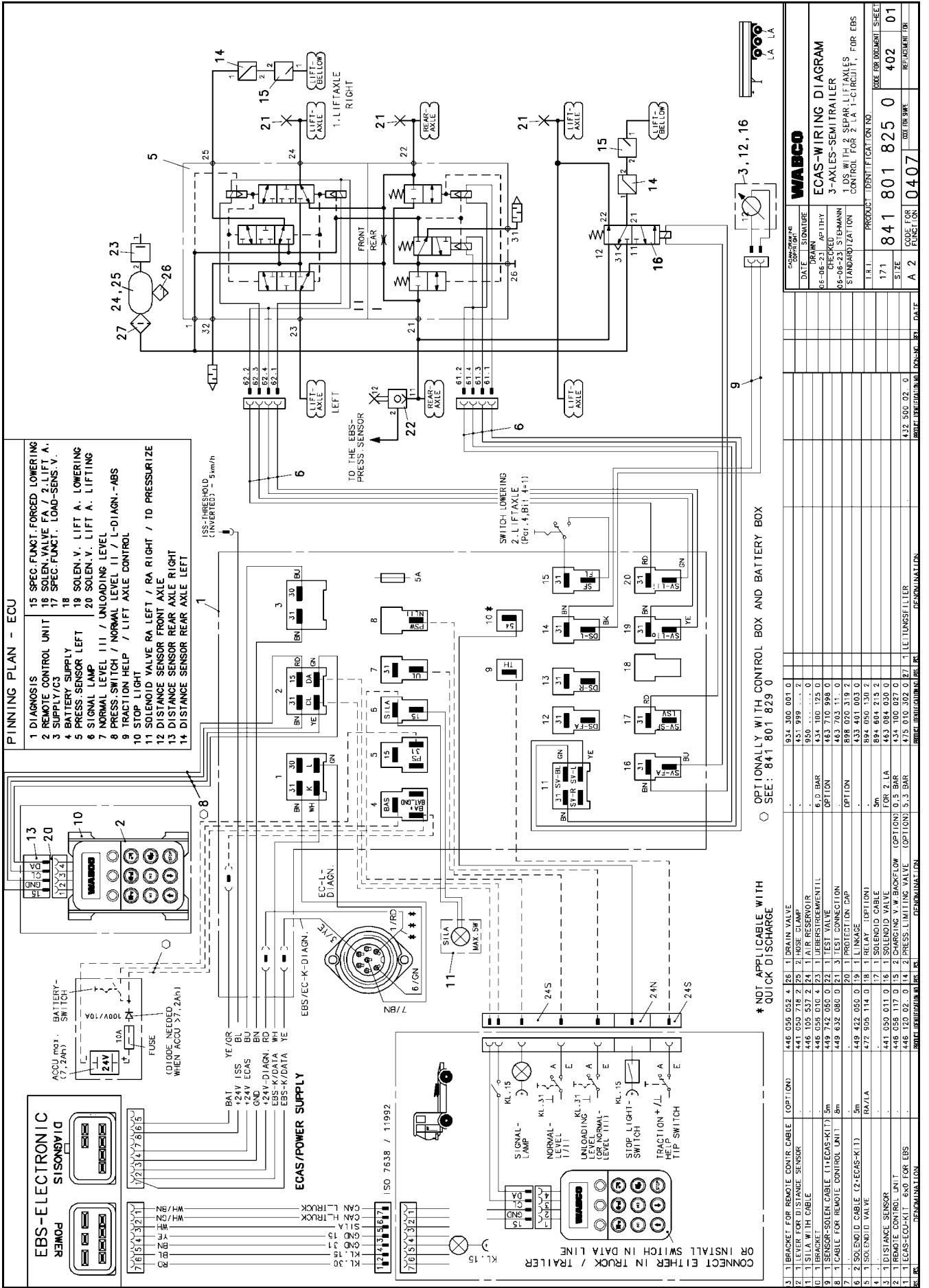

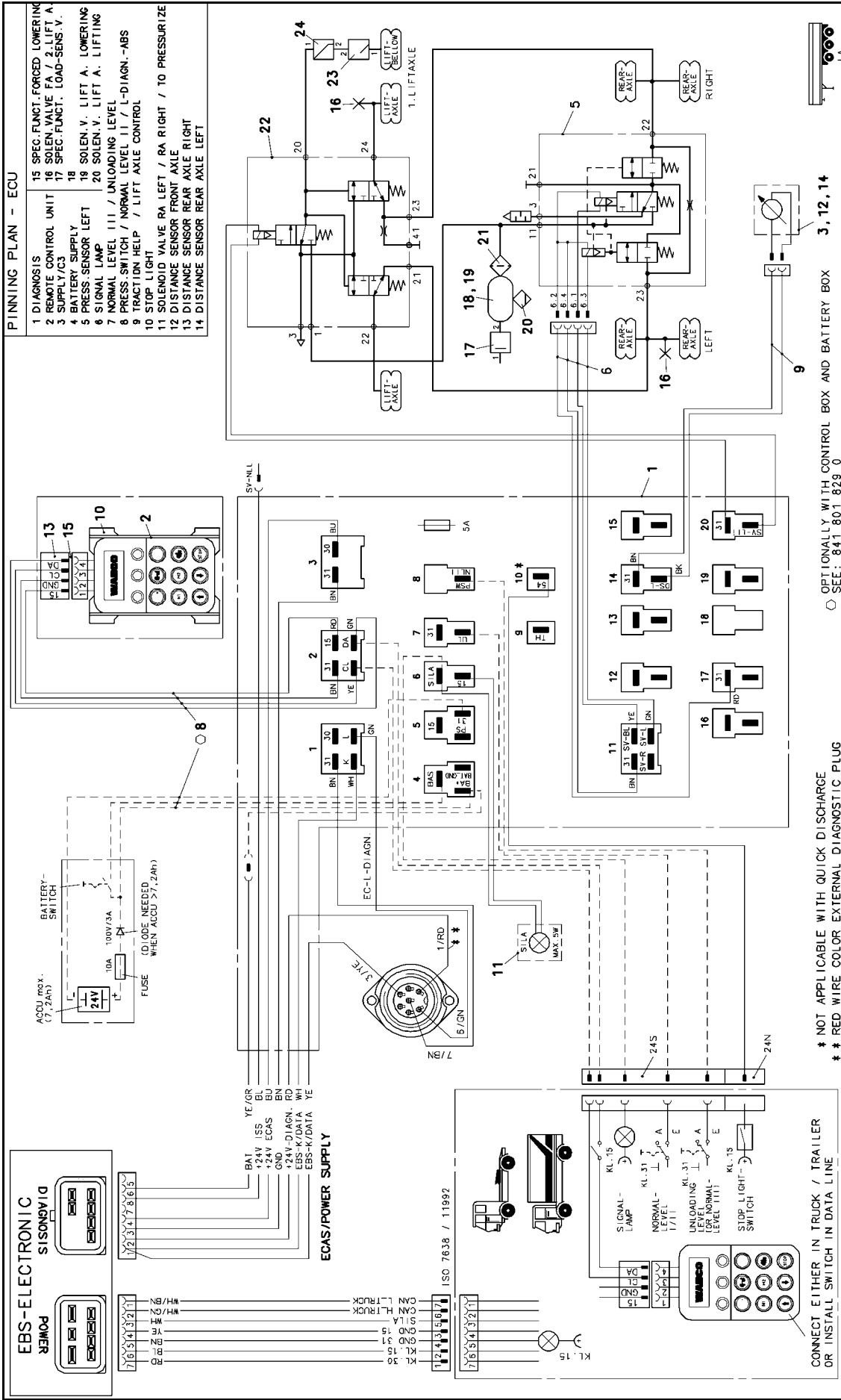

COMPONENT NO.	DESCRIPTION	DATE	REVISION	BY	CHKD.	APP'D.	REVISION	BY	CHKD.	APP'D.
1	LEVER FOR DISTANCE SENSOR	446 055 032 4								
2	1 S/L.A WITH CABLE	441 050 718 2								
3	1 BRACKET	446 105 537 2	24							
4	1 CHARGING V.V.W BACKFLOW	446 058 010 4								
5	1 SOLENOID VALVE	449 742 080 0	23							
6	1 LINE FILTER	449 632 080 0	21							
7	1 DRAIN VALVE	449 652 080 0								
8	1 RESERVOIR	472 658 030 0	18							
9	1 CHARGING VALVE	441 050 011 0	16							
10	1 PROTECT ON CAP	446 058 116 0	15							
11	1 LINKAGE	446 120 02 0	14							

REVISION	DESCRIPTION	DATE
1	INITIAL ISSUE	01.01.00
2	REVISION	01.01.00
3	REVISION	01.01.00
4	REVISION	01.01.00
5	REVISION	01.01.00
6	REVISION	01.01.00
7	REVISION	01.01.00
8	REVISION	01.01.00
9	REVISION	01.01.00
10	REVISION	01.01.00
11	REVISION	01.01.00
12	REVISION	01.01.00
13	REVISION	01.01.00
14	REVISION	01.01.00
15	REVISION	01.01.00
16	REVISION	01.01.00
17	REVISION	01.01.00
18	REVISION	01.01.00
19	REVISION	01.01.00
20	REVISION	01.01.00
21	REVISION	01.01.00
22	REVISION	01.01.00
23	REVISION	01.01.00
24	REVISION	01.01.00

DATE	REVISION	BY	CHKD.	APP'D.
01.01.00	1			
01.01.00	2			
01.01.00	3			
01.01.00	4			
01.01.00	5			
01.01.00	6			
01.01.00	7			
01.01.00	8			
01.01.00	9			
01.01.00	10			
01.01.00	11			
01.01.00	12			
01.01.00	13			
01.01.00	14			
01.01.00	15			
01.01.00	16			
01.01.00	17			
01.01.00	18			
01.01.00	19			
01.01.00	20			
01.01.00	21			
01.01.00	22			
01.01.00	23			
01.01.00	24			

DATE	REVISION	BY	CHKD.	APP'D.
01.01.00	1			
01.01.00	2			
01.01.00	3			
01.01.00	4			
01.01.00	5			
01.01.00	6			
01.01.00	7			
01.01.00	8			
01.01.00	9			
01.01.00	10			
01.01.00	11			
01.01.00	12			
01.01.00	13			
01.01.00	14			
01.01.00	15			
01.01.00	16			
01.01.00	17			
01.01.00	18			
01.01.00	19			
01.01.00	20			
01.01.00	21			
01.01.00	22			
01.01.00	23			
01.01.00	24			

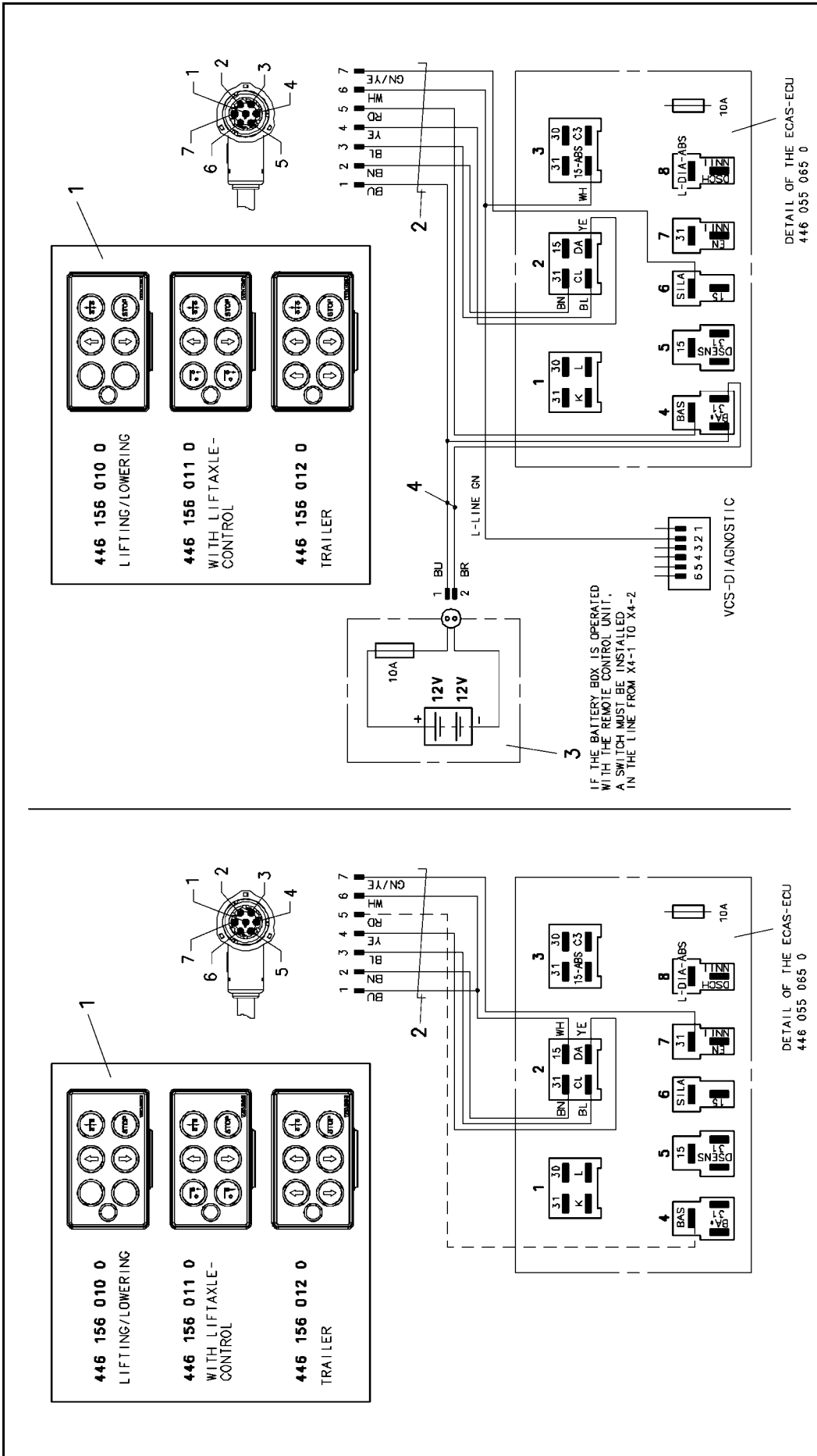

CADW-DRAWING		SIGNATURE		PRODUCT IDENTIFICATION NO.	
DATE	DATE	DATE	DATE	SIZE	DCN-NO. (REF.)
04-09-16	04-09-16	171	841 801 828 0	A 3	088967 A 04-11-10
DRAWN: AP LITHY		CHECKED: STEFANN		CODE FOR FUNCTION	CODE FOR DOCUMENT
STANDARDIZATION		STANDARDIZATION		0307	411 01
T.R.L.		PRODUCT IDENTIFICATION NO.		REPLACEMENT FOR	
		841 801 828 0			
		ECAS-VCS WIRING			
		WITH CONTROL BOX AND BATTERY BOX			
		DETAIL OF THE ECAS-EDU			
		446 055 065 0			
		WABCO			
		446 156 010 0			
		LIFTING/LOWERING			
		446 156 011 0			
		WITH LIFTAXLE-CONTROL			
		446 156 012 0			
		TRAILER			
		10A			
		12V 12V			
		BATTERY BOX			
		L-LINE ON			
		1 BU 2 BR			
		3.1 3.0 K L			
		1			
		3.1 1.5 BN CL DA YE WH			
		2			
		3.1 3.0 1S-ABS CS WH			
		3			
		BAS			
		4			
		1.5 SN			
		5			
		SILA			
		6			
		3.1			
		7			
		L-DIA-ABS			
		8			
		10A			
		VCS-DIAGNOSTIC			
		6.5 4 3 2 1			
		1 2 3 4 5 6 7			
		GN/YE HM Q YE BL BN B			
		1 2 3 4 5 6 7			
		1			
		2			
		3			
		4			
		5			
		6			
		7			
		8			
		9			
		10			
		11			
		12			
		13			
		14			
		15			
		16			
		17			
		18			
		19			
		20			
		21			
		22			
		23			
		24			
		25			
		26			
		27			
		28			
		29			
		30			
		31			
		32			
		33			
		34			
		35			
		36			
		37			
		38			
		39			
		40			
		41			
		42			
		43			
		44			
		45			
		46			
		47			
		48			
		49			
		50			
		51			
		52			
		53			
		54			
		55			
		56			
		57			
		58			
		59			
		60			
		61			
		62			
		63			
		64			
		65			
		66			
		67			
		68			
		69			
		70			
		71			
		72			
		73			
		74			
		75			
		76			
		77			
		78			
		79			
		80			
		81			
		82			
		83			
		84			
		85			
		86			
		87			
		88			
		89			
		90			
		91			
		92			
		93			
		94			
		95			
		96			
		97			
		98			
		99			
		100			

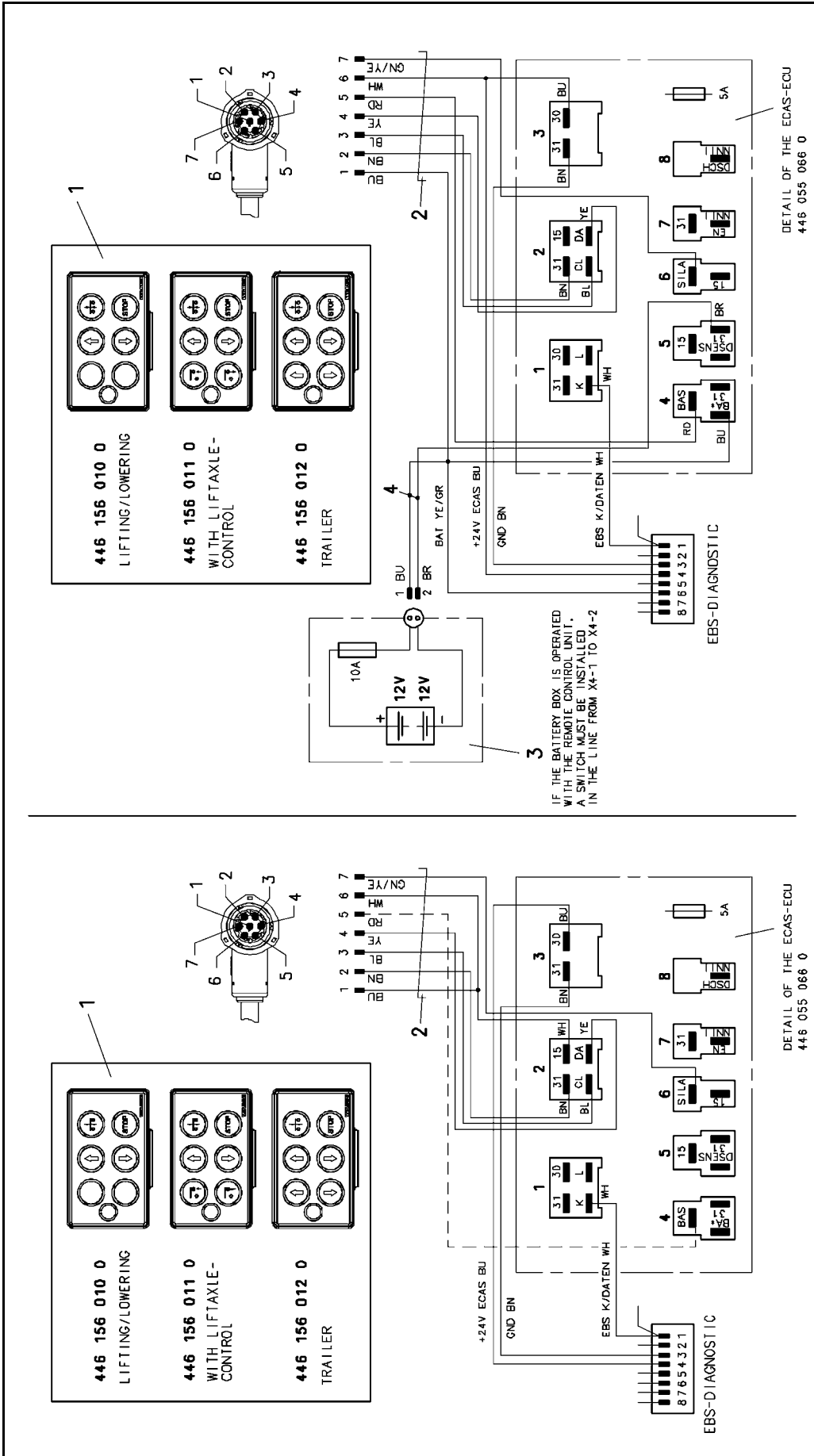

CAD/DRAWING COPYRIGHT		SIGNATURE		WABCO	
DATE		DATE		ECAS-EBS WIRING WITH CONTROL BOX AND BATTERY BOX	
DRAWN 04-09-16		AP I THY		PRODUCT IDENTIFICATION NO.	
CHECKED 04-09-16		STIEHMANN STANDARDIZATION		841 801 829 0	
T.R.I.		SIZE		CODE FOR DOCUMENT SHEET	
171		A 3		411 01	
CODE FOR FUNCTION		CODE FOR SHIP		REPLACEMENT FOR	
0307		0307		0307	
088962 A		04-11-09		DATE	
DENOMINATION		DENOMINATION		DENOMINATION	
4 1 CABLE		449 517 ... 0			
3 1 BATTERY BOX		446 156 094 0			
2 1 CABLE		449 637 ... 0			
*1 1 CONTROL BOX CORRESP. TO VEH. CONFIG.		446 156 0... 0			
RES. RES.		PRODUCT IDENTIFICATION NO.		RES. RES.	

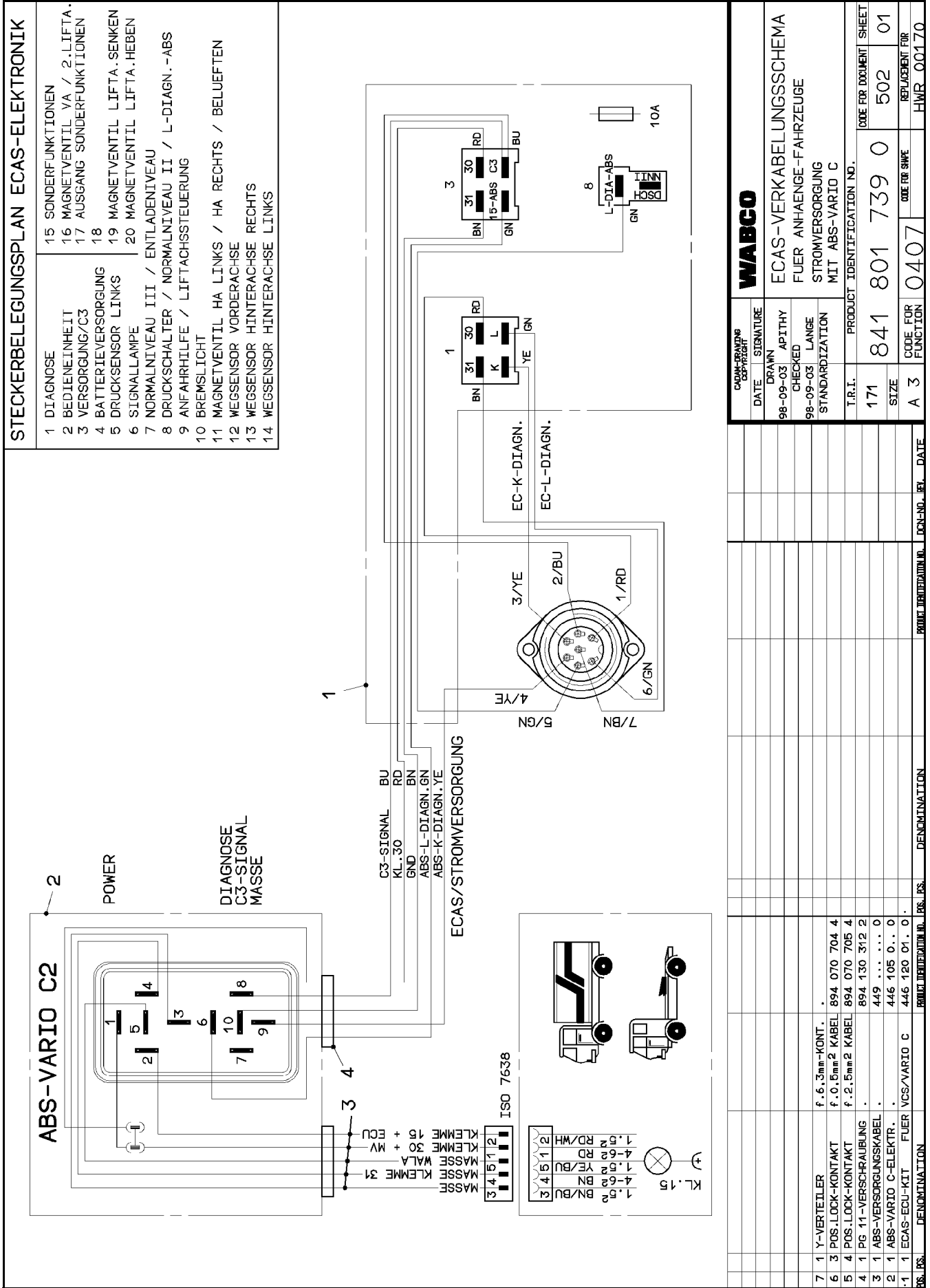

Cable overview

Use prefabricated cables on ECAS for trailer vehicles. These feature moulded plugs. The different types of cables are available in various lengths.

Table 10: Cable overview

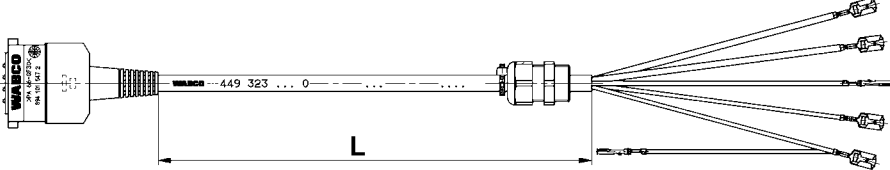
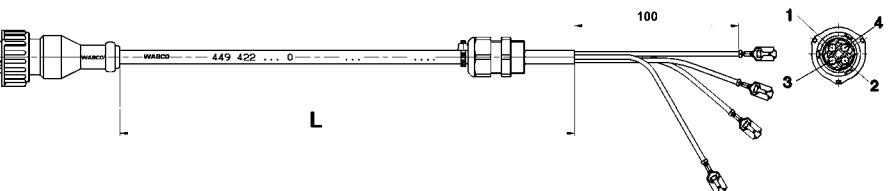
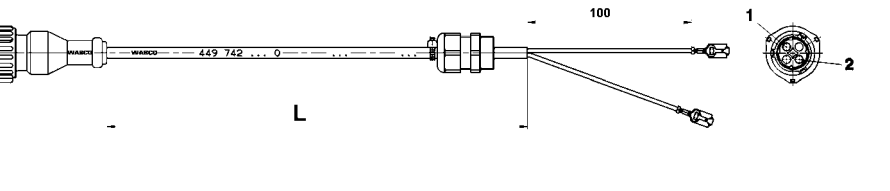
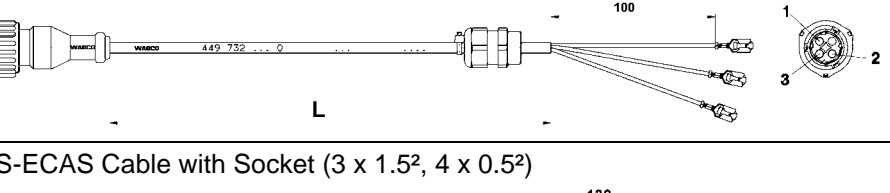
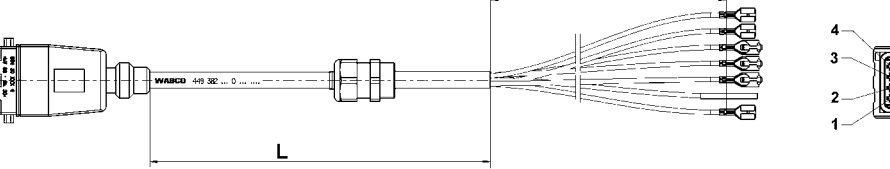
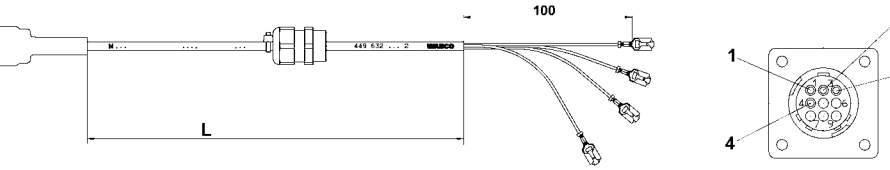
Wire	Part number	Length L (mm)
VCS Supply Cable (2 x 2.5², 4 x 0.5²) 	449 323 010 0 449 323 015 0 449 323 060 0 449 323 ... 0	1,000 1,500 6,000 ...
Solenoid Cable (4 x 1.0²) with DIN Bayonet (DIN 72585-B1-4.1-Sn/K1) 	449 422 010 0 449 422 030 0 449 422 050 0 449 422 060 0 449 422 100 0 449 422 200 0	1,000 3,000 5,000 6,000 10,000 20,000
Height Sensor Cable (2 x 0.75²) with DIN Bayonet (DIN 72585-B1-2.1-Sn/K1) 	449 742 010 0 449 742 030 0 449 742 050 0 449 742 060 0 449 742 100 0 449 742 150 0	1,000 3,000 5,000 6,000 10,000 15,000
Pressure Sensor Cable (3 x 0.5²) with DIN Bayonet (DIN 72585-B1-3.1-Sn/K1) 	449 732 030 0 449 732 060 0 449 732 100 0	3,000 6,000 10,000
EBS-ECAS Cable with Socket (3 x 1.5², 4 x 0.5²) 	449 382 010 0 449 382 015 0 449 382 060 0 449 382 080 0 449 382 090 0	1,000 1,500 6,000 8,000 9,000
Cable Remote Control Unit (4 x 0.5²) 	449 632 015 0 449 632 050 0 449 632 080 0	1,500 5,000 8,000

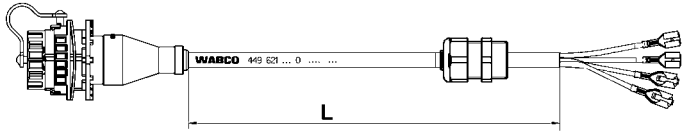
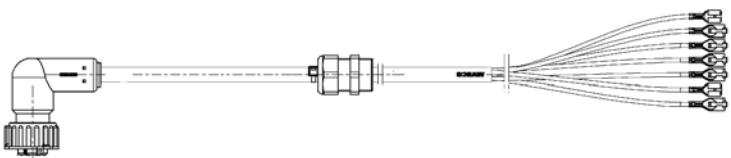
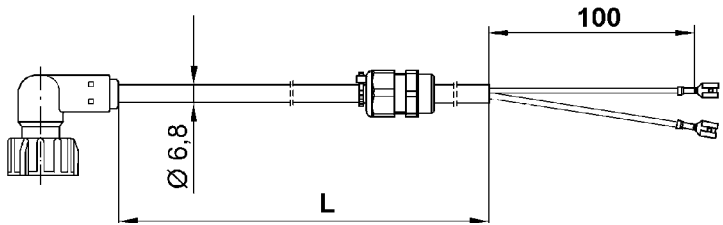
Wire	Part Number	Length L (mm)
<p>Diagnosis Cable (4 x 1.0²)</p> 	<p>449 621 010 0 449 621 060 0 449 621 080 0</p>	<p>1,000 6,000 8,000</p>
<p>Cable for Control Box</p> 	<p>449 637 050 0</p>	<p>5,000</p>
<p>Cable for Battery Box</p> 	<p>449 517 060 0</p>	<p>6,000</p>

Technische Prüfstelle für den Kraftfahrzeugverkehr



Bericht Nr. 60491 Car/My

Ausfertigung

Blatt 1

Gutachten
über eine elektronische Anhängerniveauregelung

1. Allgemeines

Antragsteller : Wabco Westinghouse
Fahrzeuggbremsen
Am Lindener Hafen 21
3000 Hannover

Hersteller : wie Antragsteller
Typbezeichnung : ECAS
Ausführung : nach Schema 841 801 333 0
Verwendung : Sattelanhänger

2. System- und Funktionsbeschreibung

Die Niveauregelung ECAS ist eine elektronisch geregelte Luftfederungsanlage für Kraftfahrzeuge und Anhängerfahrzeuge. Je nach Kombination und Ausführung der Komponenten

- Sensoren
- Elektronik
- Magnetventile
- Luftfederbälge
- Bedieneinheit

sind unterschiedliche Niveau-Regelungs-Anwendungen möglich.

Technische Prüfstelle für den Kraftfahrzeugverkehr



Bericht Nr. 60491 Car/My

Ausfertigung

Blatt 2

Bei dem begutachteten Fahrzeug, Identifizierungsnummer 106 636, Fabrikat Feidbinder, handelt es sich um einen 3-achsigen Sattelanhänger, dessen Niveau über je 3 seitenweise parallel geschaltete Luftfeder-Bälge eingestellt wird. Die Belüftung erfolgt über 3 druckluftgespeiste Magnetventile. Eine Querdrossel sorgt dabei für einen - zeitlich verzögerten - Druckausgleich zwischen linken und rechten Luftfeder-Bälgen.

Zur Niveau-Erfassung dient ein Wegsensor. Die zur Steuerung eingesetzte elektronische Baugruppe arbeitet mit einem Microcomputer, dessen Überwachungsmaßnahmen plausiblen Funktionen und der Fehlererkennung an den angeschlossenen Komponenten dienen.

Für die Regelfunktion erfolgt ein dauernder Vergleich des Weg-Ist-Wertes mit dem gespeicherten Soll-Wert. Bei Abweichungen über ein Toleranzband hinaus werden die Magnetventile angesteuert und durch Be-/Entlüftung das Ist-Niveau dem Soll-Niveau angeglichen.

Kurz vor Erreichen des Soll-Niveaus werden die Magnetventile in Abhängigkeit von der Hubgeschwindigkeit und der Soll-Ist-Differenz gepulst, um ein Überspringen zu vermeiden. Zur Berücksichtigung dynamischer Niveau-Änderungen bei Fahrt wird das Geschwindigkeitssignal aus dem ABS-System abgefragt. Weitere Verbindungen der Steuerelektronik (ECAS-ECU) nach extern erfolgen

- zur Bedieneinheit
 - zur Berücksichtigung der Brems-Funktion
 - über eine Diagnoseschnittstelle.
- Der Einbau erfolgt im ABS-Schutzgehäuse.



Technische Prüfstelle
für den Kraftfahrzeugverkehr

Bericht Nr. 60491 Car/My Ausfertigung Blatt 4

Gegenstand der Prüfungen waren daher insbesondere folgende Aspekte:

- anforderungsgemäße Funktion im ungestörten Betrieb
- Verhalten bei Störungen
- Selbstüberwachung, Fehlererkennbarkeit
- Ausschluß gefährlicher Folgen im Fehlerfall
- Verträglichkeit mit anzusetzenden Umgebungsbedingungen (z. B. Temperatur, Feuchte, Erschütterungen, elektromagnetische Störungen) und ihre Umsetzung im Sicherheitskonzept und der zugehörigen Dokumentation.

Die Definition des "sicheren Zustandes" (Ventilentregung) entspricht in der geprüften Ausführung den in diesem Anwendungsfall zu realisierenden Funktionen. Dies ist insbesondere dadurch begründet, daß der denkbare gefährliche Zustand "Schiefregelung" durch den Druckausgleich über die Querdrossel kurzfristig korrigiert wird.

Unzulässige Rückwirkungen auf das sicherheitstechnisch bedeutsamere ABS-System wird durch den ABS-seitigen kurzschlußfesten Ausgangsbaustein Rechnung getragen.

Die für den Fahrzeugnutzer erforderlichen Informationen werden in einer Kundenspezifikation zusammengefaßt.



Technische Prüfstelle
für den Kraftfahrzeugverkehr

Bericht Nr. 60491 Car/My Ausfertigung Blatt 3

3. Sicherheitsmaßnahmen

Die Selbstüberwachung der Regelelektronik erfolgt hinsichtlich der Speicherintervalle und plausibler Funktion.

Weitere Überwachungsmaßnahmen gelten der Fehlererkennung angeschlossener Komponenten und der Spannungsversorgung. Mit der beim geprüften Fahrzeug vorhandenen optionellen Warnlampe werden erkannte Fehler ständig oder blinkend angezeigt.

4. Prüfumfang und -ergebnisse

Ziel der sicherheitstechnischen Überprüfungen war der Nachweis, daß die Bestimmungen der Straßenverkehrszulassungsordnung (StVZO), insbesondere § 30, erfüllt wird.

Dabei wurde betrachtet, ob

- das Versagen einzelner Komponenten bzw. Bauelemente nicht zu unzulässigen Auswirkungen führt
- die Zuverlässigkeit der Komponenten und ihres Zusammenwirkens so hoch ist, daß keine signifikante Gefährdungserhöhung gegenüber vergleichbaren, bereits zugelassenen rein mechanischen Systemen zu erwarten ist.

Neben eigenen Untersuchungen wurden dazu Herstellerangaben und -prüfungen entsprechend dem Richtlinien-Entwurf zu § 30 StVZO zur "Prüfung von Systemen mit elektronischen Komponenten in Kraftfahrzeugen", Stand 13.09.91, herangezogen.

Technische Prüfstelle
für den Kraftfahrzeugverkehr



Bericht Nr. 60491 Car/My

Auflösung

Blatt 5

Bauteil	Codierung
Elektronik	446055 (884901)
ABV-Gehäuse	446105
Sensor	441050
Ventilblock	472900
Bedieneinheit	446056

5. Zusammenfassung

Die beschriebene ECAS-Niveauregelung ist entsprechend den durchgeführten Prüfungen und der vorgelegten Dokumentation als ausreichend betriebssicher und rückwirkungsfrei einzustufen.

Die sicherheitstechnischen Anforderungen werden in der der Prüfung zugrundegelegten Aufgabenstellung erfüllt.

Hamburg / Lüneburg, den 22.11.1991

Carls

Dipl.-Ing. Carls
Sachverständiger des
Technischen Überwachungs-
Verains Norddeutschland e.V



Meyer

Dipl.-Ing. Meyer
Amtlich anerkannter
Sachverständiger für den
Kraftfahrzeugverkehr



Bericht Nr. 60491 Car/My

Auflösung

Blatt 6

Anlagen

- Kurzbeschreibung des geprüften Fahrzeuges nach Schema 841 801 333 0
- Schema 841 801 333 0
- Auflistung der vorgelegten Unterlagen





Technische Prüfstelle
für den Kraftfahrzeugverkehr

<p>Bericht Nr. 60491 Car/My</p>	<p>Blatt</p>
<p>... Ausfertigung</p>	
<p>Anlage 3 zum Gutachten über eine elektronische Anhängerniveauregelung</p>	
<p>Auflistung der vorgelegten Unterlagen</p>	
<ul style="list-style-type: none"> - Fa. WABCO ECAS Elektronische Niveauregelung für luftgefederte Nutzfahrzeuge und Kraftomnibusse, Informationsbroschüre, Ausgabe Juli 1991 - Fa. WABCO Elektronisch gesteuerte Luftfederung (ECAS) für LKW, Product Specification 431 035 001 0, Rev. D vom 12.12.90 - Fa. WABCO ECAS-Elektronik Product Specification 446 055 020 0 vom 28.05.91 - Fa. WABCO Schreiben an den TÜV Norddeutschland e.V. vom 05.11.91 betr. Beantwortung offener Fragen - Fa. WABCO ECAS Sattelanhänger, Schema 841 801 333 0 und Kurzbeschreibung (Anlage 1 und 2) 	



Bericht Nr. 270392 Rod/My	Anderung	Blatt 1
Gutachten		
über eine elektronisch geregelte Luftfederungsanlage		
1. Allgemeines	Wabco Westinghouse Fahrzeugbremsen Am Lindener Hafen 21 3000 Hannover 91	
Antragsteller:	wie Antragsteller	
Hersteller:	ECAS	
Typbezeichnung:	Schema 841 801 403 0 Index A vom 05.05.92 Schema 841 801 404 0 Index A vom 05.05.92	
Ausführung:		
Verwendung:	1. Sattelanhänger Elektronische Niveauregelung der Hinterachse Optional ALB Funktionen: Heben und Senken Normalniveau-Einstellung Memory-Einstellungen Stop-Funktion	
	2. Sattelanhänger Elektronische Niveauregelung der Hinterachse und 1 Liftachse (1 Drucksensor) Optional ALB Funktionen: Heben und Senken Normalniveau-Einstellung Memory-Einstellungen Stop-Funktion Liftachssteuering mit automa- tischer Absenkung Anfahrhilfe	



Bericht Nr. 270392 Rod/My	Anderung	Blatt 2
3. Deichselanhänger Elektronische Niveauregelung der Hinter- und Vorderachse Optional ALB Funktionen: Heben und Senken Normalniveau-Einstellung Memory-Einstellungen Stop-Funktion		
2. System- und Funktionsbeschreibung	Die Niveauregelung ECAS ist eine elektronisch geregelte Luftfederungsanlage für Kraftfahrzeuge und Anhängerfahrzeuge. Je nach Kombination und Ausführung der Komponenten	
	<ul style="list-style-type: none"> - Sensoren - Elektronik/Software - Magnetventile - Luftfederbälge - Bedieneinheit 	
	sind unterschiedliche Niveauregelungsanwendungen möglich:	
	<ul style="list-style-type: none"> - konstante Niveaulage ohne manuelle Nachregelung - automatische Anfahrhilferegelung - Steuerung der Liftachse. 	
	Wegsensoren erfassen laufend die Höhenlage des Fahrzeugs und geben entsprechende Informationen an die Elektronik. Erkennt die Elektronik nach Auswertung der Signale eine Abweichung vom Sollniveau, wird über die entsprechenden Magnetventile nachgeregelt.	
	Kurz vor Erreichen des Sollniveaus werden die Magnetventile gepulst, um ein Überschwingen zu vermeiden.	
	Der Bediener kann über eine Fernbedienung - unterhalb einer parametrierbaren Geschwindigkeitsschwelle - das Sollniveau verändern.	



Technische Prüfstelle für den Kraftfahrzeugverkehr



Bericht Nr. 270392 Rod/My

Ausfertigung

Blatt 3

Über einen Taster kann die Liftachse gehoben werden. Dabei wacht die Elektronik darüber, daß die zulässige(n) Achslast(en) der Hinterachse nicht überschritten wird (werden).

Ebenfalls über diesen Taster kann diese Achse wieder abgesenkt werden. Diese Steuerung ist nur wirksam bis zu einer wählbaren maximalen Geschwindigkeit.

Die Liftachse wird automatisch abgesenkt, wenn durch die Beladung die zulässige Achslast überschritten wird. Hierzu ist es erforderlich, daß ECAS eingeschaltet ist.

Die automatische Steuerung ist nur während des Stillstandes möglich. Damit wird ein ungewolltes Schalten der Magnetventile aufgrund dynamischer Druckänderung während der Fahrt unterbunden.

Durch Betätigung eines Tasters ohne Raststellung im Armaturenbrett kann eine Anfahrhilfe eingeleitet werden. Dabei erfolgt eine automatische Entlastung der Liftachse, bis die zulässige Achslast der tragenden Achse(n) erreicht ist.

Nach Ablauf von maximal 90 Sekunden wird die Achslastverlagerung automatisch wieder rückgängig gemacht.

Eine Wiederholung dieses Vorgangs ist frühestens nach 50 sec. möglich.

Die ECAS-Elektronik besitzt eine Diagnoseschnittstelle.

Der Einbau der Elektronik erfolgt in einem Schutzgehäuse.

Das ECAS-System muß in Verbindung mit einem ABV und einem Druckluftbehälter für die Luftfederanlage betrieben werden. Des weiteren ist für den Betrieb ein C3-(Geschwindigkeits-) Signal erforderlich.



Technische Prüfstelle für den Kraftfahrzeugverkehr



Bericht Nr. 270392 Rod/My

Ausfertigung

Blatt 4

3. Prüfumfang und -ergebnisse

Ziel der sicherheitstechnischen Überprüfung war der Nachweis, daß die Bestimmungen der Straßenverkehrs-Zulassungs-Ordnung (StvZO), insbesondere §§ 30 und 34 erfüllt werden.

Dabei wurde betrachtet, ob

- das Versagen einzelner Komponenten bzw. Bauelemente nicht zu unzulässigen Auswirkungen führt
- die Zuverlässigkeit der Komponenten und ihres Zusammenwirkens so hoch ist, daß keine signifikante Gefährdungserhöhung gegenüber vergleichbaren, bereits zugelassenen rein mechanischen Systemen zu erwarten ist.

Neben eigenen Untersuchungen wurden dazu Herstellerangaben und -prüfungen entsprechend dem Richtlinien-Entwurf zu § 30 StvZO zur 'Prüfung von Systemen mit elektronischen Komponenten in Kraftfahrzeugen', Stand 23.01.92, herangezogen. Gegenstand der Prüfungen waren daher insbesondere folgende Aspekte:

- Anforderungsgemäße Funktion im ungestörten Betrieb
- Verhalten bei Störungen
- Selbstüberwachung
- Fehlererkennbarkeit
- Ausschluß gefährlicher Folgen im Fehlerfall
- Verträglichkeit mit anzusetzenden Umgebungsbedingungen (z.B. Temperatur, Feuchte, Erschütterungen, elektromagnetische Verträglichkeit)

und ihre Umsetzung im Sicherheitskonzept und der zugehörigen Dokumentation.





Technische Prüfstelle für den Kraftfahrzeugverkehr

Bericht Nr. 270392 Rod/My Ausfertigung Blatt 6

Das Prüfergebnis zeigt, daß aufgrund einer integrierten Überwachung der Peripherie eine Vielzahl möglicher Fehler im Gesamtsystem erkannt wird und eine entsprechende Reaktion bzw. Warnanzeige erfolgt.

Die Selbstüberwachung der Regelelektronik erfolgt hinsichtlich der Speicherinhalte und plausibler Funktion.

Weitere Überwachungsmaßnahmen gelten der Fehlererkennung angeschlossener Komponenten und der Spannungsversorgung.

Erkannte Fehler werden durch eine grün blinkende Warnlampe angezeigt.

Des Weiteren wurden probabilistische Berechnungen angestellt. Danach trägt die Ausfallwahrscheinlichkeit der ECU nach Untersuchungen der Fa. WABCO nur unwesentlich zur Gesamtausfallwahrscheinlichkeit einer Luftfederungsanlage bei.

Die Wahrscheinlichkeit eines Ausfalls bei einem nicht spezifikationsgerechten Verhalten der Elektronik ist daher als gering anzusehen.

5. Bauteilangaben

Bauteilangaben siehe Anlagen 1 bis 4.



Technische Prüfstelle für den Kraftfahrzeugverkehr

Bericht Nr. 270392 Rod/My Ausfertigung Blatt 5

5. Zusammenfassung
Die beschriebene ECAS-Niveauregelung ist entsprechend der durchgeführten Prüfungen und der vorgelegten Dokumentation als ausreichend sicher und rückwirkungsfrei einzustufen. Die sicherheitstechnischen Anforderungen wurden in der der Prüfung zugrunde gelegten Aufgabenstellung erfüllt.

Hinweise:

Bei der Parametrierung sind die jeweils geltenden gesetzlichen Vorschriften zu berücksichtigen.

Die für den Fahrzeugnutzer erforderlichen Informationen sind in einer Bedienungsanleitung zusammenzufassen.

Hamburg/Lüneburg, den 22.05.1992

Rode
Dipl.-Ing. Rode



Meyer
Dipl.-Ing. Meyer

Amtlich anerkannter Sachverständiger des Technischen Überwachungsvereins Norddeutschland e.V.

Anlagen

1. Kurzbeschreibung zu Schema 841 801 403 0 vom 29.04.92
2. Schema 841 801 403 0 Index A vom 05.05.92
3. Kurzbeschreibung zu Schema 841 801 404 0 vom 29.04.92
4. Schema 841 801 404 0 Index A vom 05.05.92
5. Auflistung Prüferunterlagen/Schriftverkehr

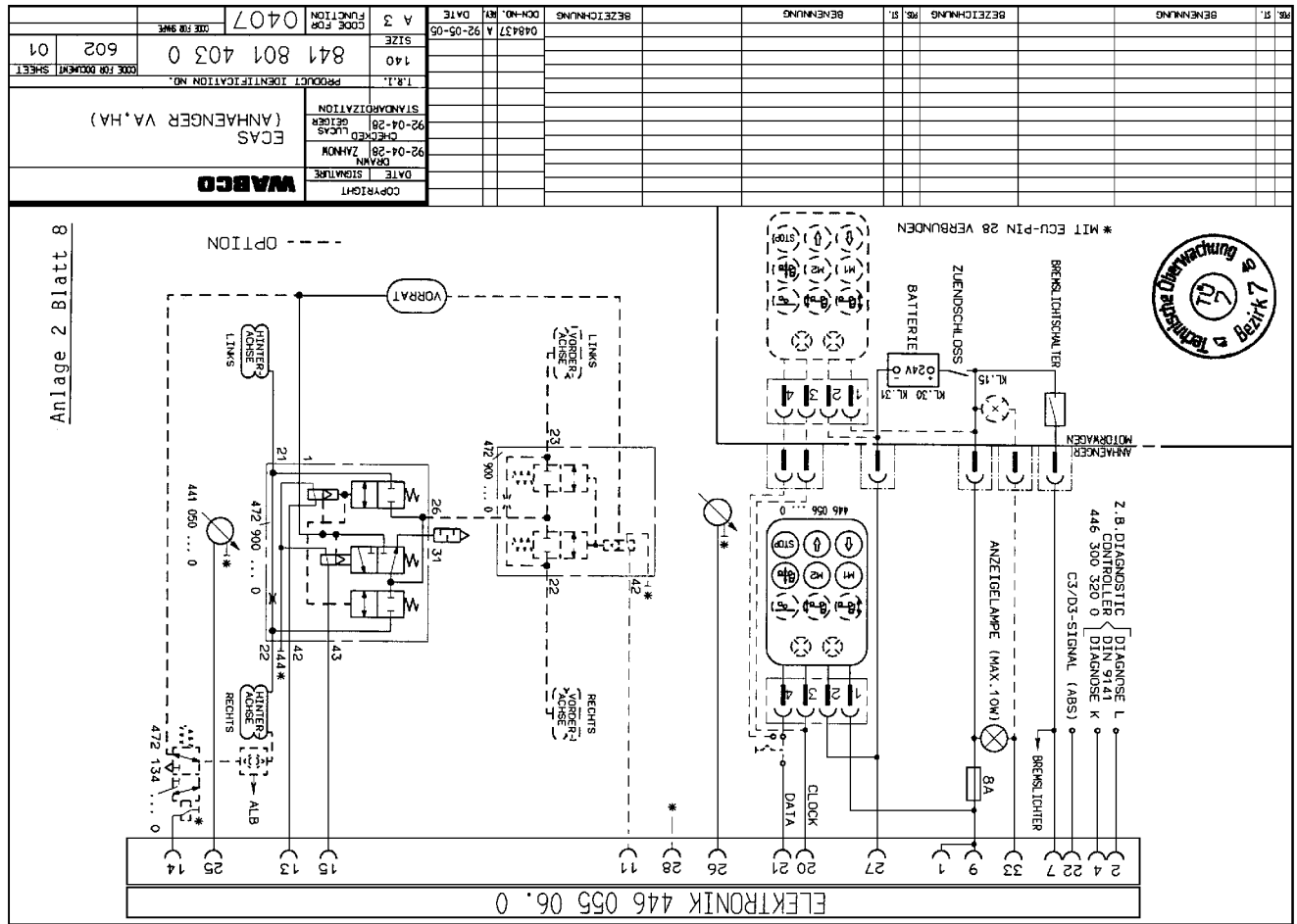

Anlage 2 Blatt 8

Anlage 1 Blatt 7

WABCO

WABCO Westinghouse
Fahrzeugbremsen
Ein Unternehmen der WABCO
Ein Unternehmen der WABCO

HANNOVER, 29.04.92

KURZBESCHREIBUNG NACH SCHEMA 841 801 403 0

- SATTELANHÄNGER, DEICHELANHÄNGER
 - ECU 446 055 06. 0
 - ABV-GEHÄUSE (446 105 ... 0)
 - QUERDROSSEL FÜR DRUCKAUSGLEICH LINKS, RECHTS
 - 1 WEGSENSOR-REGELUNG PRO AXSE (441 050 ... 0)
 - MAGNETVENTIL, HA, BESTEHEND AUS: (472 900 ... 0)
 - 1 X 3/2-WEGEVENTIL FÜR BE- UND ENTLÜFTUNG
 - 2 X 2/2-WEGEVENTIL, PARALLEL GESCHALTET
 - MAGNETVENTIL, VA (OPTION), BESTEHEND AUS: (472 900 ... 0)
 - 2 X 2/2-WEGEVENTIL, PARALLEL GESCHALTET
 - SPANNUNGSVERSORGUNG KL. 15, KL. 31
 - BEDIENEINHEIT (446 056 ... 0)
- FUNKTION: HEBEN - SENKEN
NORMALNIVEAU-EINSTELLUNG
2 X MEMORY-EINSTELLUNG
STOPFUNKTION
VORDERACHSE - HINTERACHSE (OPTION)
- WARNANZEIGE AM AUFBAU
 - GESCHWINDIGKEITSERKENNUNG (C3-SIGNAL V.D. ABS-ECU)
 - SONSTIGE ECU-EIN- UND AUSGÄNGE
 - BREMSLICHTSCHALTER
 - DIAGNOSE NACH ISO 9141



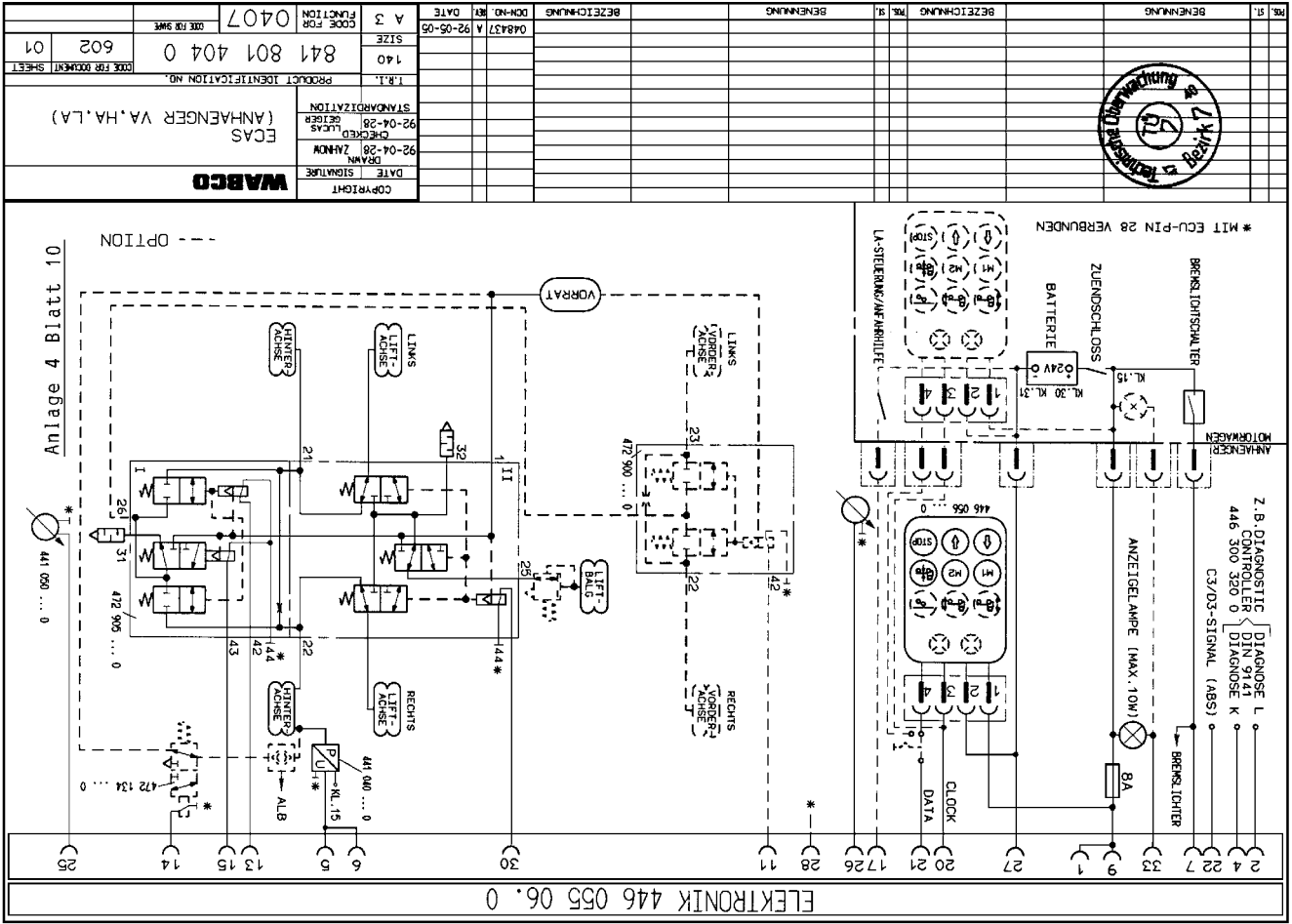

Anlage 3 Blatt 9

WABCO
WABCO Westinghouse
Fahrzeugbremsen
WABCO Standard Contact der
HANNOVER, 29.04.92

KURZBESCHREIBUNG NACH SCHEMA 841_801_404_0

- SATTELANHÄNGER, DEICHELANHÄNGER, MIT EINER LIFTACHSE
 - ECU 446 056 0
 - ABV-GEHÄUSE (446 105 ... 0)
- QUERDROSSEL FÜR DRUCKAUSGLEICH LINKS, RECHTS
- 1 WEGSENSOR-REGELUNG PRO ÄCHSE, LIFTACHSE NICHT SENZERT (441 050 ... 0)
- 1 DRUCKSENSOR FÜR LIFTACHSFUNKTION (441 040 ... 0)
- MAGNETVENTIL HA, LA, BESTEHEND AUS: (472 905 ... 0)
 - 1 x 3/2-WEGEVENTIL FÜR BE- UND ENTLÜFTUNG
 - 2 x 2/2-WEGEVENTIL, PARALLEL GESCHALTET, FÜR HINTERACHSE
 - 3 x 3/3-WEGEVENTIL, PARALLEL GESCHALTET, FÜR LIFTACHSE
- MAGNETVENTIL, VA (OPTION), BESTEHEND AUS: (472 900 ... 0)
 - 2 x 2/2-WEGEVENTIL, PARALLEL GESCHALTET
- SPANNUNGSVERSORGUNG KL. 15, KL. 31
- BEDIENEINHEIT (446 056 ... 0)

FUNKTION: HEBEN - SENKEN
NORMALNIVEAU-EINSTELLUNG
2 x MEMORY-EINSTELLUNG
STORFUNKTION
VORDERACHSE - HINTERACHSE (OPTION)

- WARNANZEIGE AM AUFBAU
- GESCHWINDIGKEITSERKENNUNG (C3-SIGNAL V. D. ABS-ECU)
- SONSTIGE ECU-EIN- UND AUSGÄNGE
 - BREMSLICHTSCHALTER
 - DIAGNOSE NACH ISO 9141



Technische Prüfstelle für den Kraftfahrzeugverkehr

Technische Prüfstelle für den Kraftfahrzeugverkehr



Bericht Nr. 270392 Rod/My	Ausfertigung	Blatt 12
<p>Anlage 5 (Blatt 2 v 2) zum Gutachten über eine elektronisch geregelte Luftfederanlage</p> <ul style="list-style-type: none"> - TÜV Norddeutschland e.V. Telefax vom 01.04.92 - Fa. WABCO Telefax vom 08.04.92 (Beantwortung des Telefax des TÜV Nordd. vom 01.04.92) - Fa. WABCO Schreiben vom 15.04.92 (Beantwortung telefonisch gestellter Fragen des TÜV Nordd.) - TÜV Norddeutschland e.V. Telefax vom 24.04.92 - Fa. WABCO Schreiben vom 28.04.92 (Ausfallwahrscheinlichkeit, Betriebsbewährung der Software) - TÜV Norddeutschland e.V. Telefax vom 04.05.92 - Fa. WABCO Schreiben vom 04.05.92 (Beantwortung des Telefax des TÜV Nordd. vom 04.04.92) 		

Bericht Nr. 270392 Rod/My	Ausfertigung	Blatt 11
<p>Anlage 5 (Blatt 1 v 2) zum Gutachten über eine elektronisch geregelte Luftfederanlage</p> <ul style="list-style-type: none"> - Fa. WABCO Schema ECAS (Anhänger VA,HA) 841 801 403 0 Index A vom 05.05.92 - Fa. WABCO Kurzbeschreibung nach Schema 841 801 403 0 vom 29.04.92 - Fa. WABCO Schema ECAS (Anhänger VA,HA,LA) 841 801 404 0 Index A vom 05.05.92 - Fa. WABCO Kurzbeschreibung nach Schema 841 801 404 0 vom 29.04.92 - Fa. WABCO Fehlererkennung Elektronik 446 055 06. 0 vom 29.04.92 - Fa. WABCO Technische Daten der Ein- und Ausgänge der ECAS-Anhänger- elektronik mit Liftachssteuerung vom 03.04.92 - Fa. WABCO Product Specification 431 035 001 0 vom 03.05.91 - Fa. WABCO Product Specification 446 055 020 0 vom 28.05.91 - Fa. WABCO ECAS-Parameterliste 884 902 364 0 vom 27.03.92 - Fa. WABCO Beschreibung der Lift-/Schleppachssteuerung im Anhänger mit ECAS vom 27.03.92 		





Technischer Überwachungs-Verein Nord e. V.

Technische Prüfstelle für den Kraftfahrzeugverkehr	Bericht-Nr.: 060294	Blatt: 2 von: 11
---	---------------------	---------------------

3. System- und Funktionsbeschreibung

1. zu 2.1 : wie im Prüfbericht 270392 beschrieben.
2. zu 2.2 : Die 2-Punkt-Regelung wird mit 2 Wegsensoren realisiert. Bei einseitigen Lastverhältnissen wird damit eine Schiefelage des Fahrzeugaufbaus vermieden (Schema 841 800 024 0).
- Zusätzlich ermöglicht die Schaltung des Elektronik nach Schema 841 800 023 0 die Links-/Rechts-Regelung. Damit ist im Stand auf geneigtem Untergrund mit Hilfe der Bedieneinheit ein horizontales Ausrichten des Fahrzeugaufbaus möglich.

4. Prüfungsumfang und Ergebnisse

1. zu 2.2 : Im Rahmen des Nachtragsbegutachtung wurden folgende praktische Untersuchungen durchgeführt:
- Einfluß unterschiedlicher Beladung,
 - fahrdynamische Auswirkungen, auch mit Störfall-Simulation,
 - Funktionsprüfung der Links/Rechts-Regelung.
2. Zu 2.1 und 2.2: wie im Prüfbericht 279392 dargestellt.
3. zu 2.3 : Es wurde überprüft,
- ob die elektrische Ausrüstung der Niveauregelung hinsichtlich Eignung und Bemessung den Anforderungen der GGVS/ADR-Vorschriften genügt,
 - ob die allgemeinen Anforderungen für das Errichten elektrischer Anlagen in explosionsgefährdeten Bereichen nach einschlägigen technischen Regeln, insbesondere der DIN VDE 0165, eingehalten werden,



Technischer Überwachungs-Verein Nord e. V.

Technische Prüfstelle für den Kraftfahrzeugverkehr	Bericht-Nr.: 060294	Blatt: 1 von: 11
---	---------------------	---------------------

Nachtragsgutachten
zum Prüfbericht 270392 Rod/My vom 22.05.1992
über eine elektronisch geregelte Luffederungsanlage

1. Allgemeines

Antragsteller: Wabco Westinghouse
Fahrzeugbremsen
Am Lindener Hafen 21
30453 Hannover

Hersteller: wie Antragsteller

Typbezeichnung: ECAS

2. Inhalt des Nachtrags

1. Aktualisierung des Schemas für Sattelanhänger mit Liftachse 841 801 404 0 des Prüfberichtes 270392 mit Schema 841 800 769.
2. Ergänzung des Systems mit den Varianten
 - 2-Punkt-Regelung (Schema 841 800 024 0)
 - 2-Punkt-Regelung und Links-/Rechts-Regelung (Schema 841 800 023 0)
3. Systemüberprüfung auf Einhaltung der GGVS/ADR-Vorschriften, Anhang B 2 "Vorschriften für die elektrische Ausrüstung".

Technischer Überwachungs-Verein Nord e. V.

Technische Prüfstelle für den Kraftfahrzeugverkehr	Bericht Nr.: 060294	Blatt: 3 von 11
---	---------------------	--------------------

- welche Wahrscheinlichkeit des Auftretens gefährlicher explosionsfähiger Atmosphäre besteht,
- ob die speziellen Anforderungen der DIN VDE 0165 entsprechend der zugrunde gelegten Auftretenswahrscheinlichkeit erfüllt werden.

Gegenstand der Prüfung waren dabei insbesondere folgende Aspekte:

- Auswahl der Betriebsmittel
- Vermeidung von Zündgefahren
- Eignung der Kabel und Leitungen
- Eignung der Verbindungselemente

Als Grundlage für die Beurteilung des Umfanges der zu stellenden Anforderungen wurde eine Auftretenswahrscheinlichkeit gefährlicher explosionsfähiger Atmosphäre gemäß Zone 2 gewählt. Die Zone 2 gemäß DIN VDE 0165 umfaßt Bereiche, in denen damit zu rechnen ist, daß gefährliche explosionsfähige Atmosphäre nur selten und auch nur kurzzeitig auftritt.

Es wurde festgestellt, daß die in Anlage 7 aufgelisteten Betriebsmittel der ECAS-Niveauregelung für den Einsatz geeignet und ausreichend bemessen sind.

Die allgemeinen Anforderungen an die Auswahl der Betriebsmittel gemäß DIN VDE 0165 sind erfüllt. Die speziellen elektrischen Anforderungen für Betriebsmittel in Zone 2 sind ebenfalls ausreichend erfüllt, so daß keine Baumuster-Prüfbescheinigung für explosionsgeschützte Betriebsmittel mit Angabe der Zündschutzart erforderlich ist.

Die GGVs/ADR-Vorschriften, Anhang B.2 werden erfüllt.

Technischer Überwachungs-Verein Nord e. V.

Technische Prüfstelle für den Kraftfahrzeugverkehr	Bericht Nr.: 060294	Blatt: 4 von 11
---	---------------------	--------------------

5. Zusammenfassung

Die in diesem Nachtrag beschriebene ECAS-Niveauregelung ist entsprechend den durchgeführten Prüfungen und der vorgelegten Dokumentation als ausreichend sicher und rückwirkungsfrei einzustufen. Die sicherheitstechnischen Anforderungen wurden in der Prüfung zugrunde gelegten Aufgabenstellung erfüllt.

Hinweise für den amtlich anerkannten Sachverständigen zur GGVs/ADR-Prüfung nach Anhang B.2:

- Die Bauteile und elektrischen Leitungen des ECAS-Systems müssen gegen mechanische Beschädigungen und Erwärmung ausreichend geschützt am Fahrzeug angeordnet sein.
- Die Bauteile und elektrischen Leitungen dürfen nicht im Armaturenschrank des Tankfahrzeuges angebracht sein, da dieser gemäß TRBF 111 als Zone 1 eingestuft ist und deshalb Ex-Schutz-Ausrüstung erfordert.

Hamburg/Lüneburg, den 14.06.1994

A. Schramm
Dipl. Ing. Schramm

 Bereich Überwachung
 TU Nord
 Bezirk 7

Sachverständiger des
Technischen Überwachungs-
Vereins Nord e.V.

Dipl. Ing. Meyer
Dipl. Ing. Meyer

Amtlich anerkannter Sach-
verständiger für den Kraft-
fahrzeugverkehr.

Ing. Machens
Dipl. Ing. Machens

Technische Prüfstelle
für den Kraftfahrzeug-
verkehr.
Der Leiter

Anlagen

1. Kurzbeschreibung zu Schema 840 800 769 0
2. Schema 841 800 769 0
3. Kurzbeschreibung zu Schema 841 800 024 0
4. Schema 841 800 024 0
5. Kurzbeschreibung zu Schema 841 800 023 0
6. Schema 841 800 023 0
7. Bauteilangaben

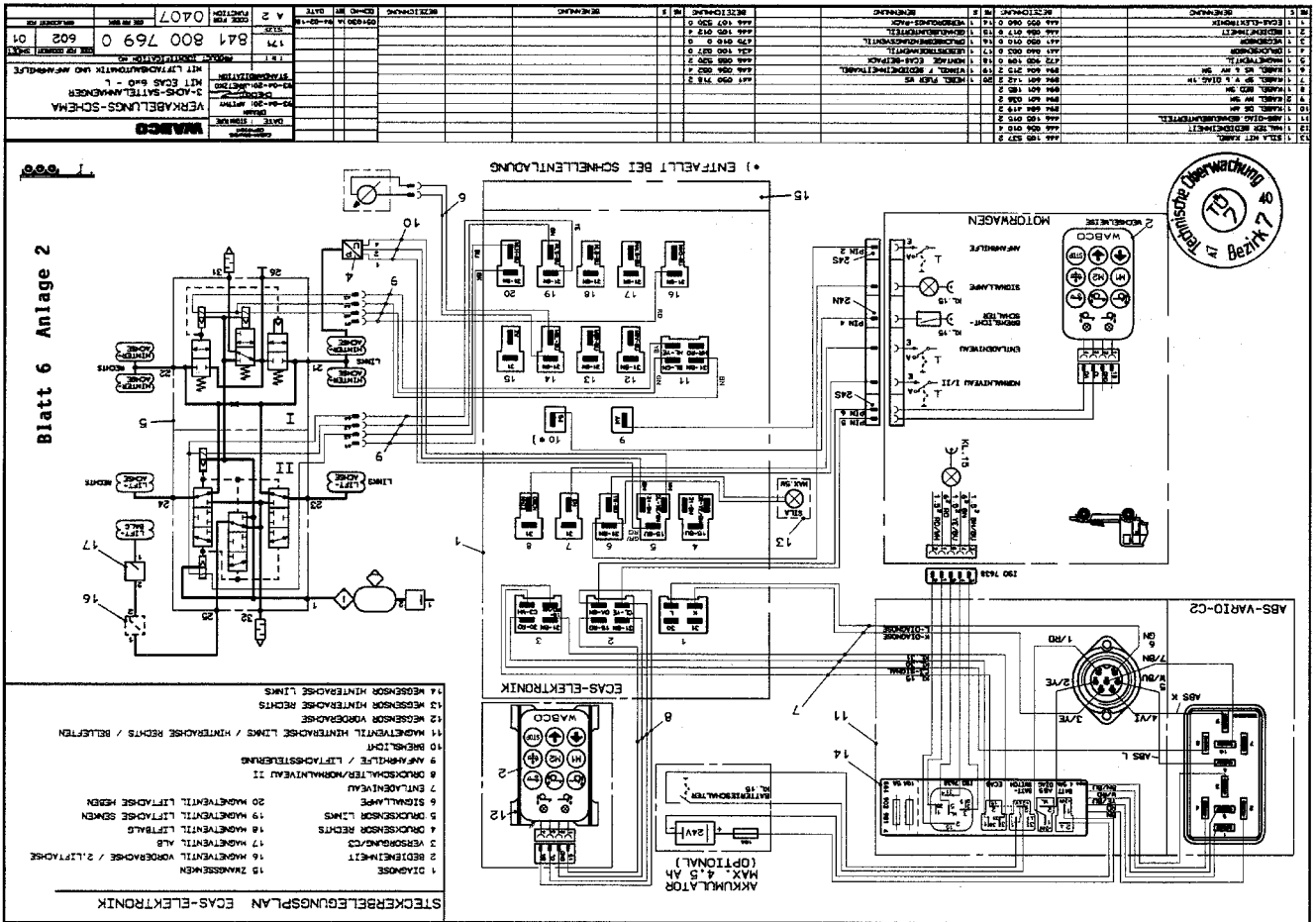

Blatt 5 Anlage 1

WABCO

**WABCO Westinghouse
Fahrzeughydrauliken**
Ein Unternehmensbereich der
WABCO Standard GmbH
HANNOVER, 08.06.1994

KURZBESCHREIBUNG NACH SCHEMA 841 800 769 0

LUFTFEDERSYSTEM FÜR SATTELANHÄNGER MIT LIFTACHSEN, 1-PUNKT-REGELUNG

- ELEKTRONIK 446 055 06. 0
 - GEHÄUSE 446 105 ... 0
 - WEGSENSOR 441 050 ... 0
 - MAGNETVENTIL HALA 472 905 ... 0
- BESTEHEND AUS:
- ▶ 1 X 3/2- WEGVENTIL FÜR BE- UND ENTLÜFTUNG
 - ▶ 2 X 2/2- WEGVENTIL, PARALLEL GESCHALTET, FÜR HINTERACHSE
 - ▶ 3 X 3/3- WEGVENTIL, PARALLEL GESCHALTET, FÜR LIFTACHSE
- BEDEIENEITZEN (OPTIONAL) 446 056 ... 0
- FUNKTIONEN:
- ▶ NORMALNIVEAU-EINSTELLUNG
 - ▶ 2 X MEMORY-NIVEAUEINSTELLUNG
 - ▶ STOPPFUNKTION
 - ▶ HEBEN / SENKEN
 - ▶ HINTERACHSEN
 - ▶ LIFTACHSEN
- DRUCKSENSOR 441 040 0. 0
- FÜR LIFTACHSAUTOMATIK, ANFAHRHILFE, ÜBERLASTSCHUTZ UND REIFENRÜCKGANGSKOMPENSATION
- ▶ HEBEN U. SENKEN DER LIFTACHSE VOLLAUTOMATISCH ODER
 - ▶ SENKEN AUTOMATISCH UND HEBEN MANUELL
- (NICHT DARGESTELLT: OPTION NUR FÜR LIFTACHSTEILAUTOMATIK, DRUCKSCHALTER STATT DRUCKSENSOR)

- SPANNUNGSVERSORGUNG: KL.15, KL. 30, KL. 31
- ▶ AKKUMULATOR (OPTIONAL)

- WARNANZEIGE AM AUFBAU

- GESCHWINDIGKEITSERKENNUNG (C3-SIGNAL V. D. ABS-ECU)

- WEITERE ECU-EIN- UND AUSGÄNGE (OPTIONAL):

- ▶ ANFAHRHILFE
- ▶ ENTLADENIVEAU
- ▶ NORMALNIVEAU II
- ▶ BREMSLICHT
- ▶ ZWANGSENKEN
- ▶ MAGNETVENTIL ALB "VOLLAST"
- ▶ DIAGNOSE NACH ISO 9141



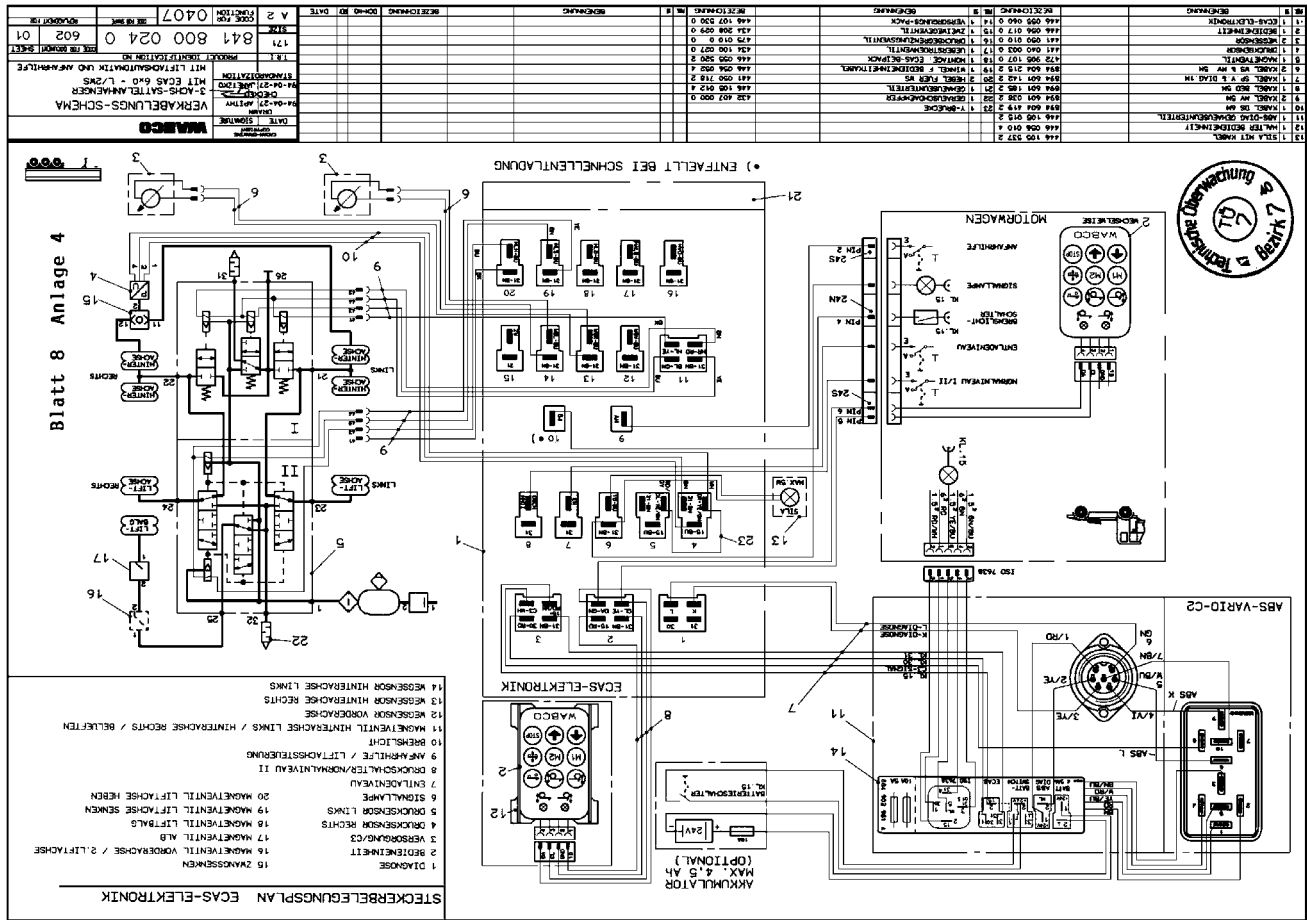

Blatt 7 Anlage 3

WABCO Westinghouse
Fahrzeugbremsen
Einheit für
WABCO Standard GmbH
HANNOVER, 08.06.1994

KURZBESCHREIBUNG NACH SCHEMA 841 800 024 0

LUFTFEDERSYSTEM FÜR SATTELANHÄNGER MIT LIFTACHSEN, 2-PUNKT-REGELUNG

- ELEKTRONIK 446 055 06. 0
 - GEHÄUSE 446 105 ... 0
 - WEGSENSOR (2X) 441 050 ... 0
 - MAGNETVENTIL HA.LA 472 905 ... 0
- BESTEHEND AUS:**
- 1 X 3/2- WEGVENTIL FÜR BE- UND ENTLÜFTUNG
 - 2 X 2/2- WEGVENTIL FÜR HINTERACHSE LINKS/RECHTS
 - 3 X 3/3- WEGVENTIL, PARALLEL GESCHALTET, FÜR LIFTACHSE
- **BEDIENEINHEITEN (OPTIONAL) 446 056 ... 0**
- FUNKTIONEN:**
- NORMALNIVEAU-EINSTELLUNG
 - 2 X MEMORY-NIVEAUEINSTELLUNG
 - STOPFUNKTION
 - HEBEN / SENKEN
 - HINTERACHSEN
 - LIFTACHSEN
- **DRUCKSENSOR 441 040 0. 0**
- FÜR LIFTACHSAUTOMATIK, ANFAHRLIFTE, ÜBERLASTSCHUTZ UND REIFENRÜCKWÄRTSKOMPENSATION
- HEBEN U. SENKEN DER LIFTACHSE VOLLAUTOMATISCH ODER SENKEN AUTOMATISCH UND HEBEN MANUELL (NICHT DARGESTELLT, OPTION NUR FÜR LIFTACHSTEILAUTOMATIK, DRUCKSCHALTER STATT DRUCKSENSOR)
- **SPANNUNGSVERSORGUNG: KL.15, KL. 30, KL. 31**
- AKKUMULATOR (OPTIONAL)
- **WARNTAFEL AM AUFBAU**
- **GESCHWINDIGKEITSERKENNUNG (C3-SIGNAL V. D. ABS-ECU)**
- **WEITERE ECU-EIN- UND AUSGÄNGE (OPTIONAL):**
- ANFAHRLIFTE
 - ENTLADENIVEAU
 - NORMALNIVEAU II
 - BREMSLICHT
 - ZWANGSSSENKEN
 - MAGNETVENTIL ALB "VOLLAST"
 - DIAGNOSE NACH ISO 9141

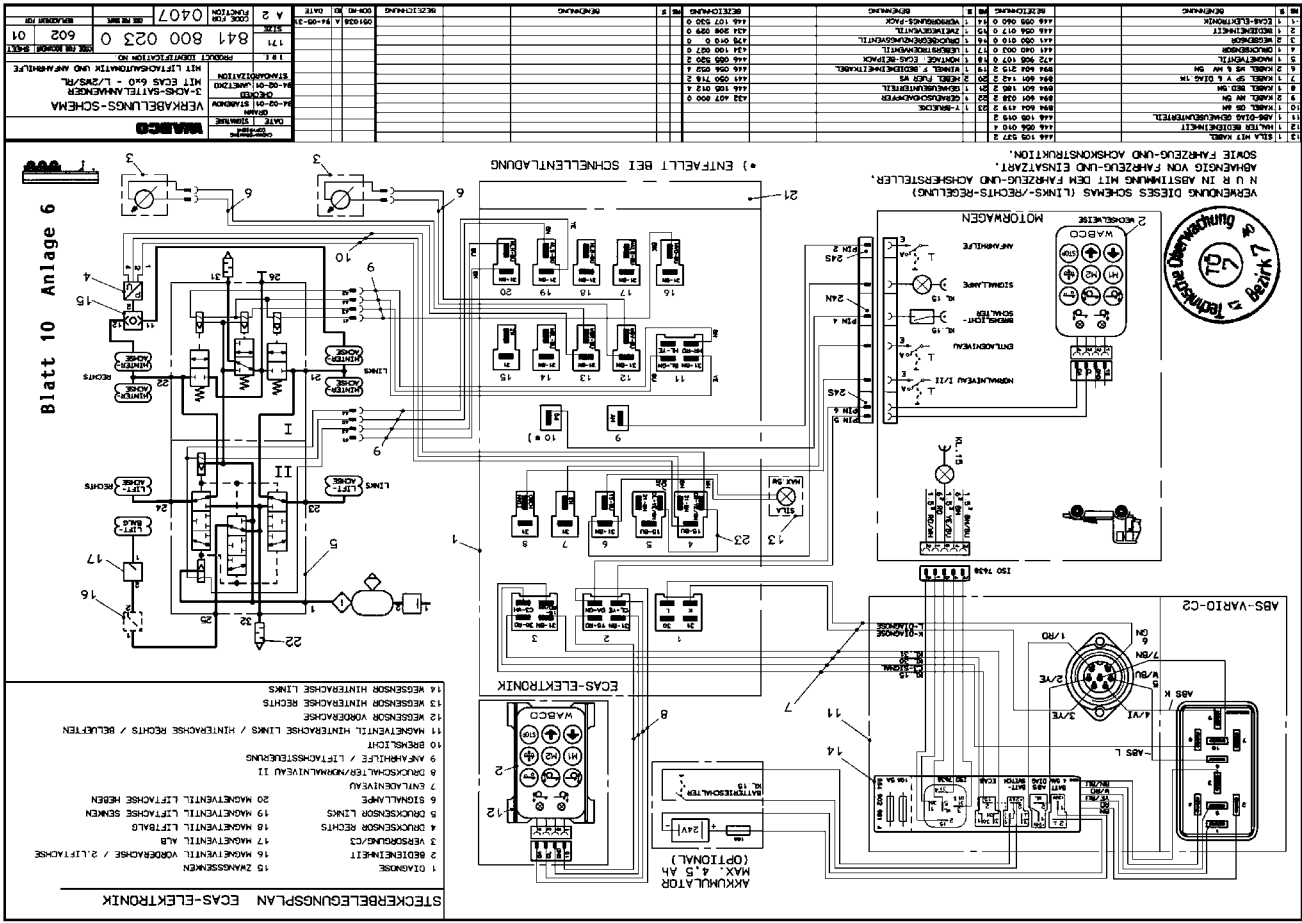

Blatt 9 Anlage 5

**WABCO Westinghouse
Fahrzeugbremsen**
Ein Unternehmen der
WABCO Standard GmbH
HANNOVER, 08.06.1994

KURZBESCHREIBUNG NACH SCHEMA 841 800 023 0

LUFFTEDIERSYSTEM FÜR SATTELANHÄNGER MIT LIFTFACHSEN, 2-PUNKT-REGELUNG

- SEITENWEISES HEBEN/SENKEN MÖGLICH
- LINKE SEITE, VORDERACHSEIN-/AUSGÄNGE DER ECU
- RECHTE SEITE, HINTERACHSEIN-/AUSGÄNGE (RECHTS) DER ECU

- ELEKTRONIK 446 055 06. 0
- GEHÄUSE 446 105 ...
- WEGSENSOR (2X) 441 050 ... 0
- MAGNETVENTIL HA, LA BESTEHEND AUS:
 - 1 X 3/2- WEGEVENTIL FÜR BE- UND ENTLÜFTUNG
 - 2 X 2/2- WEGEVENTIL FÜR HINTERACHSE LINKS/RECHTS
 - 3 X 3/3- WEGEVENTIL, PARALLEL GESCHALTET, FÜR LIFTFACHSE

- BEDIENEINHEITEN (OPTIONAL) 446 056 ... 0
FUNKTIONEN:
 - 1. NORMALNIVEAU-EINSTELLUNG
 - 2. X MEMORY-NIVEAU-EINSTELLUNG
 - STOPFUNKTION
 - HEBEN / SENKEN
 - ⇒ FAHRZEUG LINKS UND/ODER RECHTS
 - ⇒ LIFTFACHSEN

- DRUCKSENSOR 441 040 0.. 0
FÜR LIFTFACHSAUTOMATIK, ANFAHRHILFE, ÜBERLASTSCHUTZ UND REIFENHINDRÜCKUNGSKOMPENSATION
⇒ HEBEN U. SENKEN DER LIFTFACHSE VOLLAUTOMATISCH ODER
⇒ SENKEN AUTOMATISCH UND HEBEN MANUELL
(NICHT DARGESTELLT, OPTION NUR FÜR LIFTFACHSTEILAUTOMATIK, DRUCKSCHALTER STATT DRUCKSENSOR)

- SPANNUNGSVERSORUNG: KL.15, KL. 30, KL. 31
AKKUMULATOR (OPTIONAL)

- WARNANZEIGE AM AUFBAU

- GESCHWINDIGKEITSERKENNUNG (C3-SIGNAL V. D. ABS-ECU)

- WEITERE ECU-EIN- UND AUSGÄNGE (OPTIONAL):

- ▲ ANFAHRHILFE
- ▲ ENTLADENIVEAU
- ▲ NORMALNIVEAU II
- ▲ BREMSLICHT
- ▲ ZWANGSENKEN
- ▲ MAGNETVENTIL ALB "VOLLAST"
- ▲ DIAGNOSE NACH ISO 9141





Technischer Überwachungs-Verein Nord e. V.

Technische Prüfstelle für den Kraftfahrzeugverkehr	Bericht Nr.: 060294	Blatt: 11 von 11
---	---------------------	---------------------

Anlage 7

Bauteilangaben

ECAS-Elektronik	446 055
Magnetventil	472 905
Wegsensor	441 050
Drucksensor	441 040
ECAS-Versorgungsmodul	446 107
Bedieneinheit	446 056
Kontrollleuchte (Sila)	446 105 53
Gehäuse	446 105 01
Kabel m. Gerätesteckdose (3x1 mm ²)	894 604
(3x1,5 mm ²)	894 604
(4x1 mm ²)	894 601
(4x1 mm ²)	894 601
Versorgungsleitung	894 601
Bedieneinheitkabel	894 601

