

Introduction

If we look at the different suspension systems used in motor vehicles today, the most apparent difference between them is that they are either mechanical or air suspension systems.

Both types are, of course, incapable of meeting all technical requirements. If they are, however, directly compared, it soon becomes apparent that air suspension offers major benefits compared with mechanical suspension systems.

As a result air suspension systems are used to an increasing extent in commercial vehicles.

Benefits of Air Suspension Systems

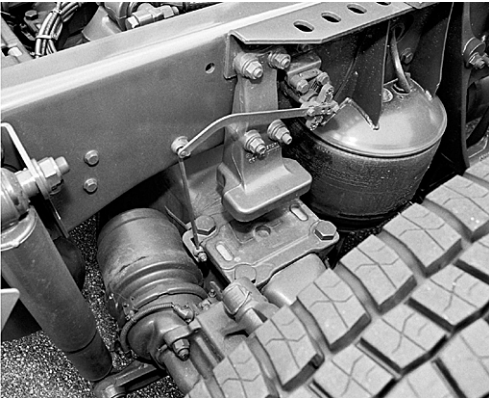

1. By changing the bellows pressure, depending on the load carried on the vehicle, the distance between the road surface and the vehicle's superstructure addresses the same level. This means that the boarding or loading height, and the headlight settings, remain constant.
2. Spring comfort remains almost unchanged across the whole of the loading range; again this is achieved by changing the bellows pressure. The passenger on a motor coach will always perceive the same pleasant type of oscillations. Sensitive loads can thus be carried without being severely damaged. The well-known "jumping" of an unladen or partially laden trailer no longer occurs if an air suspension system is used.
3. The stability of the steering system and the transfer of the braking forces are improved since all wheels always have good adhesion to the road surface.
4. The pressure in the air bellows, depending on the load the vehicle carries, is ideal for use in controlling automatic load-sensitive braking.
5. In the area of control for interchangeable platforms, air suspension systems are an excellent basis for cost-effective loading and unloading of containers.
6. The kneeling effect often required for routine buses can easily be achieved by venting the nearside air bellows.

Purpose

Depending on the levelling valve's control, the air suspension bellows are designed to take up the required pressure in the bellows' volume, depending on the load carried on the vehicle.

Air suspension bellows are used as elastic constructional elements between the axle and the vehicle's superstructure. Since its internal friction is less than that of mechanical suspension systems, the air-sprung vehicle has to have shock-absorbers fitted.

Design types

Today the following variants are mainly used:

Twin Concertina Bellows



Twin concertina bellows show a favourable ratio of height versus spring travel, i. e. this type of bellows permits the lowest installation height.

The beaded heels around the bellows' openings are held by metallic bead rings which are screwed against supporting consoles or plates. This causes part of the bellows' heels to be deformed, thereby achieving a sealing effect.

Rolling Tube Bellows

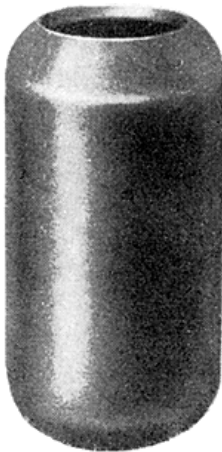

Rolling tube bellows achieve an excellent cushioning effect and offer exceptionally good lateral movement. For this reason they are particularly suitable for use in buses and passenger cars but are also used on lorries and trailers.

In the course of their cushioning action, these bellows roll on a cylindrical or similar piston whose shape essentially effects the cushioning characteristic. This allows the natural frequency to be varied and the best possible suspension for the vehicle to be achieved. For this purpose, rolling tube bellows require no additional volume. The air volume in the piston can also be used for cushioning.

These bellows are fairly easy to install and to seal. The bellows' heels are pushed onto conical fittings and assume their intended position when connected to the air line.

Maintenance

No maintenance is required beyond the checks required by law.

Testing

Air suspension bellows merely need to be checked for any leakage, and for mechanical wear.

Purpose

Levelling valves, also called air suspension valves, are used to control the suspension in air-sprung vehicles. Their purpose is the sensitively graded control of the compressed air for the air suspension bellows as a ratio of the vehicle's load.

Design types

464 002 ... 0



Levelling valves with single or double-stage characteristic curve. The damping nozzles for energy delivery to the air suspension bellows varies with the respective variants (1.3 mm resp. 3 mm). They use either a flat lever with a ball joint, or a linkage with a rubber transmitting member.

464 006 ... 0



Levelling Valve 464 006 ... 0

Devices (in dual level characteristic) replace the designs 464 002 ... and have a nominal width of 3 mm.

There are following design types:

Levelling Valve 464 006 00. 0 (without height limitation)

The device is available in different variants (with or without lever resp. silencer).

They use either a flat lever with a ball joint, or a linkage with a rubber transmitting member.

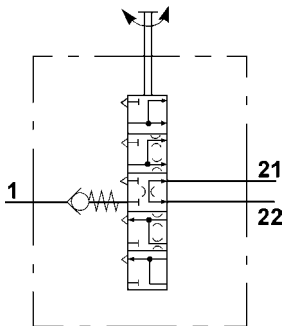

Levelling Valve with height limitation 464 006 100 0.

This variant has an additional 3/2 way valve which closes, from a special adjustable lever angle up, the pressure supply to the air bellows and turn into a venting position when the lever further is actuated.

Through this "Height Limitation" a lift up of the vehicle with the rotary slide valve over the admissible level is prevented. This integrated solution makes the former necessary separate shutoff valve for stroke limitation superfluous.

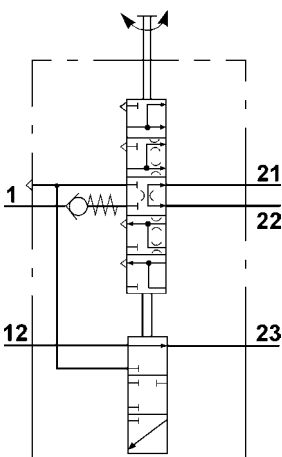

Operation of Levelling Valve 464 002

a. Pressurizing Position

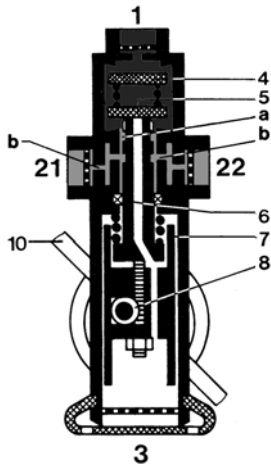

If the vehicle is pressureless, its superstructure rests on the rubber buffers of the chassis. The levelling valve has thus been reversed via the linkage (10), causing the valve (5) on the inlet side to open. The compressed air from the air suspension's auxiliary air reservoir now enters at port (1), opening the check valve (4), and flows through the open valve (5) past the tappet (6) into chamber (a). Through the calibrated nozzle holes (b), the compressed air flows to ports (21 and 22) and from there to the air suspension bellows. As the vehicle's superstructure rises, it simultaneously acts on the eccentric pin (8) via the linkage (10). This causes the guide (7), together with the tappet (6), to be pulled downwards. When the level for loading the vehicle, or for boarding passengers, has been reached, the inlet side of the valve (5) closes, and the process of pressurizing is finished. Because of the groove-shaped top of the tappet (6), the nozzle holes (b) are now covered.

b. When Axles Oscillate

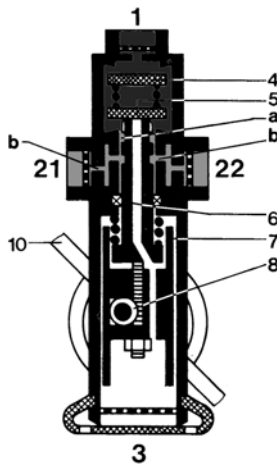

Any axle oscillations, caused by uneven road surfaces as a ratio of the vehicle's speed, are transferred directly to the levelling valve. Although this may cause the valve (5) to open, the air consumption is kept to a minimum because the nozzle holes (b) are covered by the tappet (6).

c. When Loading

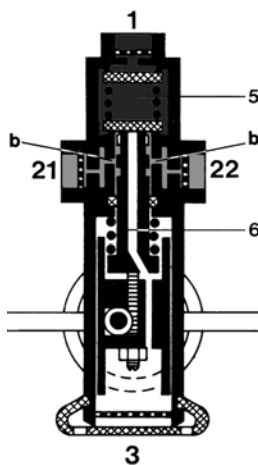

When the vehicle is being loaded, the existing bellows pressure is no longer sufficient to keep the superstructure at its level. It moves downwards, causing the tappet (6) to reverse via the guide (7). The inlet side of the valve (5) opens, and the tappet (6) releases the nozzle holes (b), allowing compressed air at a higher pressure to flow to the connected air suspension bellows. As described under "a" above, the levelling valve reverses as the vehicle's superstructure is raised.

d. When Unloading

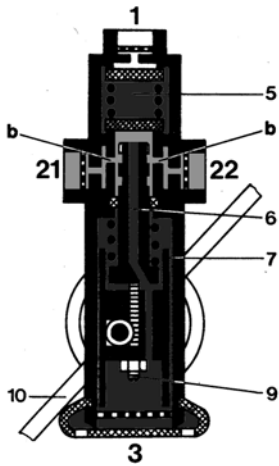

When the vehicle is unloaded, the levelling valve is controlled in reverse order. Its superstructure rises, moving the guide (7), together with the tappet (6), downwards via the linkage (10). As the tappet (6) is raised off the valve (5), the nozzle holes (b) are released and the air suspension bellows are connected with the levelling valve's exhaust (3). As the pressure in the air suspension bellows is reduced, the vehicle's superstructure drops and the levelling valve is set back to its original position in which its **air intake and its exhaust are closed**.

Testing

Provided the air suspension bellows have the required pressure, the levelling valve is only checked for any leakages, and for mechanical wear of the linkage.

Important Note

The factory setting of the levelling valve should not be changed in terms of its empty stroke via the adjusting screw (9), or the centering plate's Phillips screws, since this would neutralize its basic setting.

Schematic for Testing and Installation

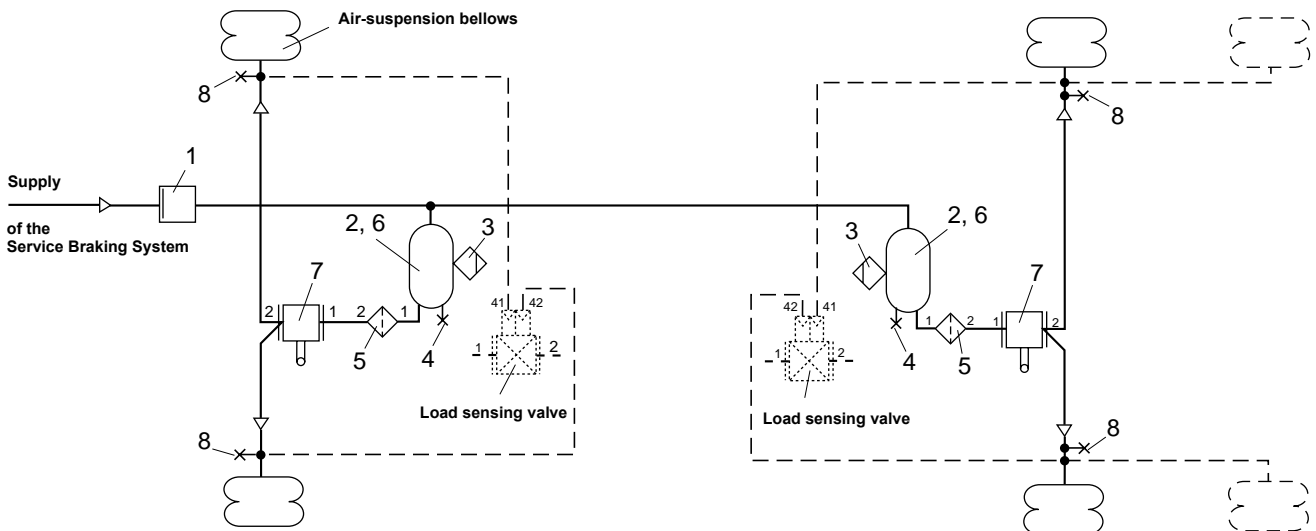

After mounting the air levelling valve, the lever length is adjusted following the vehicle manufacturer's instructions. For adjusting the valve at the vehicle it is decisive which total spring travel the axle permits.

When the air suspension bellows are pressureless, the vehicle's superstructure rests on the rubber buffers of the chassis. As the bellows are pressurized, the superstructure is raised.

When the air suspension bellows' "unladen" level (level for loading or for mounting passengers) has been reached, the lever on the valve is moved to its neutral position. To facilitate the installation and adjusting of lever and connecting linkage the levelling valve shaft can be fixed by plugging a parallel pin of $\varnothing 3$ mm in the idle position.

If the vehicle is at a normal level, the connecting linkage can be installed. The linkage has to be aligned vertically.

instructions of the vehicle or Achsherstellers) betragen. If a shorter lever has to be used, a higher air consumption of the levelling valve has to be concerned.

Depending on the fitting position various cranks of the lever are possible. By accordingly fixing or turning the lever for 180° the valve can be optionally operated from right or left. Depending on the final installation position - vertical or horizontal - the lever is to be placed through one of the two bores in the operating shaft which are displaced to each other for 90° .

Variant ... 100 0 is adjusted to a closing angle of $30^\circ \pm 2^\circ$ by plant. The pilot pressure is 15 - 45° bar. A closing angle of 15° is not permissible, otherwise the cross-section will reduce itself and this can lead to complete closing.

For adjustment of the closing angle the rubber plug underneath the 3/2-Directional Control Valve has to be removed to adjust the adjusting screw with a Torx T30 screwdriver:

- Counterclockwise means a reduction of the closing angle, clockwise means an increasing.
- A rotation = approx. 10° changing of the angle

After the vehicle has been lowered to its buffers with the help of a rotary valve the height of the chassis has to be measured. Then the chassis has to be raised by the rotary valve. Should the permissible full suspension be achieved before the Height Limitation of the levelling valve sets in, the raising has to be cancelled and the vehicle has to be lowered. Turning the adjusting screw counterclockwise the closing angle and also the suspension way are reduced.

If the height limitation sets in before the chassis is at the required hub height, the vehicle has to be lowered also in this case. Turning the adjusting screw counterclockwise the closing angle and also the suspension way are reduced. This process has to be repeated until the required suspension way (equal or less than the maximum suspension way given by the axle producer) is achieved. The final braking position has been reached.

Important

The transfer linkage and the lever of the levelling valve need not to be in one line, because the linking is turning around and this could cause damages on the levelling valve.

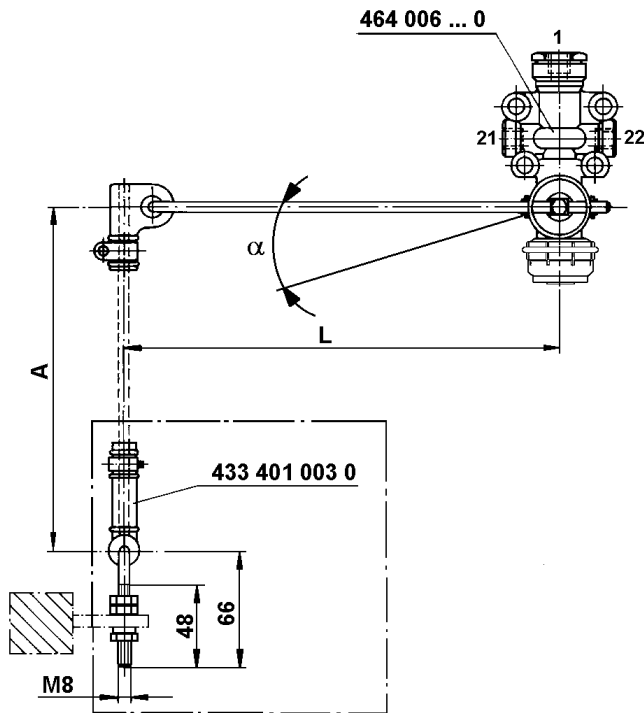

The space A between the fulcrum on the levelling valve lever and the fulcrum on the angle bracket should not be less than 150 mm. The linking 433 401 003 0 has to be ordered separately.

The relation lever length L / rod length A should be ≤ 1.2 if the closing angle of max. 45° is not exceeded. The lever length "L" should be 175 to 295 mm (following the



Purpose:

Control of raising / lowering of air suspended interchangeable platforms and semitrailer chassis (lifting device).

The rotary slide valve 463 032 1.. includes the deadman control meeting the accident prevention requirement of the metal professional association (German VBG 8, § 8). An automatic return is required for chassis movement with a **stroke more** than 300 mm, measured at the axle.

With these valves, the lever automatically returns to raise/stop respectively lower/stop, all other functions are like described below.

Operation:

In the "driving"-position of the hand lever the lifting device is turned off. The rotary slide valve has an open passage between the levelling valves (port 21 to 23) and the bellows (ports 22 and 24)

Upon that, this device enables 4 further lever park positions allowing pressurizing/ venting of the bellows for raise/ lower function.

To raise the chassis, the lever is dislocked by pressing it down axially and then turned across position "stop" to position "raise". This will close ports (21 and 23) and connect the bellows (22 and 24) with reservoir at port 1.

After reaching the required height, the hand lever is to be turned to "stop" position. In this position, all ports to the levelling valve (21 and 23) as well as those to the bellows (22 and 24) are closed. Support arms can now be turned out.

The afterwards required lowering of the chassis under normal level and place down a container or the loading platform and to drive out is done with the hand lever position "lower". Like in the position "raise", the ports (21 and 23) are now closed. However, the bellows (22 and 24) are vented over exhaust 3.

After driving out of the chassis the hand lever is to switched to "driving" position to switch back to level control with levelling valves. After driving out of the chassis the hand lever is to switched to "driving" position to switch back to level control with levelling valves.

Maintenance:

No maintenance is required beyond the checks required by law.

Installation recommendation:

The rotary slide valve has to be fitted vertically or horizontally with 4 M8 screws - exhaust 3 pointing downwards. The unassembled supplied plate with the lever positions has to be installed underneath the lever (see "fitting dimensions").

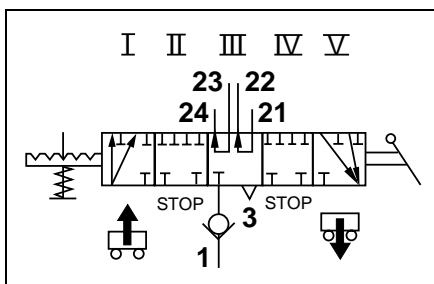

Schematic for Testing and Installation for Trailers

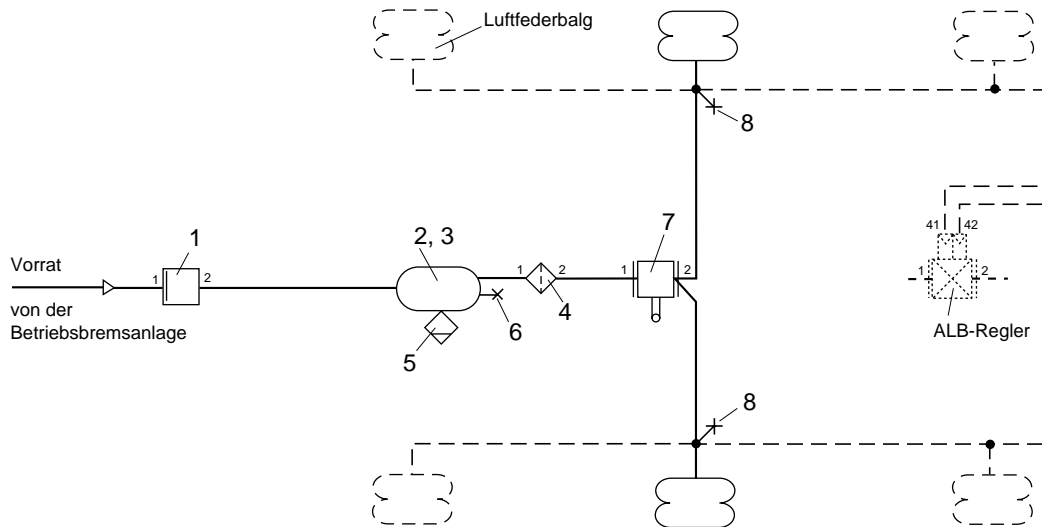

Pos.	Units	Description	Order number
1	1	Charging Valve without return flow 6.0 bar	434 100 125 0
2	1	Air reservoirs	950 0
3	2	Clamps	451 901 10 . 2
4	1	Line filter	432 500 02 . 0

Pos.	Units	Description	Order number
5	1	Drain valve	934 300 001 0
6	1	Test Connection	463 703 100 0
7	2	Levelling Valve	464 006 002 0
8	2	Test Connection	463 703 . . . 0

for semitrailer (24V) (Raising/Lowering)

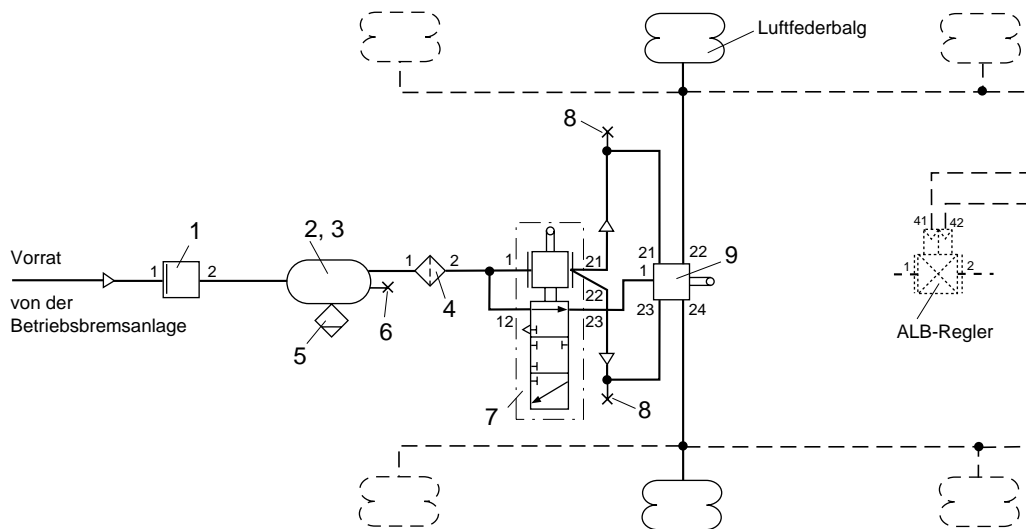

Pos.	Units	Description	Order number
1	1	Charging Valve without return flow 6.0 bar	434 100 125 0
2	1	Air reservoirs	950 0
3	2	Clamps	451 999 . . . 2
4	1	Line filter	432 500 02 . 0

Pos.	Units	Description	Order number
5	1	Drain valve	934 300 001 0
6	1	Test Connection	463 703 100 0
7	1	Levelling Valve	464 006 100 0
8	2	Test Connection	463 703 . . . 0
9	1	Rotary Slide Valve	463 032 . . . 0



Purpose:

The lifting axle compact valve is in charge of lowering or raising the lifting axle(s) manually or automatically, if the axle(s) that are down have reached their maximum load.

Variants

- 463 084 000 0 mechanically operated version
- 463 084 010 0 electrically operated version
- 463 084 020 0 fully automated pneumatic version

Operation:

For lowering the lifting axle compressed air flows via port 21 (air-suspension bellows) through the duct (k), through the throttling port of the check valve (d) to port 41 (expansion tank) and through duct (f) into chamber B. After reaching the switch pressure which is adjusted by the screw (c) the piston (e) is raised. The compressed air flows via duct (g) into chamber A and moves the tappet (b) into its superior final position. Port 1 (supply) is closed. Port 20 and the chambers D and E are connected with vent 3. The tappets (h and i) move towards the lower stop and the bellows (21 with 22) and (23 with 24) are connected.

For raising the lifting axle the actuation button (a) has to be pushed (only possible when piston (e) is lowered) and the supply air flows via port 20 to the downstreamed lifting bag. At the same time the compressed air flows via duct (j) into the chambers D and E, moves the tappets (h and i) against the power of the compression spring upwards. The connection of the bellows (21 with 23) and (23 with 24) is closed and compressed air from the bellows of the lifting axle (port 22 and 24) is venting through the tappets (h and j), chamber C and exhaust 3 to atmosphere.

Funktion of port 42 refer to p. 75.

Maintenance:

No maintenance is required beyond the checks required by law.

Installation recommendation:

The fixing can made with the help of 3 M6 stud bolts [A] (torque 10 Nm) or 2 M8 screws [B], torque 20 Nm, (wholes 9 mm available on the appliance).

The fitting position for the lifting axle control valve is shown on page 70.

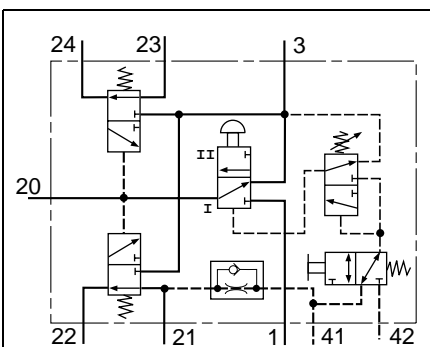

Variant 000

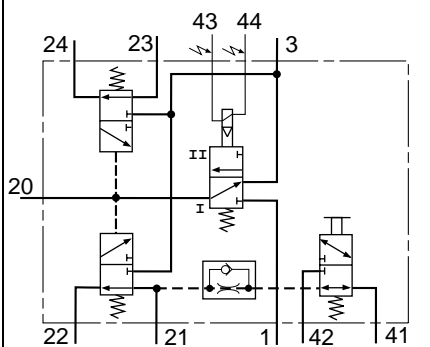

Variant 010

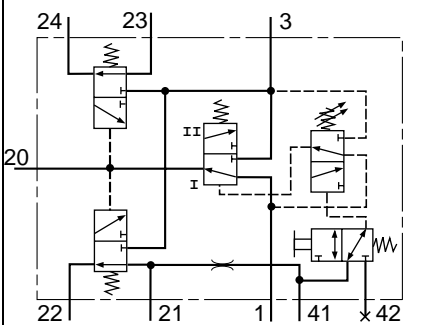

Variant 020

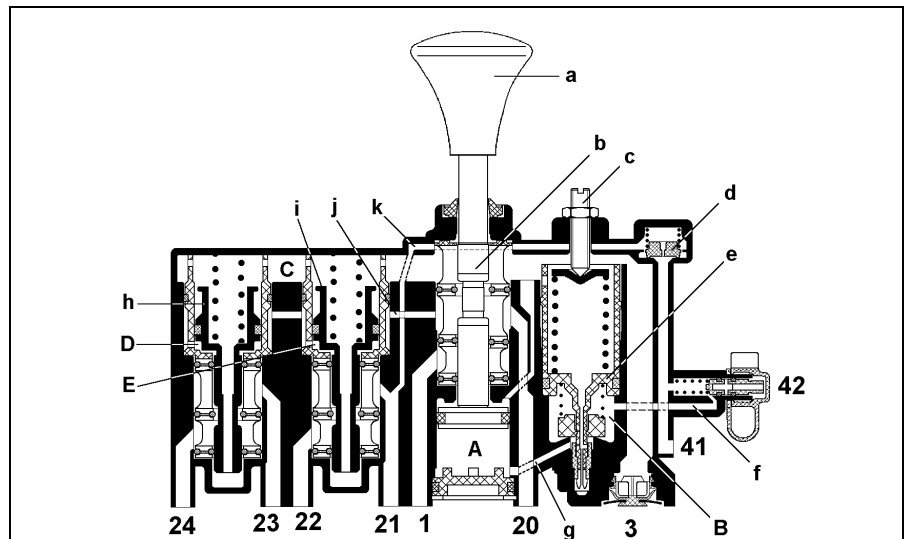

Lifting Axle Circuit electronically operated

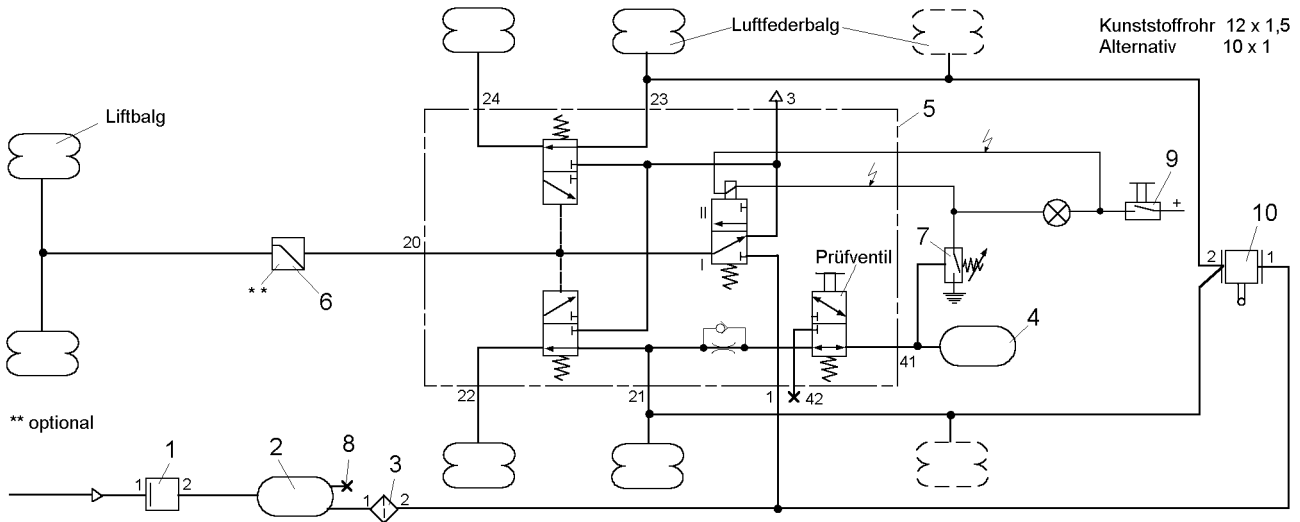

Pos.	Un its	Description	Order number
1	1	Charging Valve	434 100 125 0
2	1	Air reservoirs	950 0
3	1	Line filter	432 500 020 0
4	1	Air reservoirs	950 410 004 0
5	1	Lifting axle valve	463 084 010 0

Pos.	Un its	Description	Order number
6	1	Pressure limiting valve	475 010 . . . 0
7	1	Pressure switch	441 042 000 0
8	1	Test Connection	463 703 100 0
9	1	Switch	
10	1	Levelling Valve	464 006 . . . 0

Lifting Axle Circuit mechanically operated

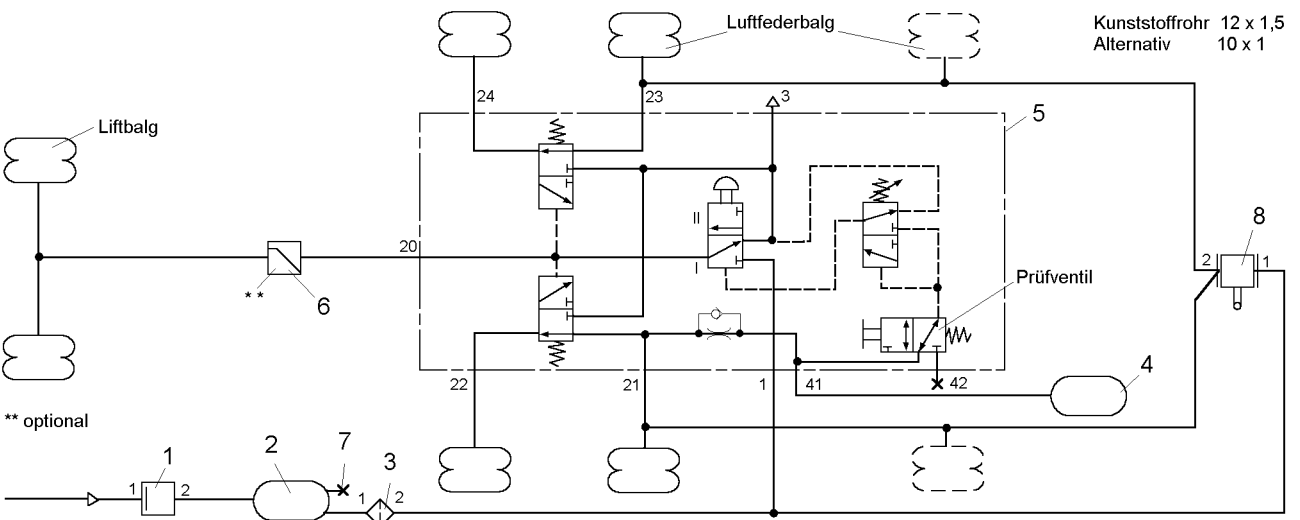

Pos.	Un its	Description	Order number
1	1	Charging Valve	434 100 125 0
2	1	Air reservoirs	950 0
3	1	Line filter	432 500 020 0
4	1	Air reservoirs	950 410 004 0

Pos.	Un its	Description	Order number
5	1	Lifting axle valve	463 084 000 0
6	1	Pressure limiting valve	475 010 . . . 0
7	1	Test Connection	463 703 100 0
8	1	Levelling Valve	464 006 . . . 0

Setting Instruction

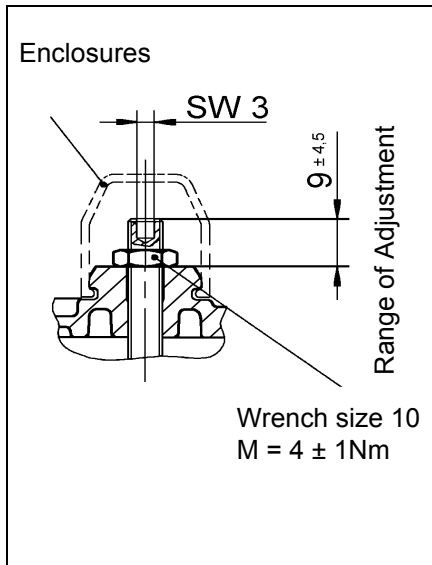

After the valve has been installed according to the fixing instruction and the scheme, the adjustment of the switch pressure has to be made.

1. 463 084 000 0

mechanically operated version
(Diagram 841 801 448 0 see p. 32)

Actuation button (a) has to be pushed.

The switch pressure for lowering the lifting axle has to be set according to the pressure, at which it is made sure, that the permissible axle load is not exceeded.

Therefore a test hose with pressure gauge and pressure reduction valve has to be connected with test connection 42. The compressed air flows via duct (f) into chamber B. By increasing the pressure of the test hose the switching point on which the actuation button springs out is detected, port 20 is getting pressureless (lifting axle lowers) and the air supply of the bellows on the lifting axle sets in.

If the switch pressure is too high, it

can be lowered by turning the adjusting screw counterclockwise. If it is too low, it can be raised by turning the adjusting screw clockwise.

While checking the test pressure always has to be raised from 0 bar on because the hysteresis has to be switched off.

After setting the adjustment screw has to be locked and covered with the enclosed cap.

2. 463 084 010 0

electrically operated version
(Diagram 841 801 447 0 see p. 32)

According to the scheme the pressure switch 441 042 000 0 (Range of Adjustment 1.0 to 5.0 bar) has to be connected.

The setting of the pressure switch is like the setting of the mechanically operated lifting axle valve.

3. 463 084 020 0

fully automated pneumatic version
(Diagram 841 801 449 0 see page 33)

2 switching pressures have to be adjusted.

At first the protection cap has to be removed with SW30 (M = 45 ± 5 Nm) and the Philips screw A (size 2) has to be turned in until stop.

Now the adjustment of the switch pressure for the lowering of the lifting axle (screw B) follows with a 12 mm wrench for hexagon head cap screws almost like the adjustment of the mechanically operated version.

Afterwards the adjustment of the switch pressure for the automatic raising has to be made with the help of a Philips screwdriver (size 2). For this the test pressure of 8.0 bar has to be lowered. The pressure difference of the switch pressures for the automatic lowering and raising has to be 0.4 bar higher than the difference in pressures for the air suspension bellows between lifted and non-lifted axle.

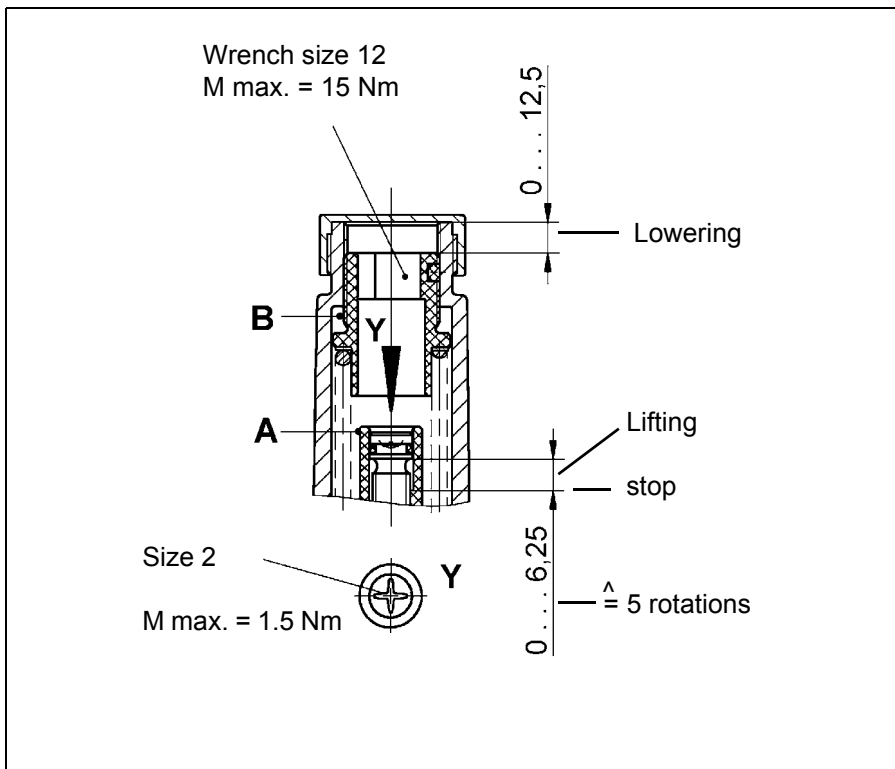



Picture 1: ECAS parts for vehicles

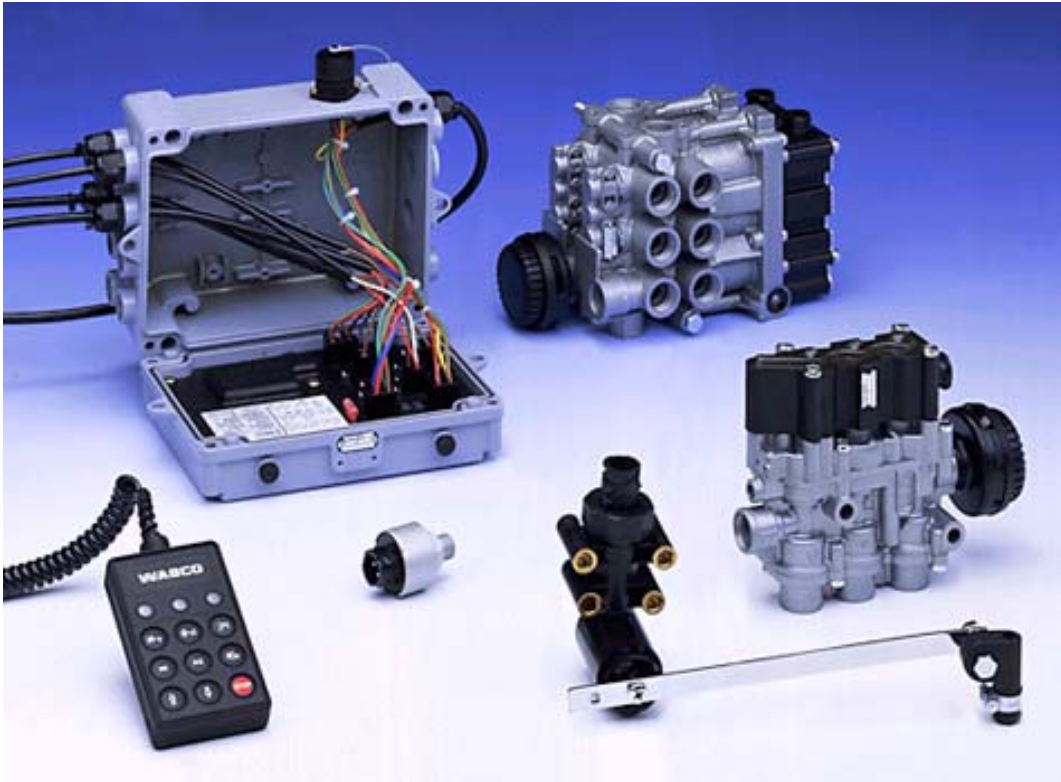

Picture 2: ECAS parts for trailers

Introduction:

ECAS stands for

Electronically
Controlled
Air
Suspension

ECAS is an electronically controlled air suspension system with a large number of functions included in the system. The use of an electronic control unit has achieved major improvements over the conventional system:

- q Reduction of air consumption whilst the vehicle is moving.
- q It is possible to maintain different levels (e. g. ramp operation) by means of automatic readjustment.
- q In the case of complex systems, installation is easier because less pipes are required.
- q Additional functions like the programmable vehicle levels, tyre deflection compensator, overloading protection, traction help and automatic lifting axle control can be easily integrated.
- q Due to large valve diameters, pressurizing and venting processes are accelerated.
- q Easy operations and maximum safety for those operating the system due to one single control unit.

q Highly flexible system due to the fact that electronics can be programmed via operating parameters (trailing end programming).

q Distinctive safety concept and diagnosis facility.

Unlike mechanically controlled air suspension systems in which the valve which measures the height also controls the air bellows, ECAS achieves control by means of an electronic control unit (ECU) which actuates the air bellows via solenoid valves, using information received from sensors.

In addition to controlling the vehicle's level, the ECU, together with the remote control unit, also controls functions which if implemented with conventional air suspension systems, requires a large number of valves.

Furthermore with ECAS additional system functions are available.

ECAS is adjustable to suit the different types of trailer.

For trailers, power is supplied from the ABS or the EBS system. In addition to that the ABS system, provides ECAS with the so-called C3 signal, i.e. information on the vehicle's current speed.

To permit adjustment of the level of a trailer not connected to a towing vehicle, an optional facility for a storage battery may be provided for an additional power supply on the trailer.

Sample function: Trailer without lifting axle

Basic system:

- 1 ECU
- 2 remote control
- 3 height sensor
- 4 solenoid valve
- 5 bellow

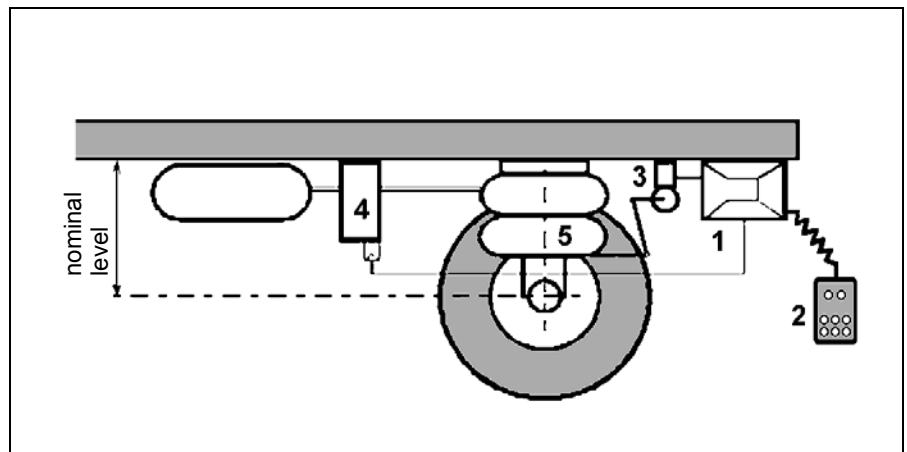

Functional description

A height sensor (3) permanently evaluates the vehicle's height and send its readings to to the ECU (1). If the ECU recognises that the normal level is not being maintained, a solenoid valve (4) is activated in such a way that - by pressurizing or venting - the level is adjusted accordingly.

A flashing of this lamp indicates a fault within the systems which was discovered by the ECU (Electronic Control Unit).

Scheme of the basic system:

- 1 ECU (Electronic)
- 2 Remote control unit
- 3 Height sensor
- 4 Solenoid valve
- 5 Air-suspension bellows

Via a remote control unit (2) the user can change the reference level (important for e. g. rampdriving) underneath a given speed threshold (during standstill).

An indicator lamp is used to notify the driver that the trailer is outside its normal ride height.

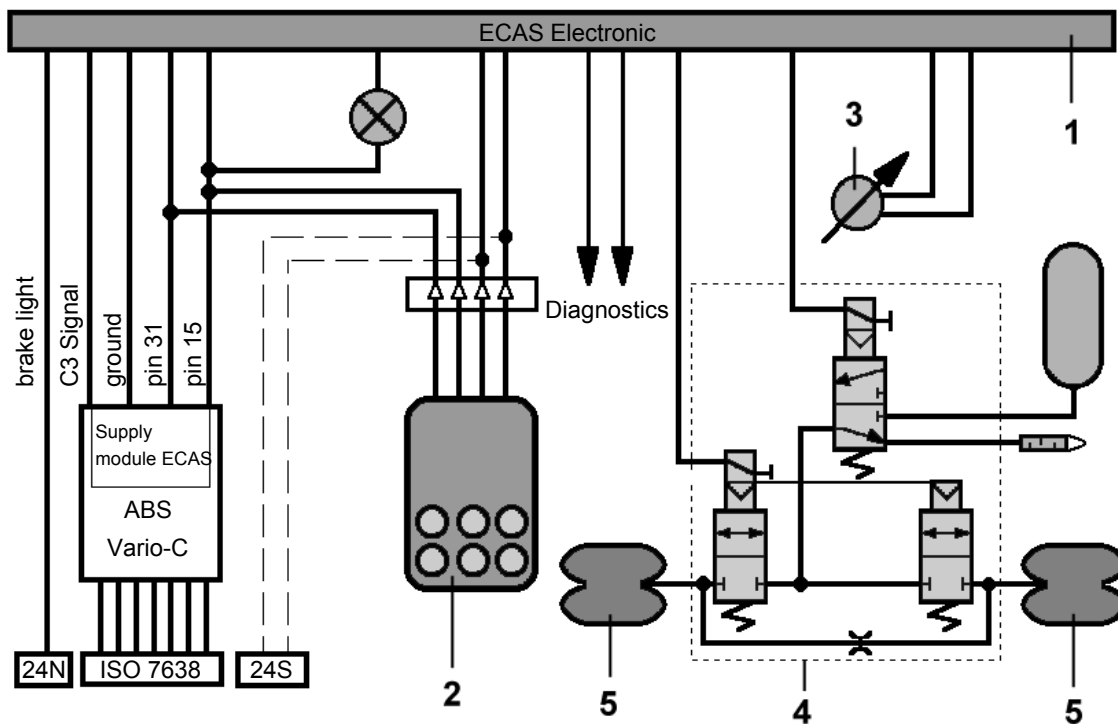

ECAS Electronic (ECU) 446 055 . . 0

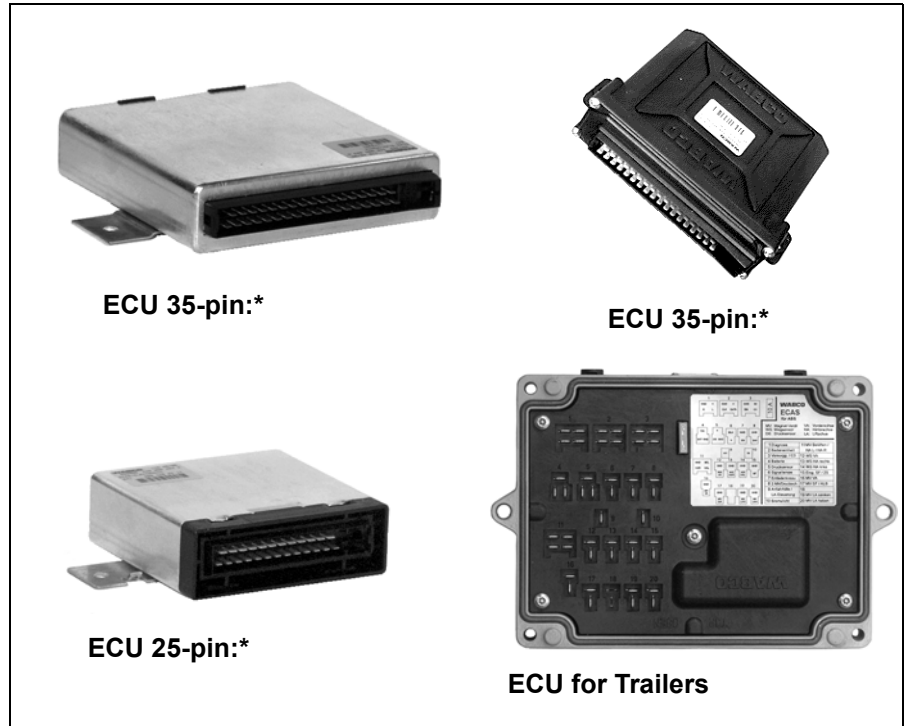

The Electronic Control Unit (ECU)

The Electronic Control Unit is the heart of the system and is connected with the singles components on the vehicle ba means of a 35-pole or 25-pole plug-in terminal. The ECU is located in the driver's cab.

Together with a plug-in terminal for connecting the ECAS ECU for trailer's to the other components, the ECU is mounted on the trailer's chassis in a protective housing. This protective housing corresponds to the ABS-VARIO-C System. The ECU can be used for implementing a large number of system configurations. The plug-in terminal has a connector for each height sensor, pressure sensor and solenoid valve. Depending on the system used, parts of the terminal may not be used.

As in the ABS-VARION-C system the cables are fed through glands in the lower part of the housing.

Function

The ECu contains a microprocessor which processes digital signals only. A memory managing the data is connected to this processor.

The outlets to the solenoid valves and to the indicator lamp are switched via dirver modules.

The ECU is responsible for

- constantly monitoring the incoming signals
- converting these signals into counts
- comparing these values (actual values) to the values stored (index values)
- computing the required controlling reaction in the event of any deviation
- actuating the solenoid valves

Additional responsibilities of the = Electronic control unit

- managing and storing the various index values (normal levels, memory, etc.)
- data exchange with teh RCU and the Diagnostic Controller
- regularly monitoring the function of all system components

- monitoring the axle loads (in systems with pressure sensor)
- plausibility testing of the signals received (for error detection)
- error recovery.

In order to ensure swift control reactions to any changes in actual values, the micro-processor cyclically processes a read-only program within fractions of a second (25 milliseconds), one program cycle meeting all of the above requirements.

This program cannot be modified and is fixed in a program module (ROM).

However, it accesses numerical values which are stored in a freely programmable memory. These values, the parameters, effect the computing processes and thus the ECU's controlling reactions. They are used to communicate to the computing program the calibrating positions, the system configuration and the other preset values concerning the vehicle and functions.

solenoid valves

Special solenoid valve blocks have been developed for the ECAS system. By combining several solenoid valves in one compact block, both space and installation time are kept to a minimum. The solenoid valves are actuated by the ECU as a control element; they convert the voltage present into a pressurizing or venting process, e.g. they increase, reduce or maintain the air volume in the bellows.

In order to achieve a large throughput of air, pilot valves are used. The solenoids initially actuate those valves with a small nominal width, and their control pressure

is then passed to the piston surface of the actual switching valves (NW 10 and NW 7 respectively).

Different types of solenoid valves are used, depending on the application: For controlling a single axle, one seat valve is sufficient whilst a complex sliding valve is required for controlling the lifting axle.

Both types of solenoid valves are based on a modular principle: Depending on the application, the same housing is used to accommodate different parts of valves and solenoids.

ECAS solenoid valve 472 900 05 . 0

Valve for axle with two height sensors

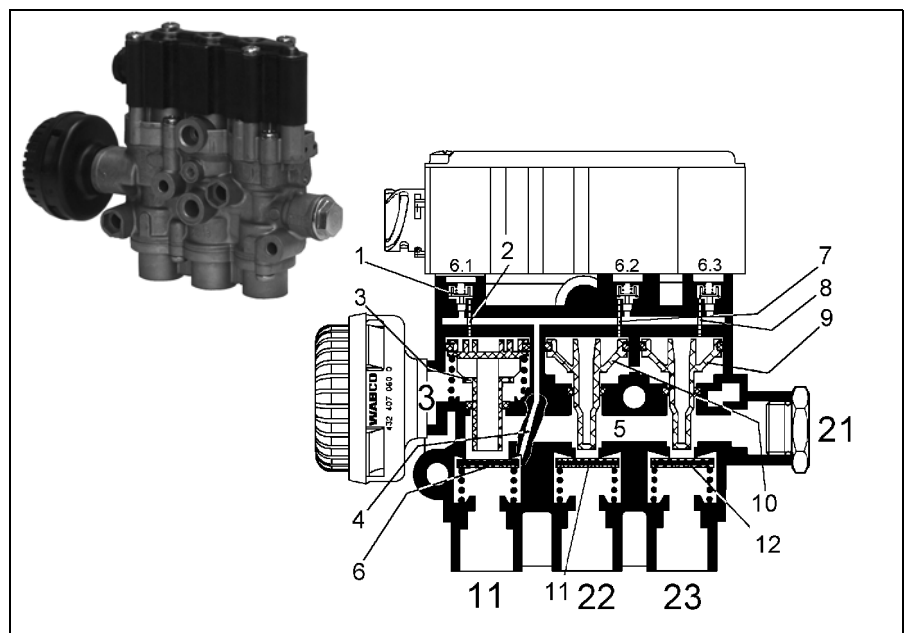

The solenoid valve shown in the illustrations below has three solenoids. One solenoid (6.1) controls a central breather valve (also known as a central 3/2 directional control valve), the others control the connection between the two air bellows (2/2 directional control valves) and the central breather valve. This valve can be used for establishing what is known as 2-point control in which both height sensors on both sides of the axle separately control the level of both sides of the vehicle so that the body kept horizontal even when the load is not evenly distributed.

Design of the valve

Solenoid 6.1 actuates a pilot valve (1), and the actuating pressure from this valve flows through hole (2) and acts on piston valve (3) of the breather valve. The pilot valve receives its pressure via

port 11 (supply) and connecting hole (4). This drawing shows the breather valve in its venting position in which air from chamber (5) can flow to port 3 via the hole of the piston valve. As solenoid 6.1 is energized, piston valve (3) is pushed downwards, initially causing valve plate (6) to close the hole of the piston valve. The valve plate is then pushed off its seat (hence the name 'seat valve'), and supply pressure can flow into chamber (5).

The other two valves connect the air suspension bellows with chamber (5). Depending on which solenoids (6.2 or 6.3) are energized, piston valves (9) or (10) are pressurized via holes (7) or (8), opening valve plates (11) and (12) to ports 22 and 23.

A solenoid valve for control of the other axle can be fitted to port 21.

ECAS solenoid valve 472 900 02 . 0

Valve for an axle with one height sensor

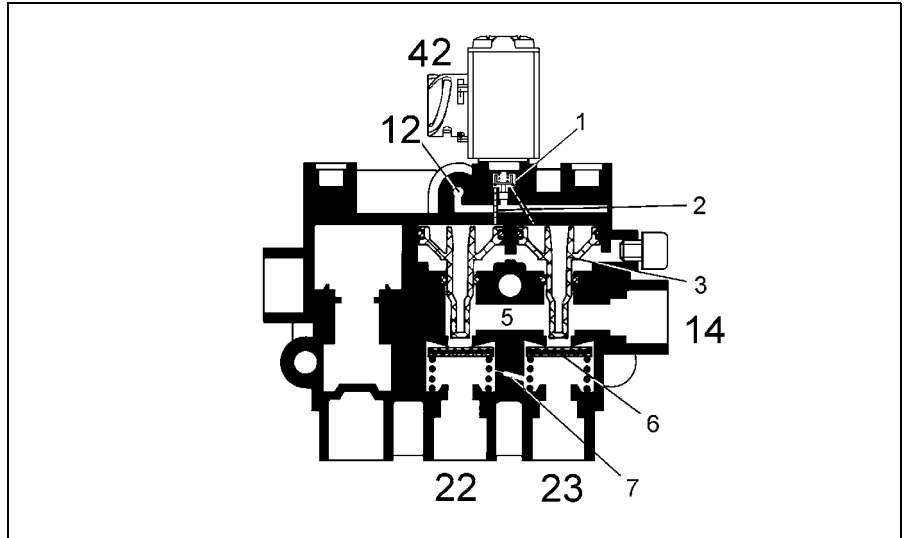

This valve is similar to the valve described above but it contains fewer parts.

Since port 14 is connected to port 21 of the valve described above, no breather valve is needed and only one pilot valve (1) is used. The piston valves (3) of both air suspension bellows valves are pressurized via two connecting holes (2) so that each pressurizing or venting process is effected evenly for both bellows via chamber (5).

If the solenoid is not energized, the valves are closed, as shown in the illustration. At this time, the only connection between the bellows is the lateral choke (7), through which any difference in pressures can gradually be compensated.

The valve is connected to the air supply via port 12. This port is needed merely to permit the pilot valve to displace the piston valve.

ECAS solenoid valve 472 905 1 . . 0

Sliding valve with rear axle block and lifting axle block



ECAS solenoid valve 472 900 05 . 0

Valve for the bus with kneeling function

ECAS Remote Control Unit 446 056 . . . 0



By means of the RCU the driver can influence the vehicle's level within the permissible maximum limits. However, this can only be done whilst the vehicle is either stationary or has not exceeded the driving speed parameter.

The control keys for changing the level are accommodated in a handy housing. Contact with the ECU is established via a coiled cable and a socket on the vehicle.

There are different RCUs depending on the type of system used. The above illustration shows a unit with the largest possible number of functions. The functions of this RCU are:

- raising and lowering of the chassis
- setting normal level
- stop
- storage and actuation of three preference levels
- raising and lowering the lifting axle
- unloading or loading the trailer axle
- Switching automatic lifting axle operation on and off
- activating of the Stand-By mode.

ECAS Heightsensor 441 050 0 . . 0

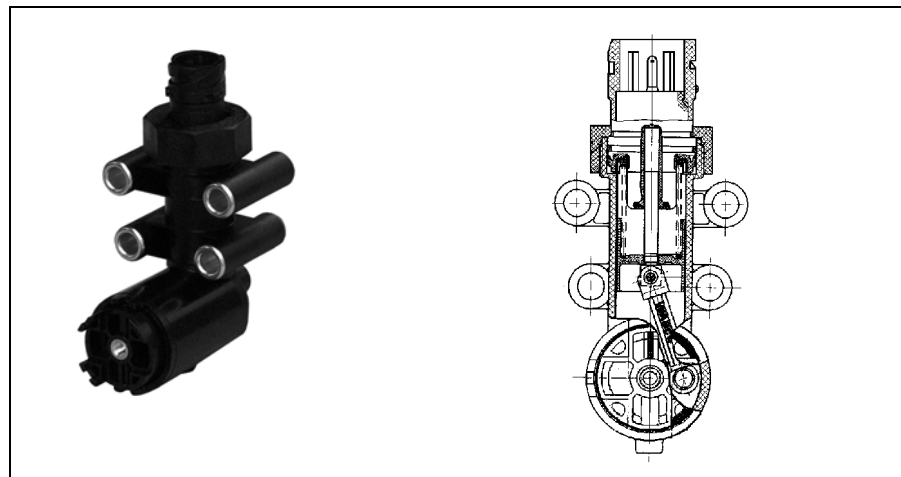

From the outside, the height sensor looks similar to WABCO's conventional levelling valve which means that it can often be fitted in the same location on the vehicle frame (the pattern of the two upper mounting bores is similar to that of the levelling valve).

The sensor housing contains a coil in which an armature is moved up and down. Via a connecting rod, the armature is connected to a cam on the

lever's shaft. The lever is connected to the vehicle axle.

As the distance between the superstructure and the axle changes, the lever is turned, causing the armature to move into or out of the coil. This changes the coil's inductance.

This inductance is being measured by the electronic control unit at short intervals and converted into a height signal.

Pressure sensor 441 040 00 . 0



The pressure sensor produces a voltage output which is proportional to the pressure present. The measuring range lies between 0 and 10 bar; a pressure of 16 bar must not be exceeded.

The signal voltage is sent to the ECU via a connecting plug. Furthermore, the sensor must receive a supply voltage from the ECU via a third conductor. The cable harness must be encased in a hose or similar material in such a way that the housing - which is otherwise waterproof - can "breathe".

Under no circumstances should the pressure sensor be connected to the connecting line between air suspension bellows and solenoid valve since this could result in wrong readings when pressurizing or venting is in progress.

If air suspension bellows with two threaded ports, as offered by renowned manufacturers of air suspension systems, cannot be used, a special connector must be fitted.

This connector can consist of a T-shaped pipe union, with a small pipe being welded into its pressure sensor connection protruding into the inside of the bellows, thereby sensing the "settled" bellows pressure.

A normal tee-piece can be used but only when a high raise/lowering-speed is not required. Two examples:

- One axle is sensed (drawbar-trailer with one lifting axle). The feed pipe from bellows to solenoid should be small (nominal size $\varnothing 6$) but the connection between bellows and sensor large.
- Two axles are sensed (3-axle-semitrailer with one lifting axle). Use $\varnothing 12$ pipe between the sensed bellows. Fit the pressure sensor in a tee piece next to one bellows. The line from the solenoid valve should be $\varnothing 9$ entering the system at the other bellows.